

NITROGEN-PAC M SERIES

**NITROGEN RECEIVER ASSEMBLY
 MODEL NR-30**

Description

The UNITED Fire Systems Model NR-30 is a 30 gallon capacity vertical steel tank for receiving and storing nitrogen from a NITROGEN-PAC M Series sprinkler corrosion inhibiting system nitrogen generator module. The receiver assembly is free-standing, with integral mounting feet, and is intended to be fastened to the surface upon which it rests. The assembly is equipped with a pressure gage and safety relief valve.

Specifications

- Capacity = 30 Gallons
- Weight = 79 lbs.
- Manufactured To = ASME Section VIII Division I
- Maximum Pressure = 200 PSIG
- Pressure Gage Scale = 0-200 PSIG
- Safety Relief Valve Setting = 175 PSIG

Attachment Fittings

- Inlet = 1/2" NPT
- Outlet = 1/2" NPT
- Drain = 1/2" NPT

Ordering Information

- Model NR-30

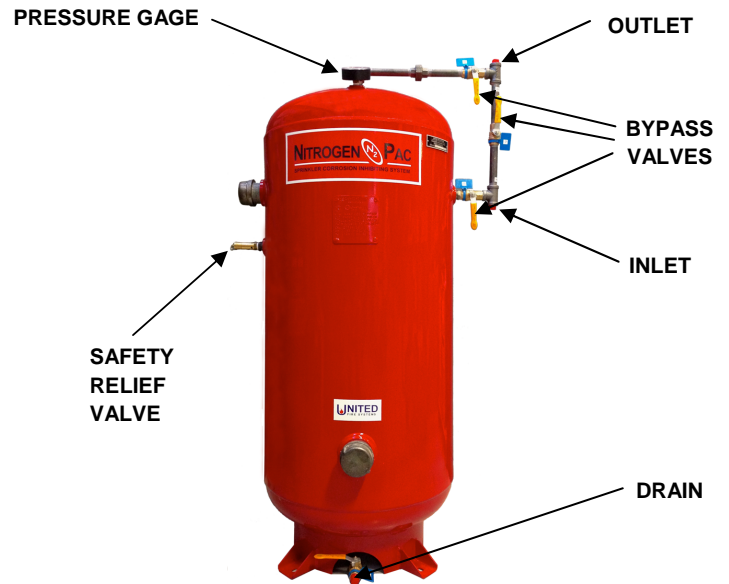

Dimensions	
Diameter	16"
L	38"
BC (Bolt Circle)	18.75"

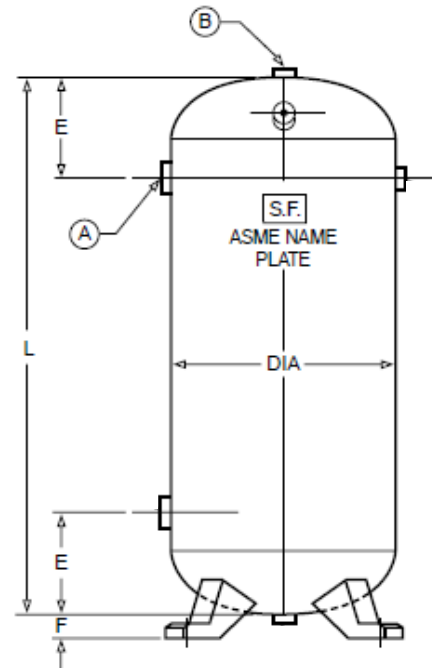
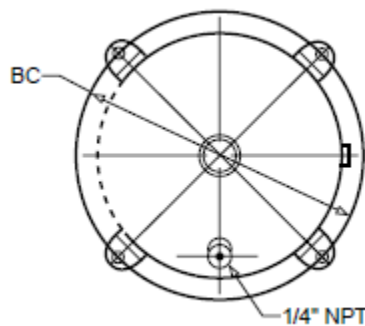

UNITED FIRE SYSTEMS

Division of United Fire Protection Corporation
 1 MARK ROAD

KENILWORTH, NJ 07033 USA

PHONE: 908-688-0300 FAX: 908-688-0218

www.unitedfiresystems.net

This literature is provided for informational purposes only. United Fire Protection Corporation assumes no responsibility for the product's suitability for a particular application. The product must be properly applied to perform as intended.