



with Notifier NFS2-640 Releasing Control Panel

# INSTALLATION, OPERATION, AND MAINTENANCE MANUAL

Serial Number \_\_\_\_\_

Date of Installation \_\_\_\_\_ Date of Commissioning \_\_\_\_\_



APPROVED

**UNITED Fire Protection Corporation**

1 Mark Road  
Kenilworth, NJ USA 07033  
908-688-0300  
[www.unitedfireprotection.com](http://www.unitedfireprotection.com)

Manual Part Number 10-500001-00B  
Version 1.1  
July 2011

## INDEX

Section	Description	Page
	Index	i
	List of Figures	ii
	List Of Tables	iii
	Hazard Identification	iv
	Foreword	v
1	General	
1.1	Introduction	2
1.2	Features	2
1.3	Functional Description	5
1.4	Configurations	7
1.5	Options	7
1.6	Approvals	7
1.7	Applicable Standards	7
1.8	Applicable Manuals	7
1.9	FM Approved Assemblies	13
1.10	Installation	
1.10.1	Location	15
1.10.2	Unpacking, Placement, and Leveling	15
1.10.3	Serial Number	17
1.10.4	External Attachments	17
1.10.5	Prior To Placing In Service	23
1.10.6	Placing In Service	23
1.11	Operation	
1.11.1	Automatic	23
1.11.2	Manual	23
1.11.3	Restoring To Service	24
1.12	Inspection, Testing, and Maintenance	24
2	Victaulic Manual I-769P – Firelock NXT Preaction Valve	
3	General Air Products Manual OILLESSINST – Compressor	
4.1	Notifier Manual 52741 – NFS2-640 Control Panel Installation	
4.2	Notifier Manual 52743 – NFS2-640 Control Panel Operation	
4.3	Notifier Manual 52742 – NFS2-640 Control Panel Programming	

PREACTION-PAC  
with NOTIFIER NFS2-640 RELEASING CONTROL PANEL  
INSTALLATION, OPERATION, AND MAINTENANCE MANUAL  
P/N 10-500001-00B  
VERSION 1.1 – JULY 2011

## LIST OF FIGURES

Figure No.	Description	Page
1	Illustration - PREACTION-PAC Shown With Enclosure Doors Closed	1
2	Illustration - PREACTION-PAC Shown With Enclosure Doors Open	3
3	Diagram - Functional Description	4
4	Diagram	15
5	Diagram - Location of Pallet Bolts and Leveling Feet	16
6	Diagram - Piping Attachment Details	18
7	Diagram - Terminal Strip Wiring Detail	20

PREACTION-PAC  
with NOTIFIER NFS2-640 RELEASING CONTROL PANEL  
INSTALLATION, OPERATION, AND MAINTENANCE MANUAL  
P/N 10-500001-00B  
VERSION 1.1 – JULY 2011

## LIST OF TABLES

Table No.	Description	Page
1.8.1	Items Applicable and Not Applicable in Section 2 – Victaulic Manual I769P – Firelock NXT Preaction Valve	8
1.8.2	Items Applicable and Not Applicable in Section 3 – General Air Products Manual OILLESSINST - Compressor	9
1.8.3.1	Items Applicable and Not Applicable in Section 4 – Notifier Manual 52741 – NFS2-640 Control Panel Installation	10
1.8.3.2	Items Applicable and Not Applicable in Section 4 – Notifier Manual 52743 – NFS2-640 Control Panel Operations	11
1.8.3.3	Items Applicable and Not Applicable in Section 4 – Notifier Manual 52742 – NFS2-640 Control Panel Programming	12
1.9.1	FM Approved Assemblies with Notifier NFS2-640 Control Panel	14



## HAZARD IDENTIFICATION

Carefully read, understand, and follow instructions identified by these symbols.



The use of the word “DANGER” identifies an immediate hazard with a likelihood of death or serious personal injury if instructions, including recommended precautions, are not followed.



The use of the word “WARNING” identifies the presence of hazards or unsafe practices that could result in death, personal injury, or serious property damage if instructions, including recommended precautions, are not followed.



The use of the word “CAUTION” identifies possible hazards or unsafe practices that could result in personal injury or property damage if instructions, including recommended precautions, are not followed.



The use of the word “IMPORTANT” identifies special instructions, not related to hazards, that should be followed.

## FOREWORD

This manual is written for those who install, operate and maintain United Fire Protection PREACTION-PAC sprinkler valve assemblies. The manual contains installation, operation, and maintenance information for these assemblies.



### IMPORTANT

United Fire Protection assumes no responsibility for the installation, operation, or maintenance of any systems other than those addressed in this manual. The data contained in this manual is for information purposes only. United Fire Protection believes this data to be accurate at the time of publication, but the data is published and presented without any guarantee or warranty whatsoever. United Fire Protection disclaims any liability for any use that may be made of the data and information contained in this manual by any and all parties.



### IMPORTANT

The United Fire Protection PREACTION-PAC sprinkler valve assembly is a vital part of the fire protection of any facility where these units are installed. Life safety and property protection depends on continuing proper operation of the assembly. The owner of the PREACTION-PAC is responsible for the condition of the assembly and its continued proper operation. United Fire Protection strongly recommends that all owners of PREACTION-PACs engage the services of qualified, trained fire protection professionals to design the system containing the assembly, and to install and maintain the assembly.

United Fire Protection PREACTION-PAC sprinkler valve assemblies are to be installed and maintained by qualified, trained personnel in accordance with:

- This Installation, Operation, and Maintenance Manual P/N 10-500001-00B.
- National Fire Protection Association No. 13, “Standard for the Installation of Sprinkler Systems.”
- National Fire Protection Association No. 25, “Standard for the Inspection, Testing, and Maintenance of Water-Based Fire Protection Systems.”
- National Fire Protection Association No. 70, “National Electrical Code®”.
- National Fire Protection Association No. 72, “National Fire Alarm Code®”.

Any questions on the information in this manual should be addressed to:

United Fire Protection Corporation  
1 Mark Road  
Kenilworth, NJ USA 07033  
908-688-0300  
[www.unitedfireprotection.com](http://www.unitedfireprotection.com)

PREACTION-PAC  
with NOTIFIER NFS2-640 RELEASING CONTROL PANEL  
INSTALLATION, OPERATION, AND MAINTENANCE MANUAL  
P/N 10-500001-00B  
VERSION 1.1 – JULY 2011

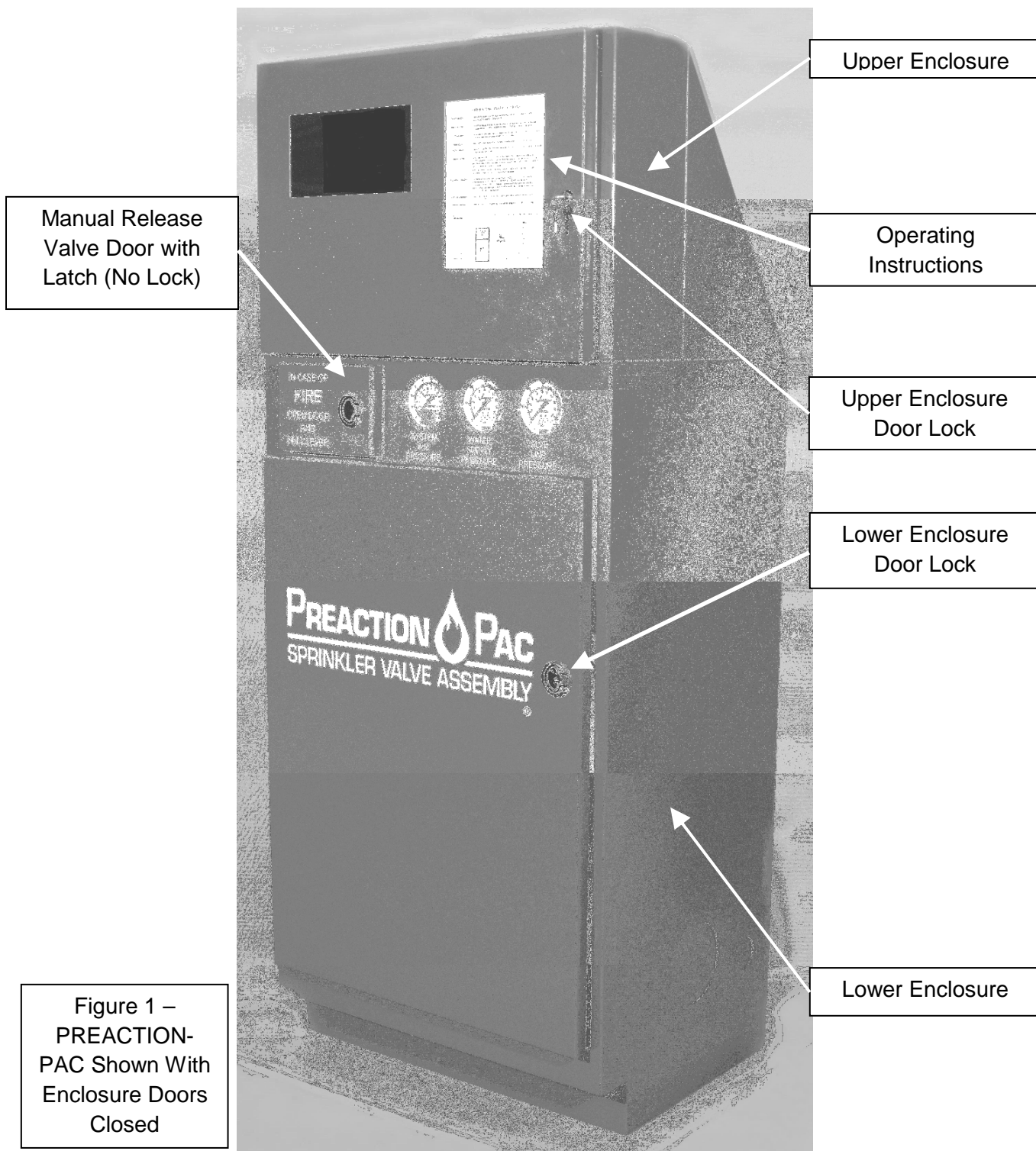


Figure 1 –  
PREACTION-  
PAC Shown With  
Enclosure Doors  
Closed

## 1. GENERAL

- 1.1. Introduction.** The United Fire Protection PREACTION-PAC is a fully assembled and factory tested pre-action fire suppression system, including pre-action valve, trim, and control panel providing one complete zone of pre-action water sprinkler fire protection. All components are contained in two steel enclosures assembled one above the other. The system pressure gages and the required manual release handle are mounted on the front of the lower enclosure. The system detection and control panel is mounted behind a door in the upper enclosure with a clear polycarbonate window allowing visual access to the system indicators. Lockable latches on both doors permit authorized access to all system components. Both enclosures are finished in powder-coat red paint. Gasketing provides sealing of the enclosure doors. Knockouts permit easy attachment of external electrical conduits.
- 1.1.1. Pre-Action-Valve.** The pre-action valve installed in the PREACTION-PAC is a low-differential, latched clapper valve that uses a unique direct-acting diaphragm to separate the system water supply from the system piping. The positive latching system uses the supply water pressure to hold the clapper shut. When the water pressure in the diaphragm chamber is released, the latch retracts from the clapper and the valve actuates. The low differential and unique latch and actuator design of the valve allows the valve to be self-resetting.
- 1.1.2. Piping.** Water inlet pipe connections are located on the lower left and lower right sides and the upper right corner of the lower enclosure. (NOTE: Assemblies equipped with 1/2HP compressors do not have upper right corner inlet connection.) The unused inlets are left plugged. Grooved pipe is used for the inlet connection. The water outlet pipe connection is located at the top center of the lower enclosure, behind the upper enclosure. The drain connection is accessible within the lower enclosure, and knockouts are provided allowing exit of the drain from either side. All pipe connections are done in the lower enclosure.
- 1.1.3. Control Panel.** A Notifier NFS2-640 addressable releasing control panel is factory-installed in the upper enclosure. Programming for a basic pre-action system is factory programmed and tested. Additional programming may be necessary after installation to suit field conditions. This manual provides complete instructions for additional programming. All necessary internal wiring connections are factory-installed and tested.
- 1.1.4. Wiring.** All wiring from the integral control panel to the valve solenoid and all switches is factory installed and tested. Wiring for compressor power and control is also factory installed and tested. All field wiring for control panel power, compressor power, detection circuits, notification appliance circuits, and circuits requiring contact closure is connected to terminal strips in the upper enclosure. No access to the lower enclosure is necessary to complete the wiring installation.
- 1.1.5. Compressor.** The compressor for air pressurization of the pre-action sprinkler piping is pre-installed, wired and adjusted. Three sizes of compressor are available, depending on the volume of installed piping to be pressurized. The compressor is mounted using molded rubber mounts and bushings to minimize noise and vibration during motor operation. A compressor disconnect switch is located in the upper enclosure.

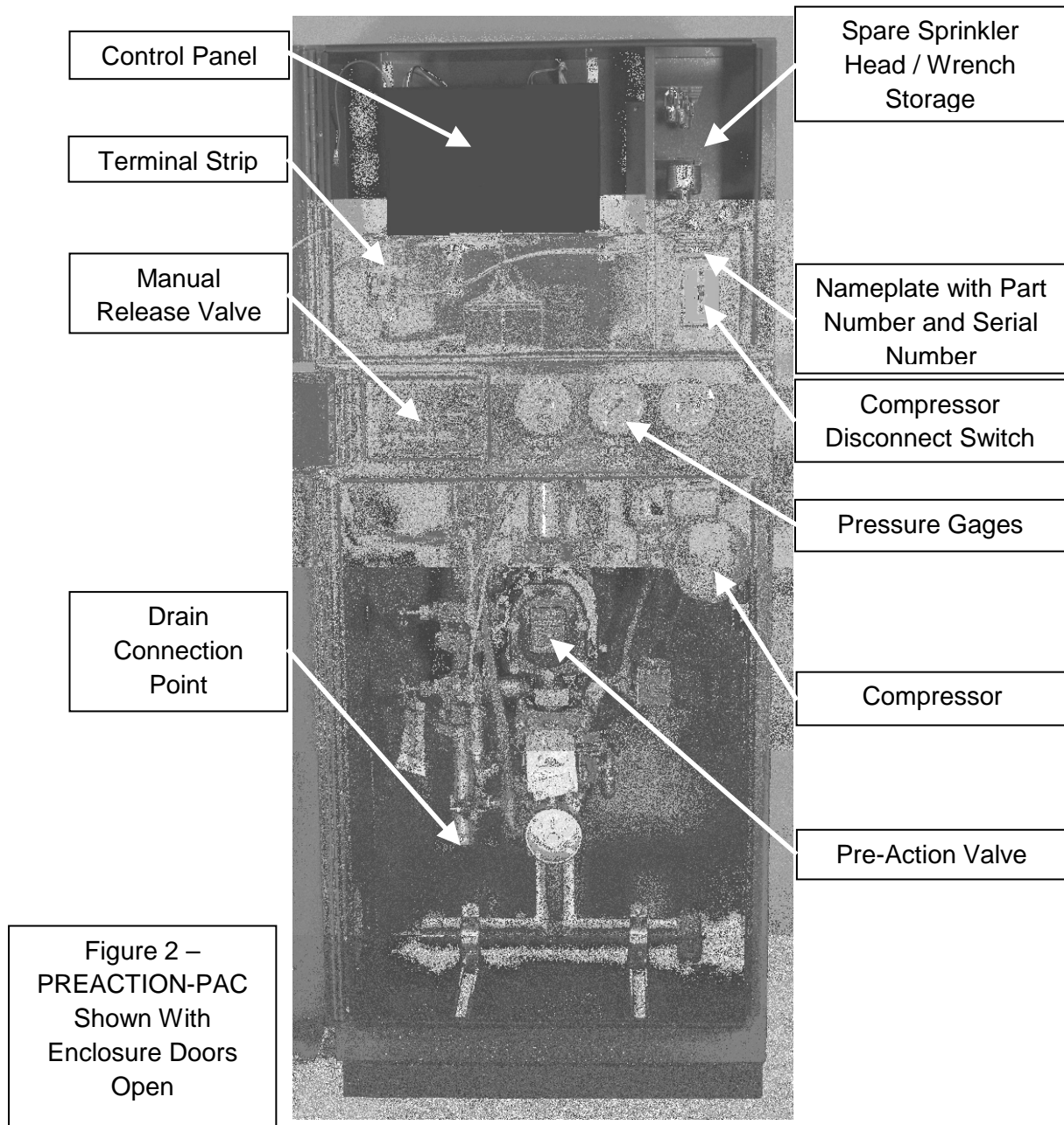
### 1.2. Features

- 1.2.1. Attractive and rugged metal enclosure.** The entire enclosure is manufactured from steel with continuous welded seams. The lower enclosure is 12 gage, while the upper enclosure is 14 gage. Both enclosures are coated with red powder-coat paint inside and out. Continuous piano-style hinges attach the doors to the enclosures.
- 1.2.2. Easy-to-see gages on front of enclosure.** Three pressure gages are mounted on the front of the lower enclosure, and are visible at all times. These gages monitor the air pressure in the system piping, the water supply pressure up to the pre-action valve, and the water pressure keeping the valve clapper piston closed.
- 1.2.3. Easy access to manual release valve.** The emergency manual release ball valve is located behind a small unlocked door on the front of the lower enclosure. Operation of this ball valve opens the pre-action valve, filling the system piping with water. No power is necessary to accomplish this

PREACTION-PAC  
with NOTIFIER NFS2-640 RELEASING CONTROL PANEL  
INSTALLATION, OPERATION, AND MAINTENANCE MANUAL  
P/N 10-500001-00B  
VERSION 1.1 – JULY 2011

operation. The key for the lower enclosure main door does not have to be available to accomplish this operation.

- 1.2.4. Lower and upper water inlet connections. The water inlet piping may attach to the lower enclosure either near the bottom on either side, or to a pre-piped upper inlet at the top of the lower enclosure. (NOTE: Assemblies equipped with 1/2HP compressors do not have upper inlet connection.)
- 1.2.5. Easy-to-follow instructions on enclosure front. System instructions, mounted behind clear plastic, are located on the front of the upper enclosure.
- 1.2.6. Space for required spare sprinkler heads and wrench. As required by NFPA 13, a built-in storage location for spare sprinkler heads and a sprinkler wrench is behind the door of the upper enclosure.
- 1.2.7. Separate mechanical and electrical enclosures. This allows mechanical and electrical trades to keep their work areas separate.



PREACTION-PAC  
 with NOTIFIER NFS2-640 RELEASING CONTROL PANEL  
 INSTALLATION, OPERATION, AND MAINTENANCE MANUAL  
 P/N 10-500001-00B  
 VERSION 1.1 – JULY 2011

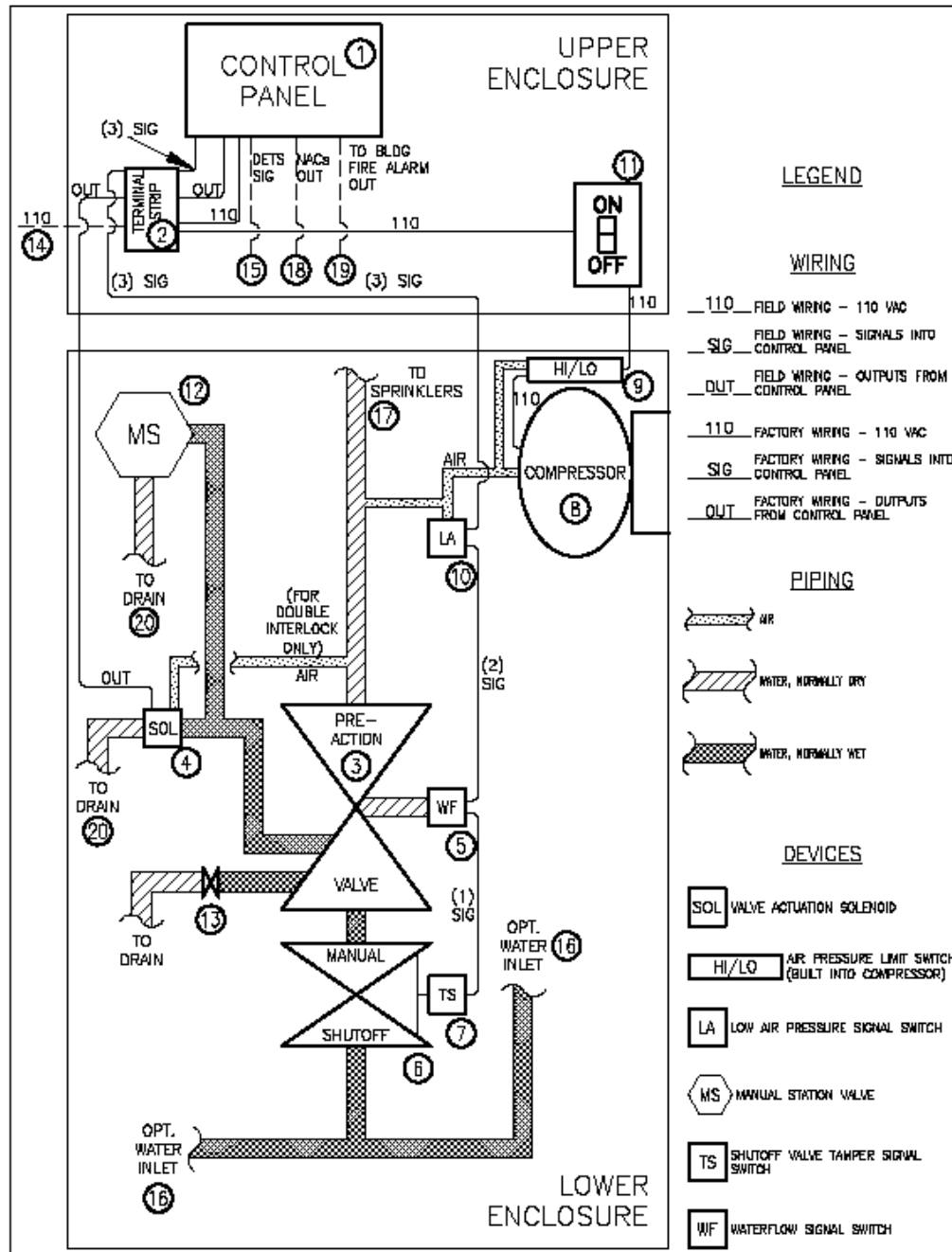


Figure 3 – Diagram - Functional Description

**1.3. Functional Description.** Refer to Figure 3 on page 4.

- 1.3.1. Control panel (1).** The control panel receives signals from fire detectors located in the protected space, as well as signals from various switches within the assembly. The panel processes the input signals per a pre-determined sequence of operation, and operates outputs for external audible / visual devices and building fire alarm signaling, as well as the signal to open the pre-action valve within the assembly. Refer to the control panel instruction manuals in Section 4 for details on the panel and the sequence of operation.
- 1.3.2. Terminal strip (2).** The terminal strip provides a convenient point for landing some of the required field wiring, and also serves as the interface point between the control panel (1) and the various connections in the lower enclosure.
- 1.3.3. Pre-action valve (3).** The pre-action valve is the heart of the assembly. The valve holds back the sprinkler water until the control panel (1) reacts to the signal from the fire detectors and sends a signal to the valve actuation solenoid (4). In single-interlock assemblies, actuation of the valve actuation solenoid (4) sends water into the sprinkler pipe. In double-interlock assemblies, fusing of a sprinkler head from heat is required, along with valve actuation solenoid (4) actuation, to send water into the sprinkler pipe. Refer to Manual I-769P in Section 2 for more detailed information on the pre-action valve.
- 1.3.4. Valve actuation solenoid (4).** The valve actuation solenoid receives the signal from the control panel (1), and actuates the pre-action valve (3). The solenoid is the Victaulic Series 753-E, and is rated at 24VDC, 0.364 amps, 8.7 watts, 66 ohms. The solenoid is FM Approved under Group I (as in India). Refer to Manual I-769P in Section 2 for more detailed information.
- 1.3.5. Waterflow signal switch (5).** The waterflow signal switch responds to waterflow in the pipe downstream of the pre-action valve (3). The switch contains Quantity 2, SPDT switches, rated at 10A-125/250VAC, 1/2HP, 2.5A-6/12/24VDC. Contacts transfer when waterflow begins after pre-action valve opens. Contacts automatically restore when waterflow ceases. One contact is factory-wired to send a signal to the control panel (1). Refer to the control panel instruction manual in Section 4 for details on the response of the panel to the waterflow signal switch.
- 1.3.6. Manual shutoff valve (6).** The manual shutoff valve is used to shut off the flow of water after actuation of the pre-action valve (3). The normal position of this valve when the system is in service is open. Refer to Manual I-769P in Section 2 for more detailed information on the use of this valve.
- 1.3.7. Shutoff valve tamper signal switch (7).** The shutoff valve tamper signal switch sends a supervisory signal to the control panel (1) when the manual shutoff valve (6) is closed. The switch contains Quantity 2, SPDT switches, rated at 10A-125/250VAC, 0.5A-125VDC. Contacts transfer when valve begins to close. Contacts restore when valve is fully open. One contact is factory-wired to send a signal to the control panel (1). Refer to the control panel instruction manual in Section 4 for details on the response of the panel to the shutoff valve tamper signal switch.
- 1.3.8. Compressor (8).** The compressor supplies supervisory air pressure to fill the sprinkler pipe downstream of the pre-action valve (3). The sprinkler pipe is pressurized to 13 PSIG minimum and 18 PSIG maximum by the compressor (8). Loss of this pressure, from damage to the pipe or a sprinkler head, results in a supervisory signal at the control panel (1).
- 1.3.9. High / low air pressure limit switch (9).** The high / low air pressure limit switch is built in to the compressor (8). When pressure in the pipe falls below 13 PSIG, the switch turns the compressor (8) on. When pressure in the pipe rises to 18 PSIG, the switch turns the compressor (8) off.
- 1.3.10. Low air pressure signal switch (10).** The low air pressure signal switch sends the supervisory signal for low air pressure to the control panel (1). The switch contains Quantity 2, SPDT switches, rated at 10A-125/250VAC, 1/2HP, 2.5A-6/12/24VDC. Contacts transfer when pressure in the piping falls below 13PSIG. Contacts automatically restore when pressure rises above 13PSIG. One contact is factory-wired to send a signal to the control panel (1). Refer to the control panel instruction manual in Section 4 for details on the response of the panel to the low air pressure signal switch.
- 1.3.11. Compressor disconnect switch (11).** The compressor disconnect switch is used to manually interrupt the 110VAC power to the compressor motor, during inspection, maintenance, and

resetting of the assembly. Only trained personnel should use this switch. The normal position of this switch when the system is in service is ON.

- 1.3.12. Manual station valve (12).** The manual station valve is located behind a separate door on the front of the lower enclosure. No key is needed to open this door. To manually open the pre-action valve (3), open the door and pull the lever on the manual station valve forward. The pre-action valve (3) will open, and the sprinkler pipe will fill with water. No power is needed to manually open the pre-action valve (3) in this manner.



**IMPORTANT**

Fusing of a sprinkler head by heat is necessary for water to be discharged onto a fire, even after operation of the manual station valve.

- 1.3.13. Drain valve (13).** The drain valve is used to drain the sprinkler pipe after actuation of the pre-action valve (3). This valve is used only during inspection, maintenance, and resetting of the assembly. Only trained personnel should use this valve. Refer to Manual I-769P in Section 2 for more detailed information on this valve. The normal position of this valve is closed.

- 1.3.14. Input connection for 110 VAC power (14).** 110VAC is required to power the assembly. This power shall come from a source in compliance with all applicable codes and standards. Internal wiring (factory assembled) takes this power to the control panel (1) and the compressor (8). If local codes require individual 110VAC power sources for the control panel (1) and the compressor (8), jumpers may be removed from the terminal strip (2) permitting this. Refer to Section 1.10 for additional information on this connection.

- 1.3.15. Input connection for automatic fire detectors (15).** Automatic fire detectors are required to provide the signal for opening the pre-action valve (3). These detectors are field-connected to this connection. See Section 1.10, and refer to the control panel instruction manuals in Sections 4.1, 4.2, and 4.3 for details on these detectors and this connection.



**IMPORTANT**

Fusing of a sprinkler head by heat is necessary for water to be discharged onto a fire, even after operation of automatic fire detectors.

- 1.3.16. Water inlet connection (16).** The sprinkler water supply is field-connected to this connection. One of three optional water inlet connections may be chosen. The first is at the upper right corner of the lower enclosure. Use this connection if it is desired to bring the pipe to the assembly from above. (NOTE: Assemblies equipped with 1/2HP compressors do not have upper right corner inlet connection.) If it is desired to bring the pipe to the assembly from a location close to the floor, the connection may be made on the lower left of the assembly, or by disconnecting the top inlet piping, the connection may be made on the lower right of the assembly. Refer to Section 1.10 and Section 2 – Victaulic manual I-769P for more detailed information on this connection.

- 1.3.17. Outlet connection to fire sprinklers (17).** The outlet connection from the assembly to the fire sprinklers is field-connected to this connection. The connection is located in the top center of the lower enclosure, behind the upper enclosure. Refer to Section 1.10 and Section 2 – Victaulic manual I-769P for more detailed information on this connection.



- 1.3.18. Notification appliance output connection (18).** Notification appliances are required by code to alert occupants that a fire has been detected. These appliances are field-connected to this connection. Refer to the control panel instruction manuals in Section 4 for details on this connection.
- 1.3.19. Output connection to building fire alarm system (19).** Most codes require a fire protection sub-system to signal the building fire alarm system. This signal is field-connected to this connection. Refer to the control panel instruction manuals in Section 4 for details on this connection.
- 1.3.20. Drain connection (20).** Drain water from the assembly must be piped away to a drain. The drain piping may be connected to the assembly on the left or the right side. Refer to Section 1.10 and Section 2 – Victaulic manual I-769P for more detailed information on this connection.
- 1.4. Configurations.** United Fire Protection PREACTION-PAC sprinkler valve assemblies are available in the following configurations:
- 1.4.1. Valve sizes:** 1-1/2" through 4".
- 1.4.2. Valve types:** Single-interlock and double-interlock available in all valve sizes.
- 1.4.3. Compressor sizes:**
- 1.4.3.1.** For 1-1/2" and 2" valves: 1/6HP compressor only.
- 1.4.3.2.** For 2-1/2" valves: 1/6HP and 1/3HP compressors available.
- 1.4.3.3.** For 3" and 4" valves: 1/6HP, 1/3HP, and 1/2HP compressors available.
- 1.4.3.4.** Compressors are capable of pressurizing piping systems up to the following limits:
- 1.4.3.4.1.** 1/6HP compressor: maximum system capacity is 290 gallons.
- 1.4.3.4.2.** 1/3HP compressor: maximum system capacity is 475 gallons.
- 1.4.3.4.3.** 1/2HP compressor: maximum system capacity is 780 gallons.
- 1.4.4. Control panel:** A Notifier NFS2-640 addressable detection control panel is factory-installed in the upper enclosure.
- 1.5. Options.** None at this time.
- 1.6. Approvals.** United Fire Protection PREACTION-PAC sprinkler valve assemblies, as listed in this Manual, are Approved by FM Approvals under the heading "Automatic Water Control Valves." See pages 13 and 14 for Approved assemblies. NOTE: Although most PREACTION-PAC assemblies are FM Approved, custom-built units are supplied from time to time upon request. Various components within these custom assemblies maintain their individual approvals, but these custom assemblies are not FM Approved as a unit.
- 1.7. Applicable Standards.** United Fire Protection PREACTION-PAC sprinkler valve assemblies are to be installed and maintained by qualified, trained personnel in accordance with:
- 1.7.1.** National Fire Protection Association No. 13, "Standard for the Installation of Sprinkler Systems."
- 1.7.2.** National Fire Protection Association No. 25, "Standard for the Inspection, Testing, and Maintenance of Water-Based Fire Protection Systems."
- 1.7.3.** National Fire Protection Association No. 70, "National Electrical Code®".
- 1.7.4.** National Fire Protection Association No. 72, "National Fire Alarm Code®."
- 1.8. Applicable Manuals.** Manuals supplied by the manufacturers of components used in United Fire Protection PREACTION-PAC assemblies are included with this manual. In some cases, these manuals contain references that are **NOT APPLICABLE** to PREACTION-PAC assemblies. The following tables detail these NOT APPLICABLE items. Care should be taken to be clear on what is applicable and what is not when referring to these manuals for installation, operation, inspection, and maintenance instructions.

PREACTION-PAC  
with NOTIFIER NFS2-640 RELEASING CONTROL PANEL  
INSTALLATION, OPERATION, AND MAINTENANCE MANUAL  
P/N 10-500001-00B  
VERSION 1.1 – JULY 2011

Table 1.8.1 – Items Applicable and Not Applicable in Section 2 – Victaulic Manual  
I769P – Firelock NXT Preaction Valve

Page No.	X Indicates Page IS Applicable	X Indicates Page IS NOT Applicable	Notes
Title	X		
Blank		X	
1 - 2	X		
3	X		Applicable valve sizes are 1-1/2" through 4".
4 - 6		X	
7	X		Item 10 – Series 760 Water Motor Alarm is NOT applicable.
8	X		
9	X		Series 776 Low Pressure Actuator is applicable to Double Interlock only.
10		X	
11	X		Series 757 Regulated AMTA is NOT applicable.
12	X		Series 757P Regulated AMTA is NOT applicable.
13	X		It is NOT necessary to remove foam spacer from valve – operation performed at UFP factory.
14	X		Compression fittings and tubes installed at UFP factory.
15	X		Series 746-LPA Dry Accelerator NOT installed.
16 - 17	X		1. Series 776 Low Pressure Actuator is applicable to Double Interlock only. 2. Step 11 – Ball valves on AMTA are NOT applicable.
18 - 19	X		Series 746-LPA Dry Accelerator is NOT applicable.
20 - 21	X		AMTA and Dry Accelerator ball valves are NOT applicable.
22	X		
23	X		AMTA and Dry Accelerator ball valves are NOT applicable.
24	X		
25	X		Series 746-LPA Dry Accelerator is NOT applicable.
26	X		AMTA ball valves are NOT applicable.
27 - 28	X		AMTA and Dry Accelerator ball valves are NOT applicable.
29 - 33	X		
34	X		AMTA ball valves are NOT applicable.
35 - 37	X		
38	X		Applicable valve sizes are 1-1/2" through 4".
39	X		
40	X		Applicable valve sizes are 1-1/2" through 4".
41	X		
42	X		Series 776 Low Pressure Actuator is applicable to Double Interlock only.
43	X		1. Series 776 Low Pressure Actuator is applicable to Double Interlock only. 2. Series 746-LPA Dry Accelerator is NOT applicable.
44	X		AMTA is not applicable.

PREACTION-PAC  
with NOTIFIER NFS2-640 RELEASING CONTROL PANEL  
INSTALLATION, OPERATION, AND MAINTENANCE MANUAL  
P/N 10-500001-00B  
VERSION 1.1 – JULY 2011

Table 1.8.2 – Items Applicable and Not Applicable in Section 3 – General Air Products  
Manual OILLESSINST – Compressor

Page No.	X Indicates Page IS Applicable	X Indicates Page IS NOT Applicable	Notes
1	X		<ol style="list-style-type: none"> <li>1. For assistance, please contact United Fire Protection.</li> <li>2. The sections on “Receiving” and “Mounting” are not applicable, since the compressor has been unpacked, mounted in the assembly, and tested by UFP.</li> </ol>
2	X		<ol style="list-style-type: none"> <li>1. The AMD-1 is not applicable.</li> <li>2. Applicable units are OL11016, OL21533, and OL33550. All other units are not applicable.</li> </ol>
3	X		<ol style="list-style-type: none"> <li>1. Applicable pressure switch setting is 13 PSIG cut-in and 18 PSIG cut-out.</li> <li>2. Compressors used by UFP are single-phase models. Three-phase information is not applicable.</li> <li>3. Warranty is supplied by United Fire Protection Corporation. Warranty information on this page is not applicable.</li> </ol>
4	X		For excessive noise in operation, contact United Fire Protection. General Air Products contact note is not applicable.
5 - 6		X	
7	X		Figure 1 is applicable. Figure 2 is not applicable.
8		X	

PREACTION-PAC  
with NOTIFIER NFS2-640 RELEASING CONTROL PANEL  
INSTALLATION, OPERATION, AND MAINTENANCE MANUAL  
P/N 10-500001-00B  
VERSION 1.1 – JULY 2011

Table 1.8.3.1 – Items Applicable and Not Applicable in Section 4.1 – Notifier Manual  
52741 – NFS2-640 Control Panel Installation

Page No.	X Indicates Page IS Applicable	X Indicates Page IS NOT Applicable	Notes
Cover	X		
2-11	X		
12	X		Panel is fitted with KDM-R2 keypad / display by UFP.
13-15	X		
16		X	Panel is contained within PREACTION-PAC upper enclosure – no need to install a backbox.
17-18	X		
19	X		
20-24	X		Panel is contained within PREACTION-PAC upper enclosure – no need to install a backbox.
25-26		X	
27	X		
28-29		X	
30-33	X		
34		X	Connect AC power to terminal strip in upper enclosure per Section 1.10.
35-38	X		Applicable as required for system options installed in field.
39	X		Follow the guidelines on this page for wire routing, keeping in mind that the panel is installed in the PREACTION-PAC upper enclosure, not the OEM enclosure.
40-44	X		Applicable as required for system options installed in field.
45			Inputs from supervisory switches wired by UFP.
46-49			Applicable as required for system options installed in field.
50	X		STS-1 Security Tamper Switch not applicable.
51-54	X		Solenoid output for pre-action valve wired by UFP.
55		X	
56-58	X		
59-60	X		
61-66	X		If calculated battery size exceeds 26 A-H, use separate battery cabinet.
67-70	X		
71-74	X		
75		X	Warranty is supplied by United Fire Protection Corporation. Warranty information on this page is not applicable.

PREACTION-PAC  
with NOTIFIER NFS2-640 RELEASING CONTROL PANEL  
INSTALLATION, OPERATION, AND MAINTENANCE MANUAL  
P/N 10-500001-00B  
VERSION 1.1 – JULY 2011

Table 1.8.3.2 – Items Applicable and Not Applicable in Section 4.2 – Notifier Manual  
52743 – NFS2-640 Control Panel Operations

Page No.	X Indicates Page IS Applicable	X Indicates Page IS NOT Applicable	Notes
Cover	X		
2-8	X		
9-12	X		
13-18	X		
19-34	X		
35-48	X		
49-58	X		Cross-zoning of pre-action systems not permitted in NYC.
59-60	X		
61-68	X		
69-74	X		
75		X	Warranty is supplied by United Fire Protection Corporation. Warranty information on this page is not applicable.

PREACTION-PAC  
with NOTIFIER NFS2-640 RELEASING CONTROL PANEL  
INSTALLATION, OPERATION, AND MAINTENANCE MANUAL  
P/N 10-500001-00B  
VERSION 1.1 – JULY 2011

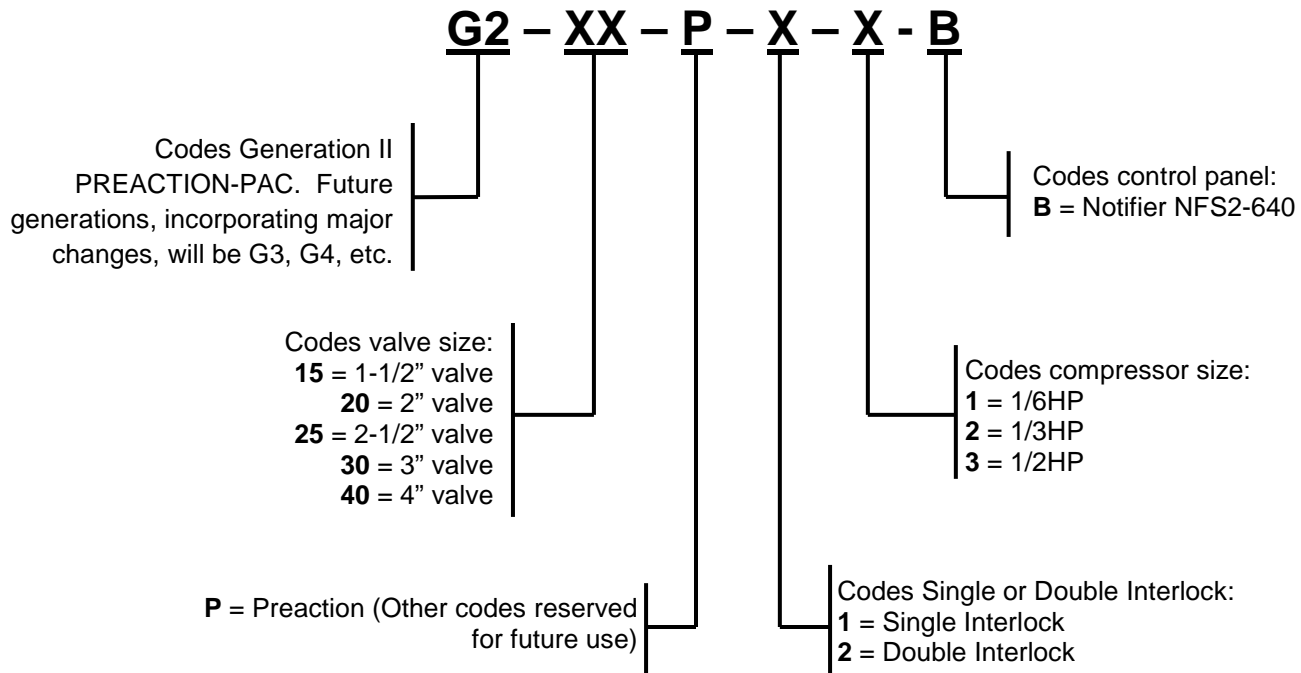
Table 1.8.3.3 – Items Applicable and Not Applicable in Section 4.3 – Notifier Manual  
52742 – NFS2-640 Control Panel Programming

Page No.	X Indicates Page IS Applicable	X Indicates Page IS NOT Applicable	Notes
Cover	X		
2-8	X		
9-13	X		
14-45	X		
46-53	X		
54-86	X		The control panel is factory-programmed by UFP with a basic pre-action system program. When changes are necessary to suit field conditions, follow the instructions on these pages. NOTE: Cross-zoning of pre-action systems not permitted in NYC.
87-89	X		
90-100	X		
101-104	X		
105-106	X		
107-112	X		
113-118	X		
119		X	Warranty is supplied by United Fire Protection Corporation. Warranty information on this page is not applicable.

PREACTION-PAC  
with NOTIFIER NFS2-640 RELEASING CONTROL PANEL  
INSTALLATION, OPERATION, AND MAINTENANCE MANUAL  
P/N 10-500001-00B  
VERSION 1.1 – JULY 2011

### 1.9 FM Approved Assemblies

Part Number Coding:



PREACTION-PAC assemblies with indicated part numbers are FM Approved. From time to time, custom-built units are supplied upon request. The components in these custom-built units retain their individual approvals, but these custom-built units are not FM Approved.

When the Preaction-Pac is installed where FM Global is an AHJ, follow the requirements of FM Approvals Class Numbers 1011, 1012, 1013 and FM Global Property Loss Prevention Data Sheet 5-40 dated 2007, especially:

- Alarm control panels for automatic release of preaction sprinkler systems are required to have 90 hours of secondary power followed by 10 minutes of release power and alarm operation.
- Include the installation of Class A (Style D or E) initiating device circuits. All FM Approved systems / installations must be configured as Class A for Deluge and Preaction Releasing Service.
- Do not include abort switches to abort the preaction sprinkler actuation function.

PREACTION-PAC  
with NOTIFIER NFS2-640 RELEASING CONTROL PANEL  
INSTALLATION, OPERATION, AND MAINTENANCE MANUAL  
P/N 10-500001-00B  
VERSION 1.1 – JULY 2011

Table 1.9.1 – Approved PREACTION-PAC Assemblies with Notifier NFS2-640 Control Panel

Part Number	Valve Size, in.	Valve Type	Compressor Size, HP	Control Panel
G215P11B	1-1/2"	Single Interlock	1/6	Notifier NFS2-640
G215P21B	1-1/2"	Double Interlock	1/6	Notifier NFS2-640
G220P11B	2"	Single Interlock	1/6	Notifier NFS2-640
G220P21B	2"	Double Interlock	1/6	Notifier NFS2-640
G225P11B	2-1/2"	Single Interlock	1/6	Notifier NFS2-640
G225P12B	2-1/2"	Single Interlock	1/3	Notifier NFS2-640
G225P21B	2-1/2"	Double Interlock	1/6	Notifier NFS2-640
G225P22B	2-1/2"	Double Interlock	1/3	Notifier NFS2-640
G230P11B	3"	Single Interlock	1/6	Notifier NFS2-640
G230P12B	3"	Single Interlock	1/3	Notifier NFS2-640
G230P13B	3"	Single Interlock	1/2	Notifier NFS2-640
G230P21B	3"	Double Interlock	1/6	Notifier NFS2-640
G230P22B	3"	Double Interlock	1/3	Notifier NFS2-640
G230P23B	3"	Double Interlock	1/2	Notifier NFS2-640
G240P11B	4"	Single Interlock	1/6	Notifier NFS2-640
G240P12B	4"	Single Interlock	1/3	Notifier NFS2-640
G240P13B	4"	Single Interlock	1/2	Notifier NFS2-640
G240P21B	4"	Double Interlock	1/6	Notifier NFS2-640
G240P22B	4"	Double Interlock	1/3	Notifier NFS2-640
G240P23B	4"	Double Interlock	1/2	Notifier NFS2-640



PREACTION-PAC  
with NOTIFIER NFS2-640 RELEASING CONTROL PANEL  
INSTALLATION, OPERATION, AND MAINTENANCE MANUAL  
P/N 10-500001-00B  
VERSION 1.1 – JULY 2011

**1.10. Installation.**

**1.10.1. Location.** Locate the PREACTION-PAC assembly as shown on the system shop drawings or design plans. The location should be dry, clean, and within the Approved temperature range of the assembly (+40 deg F to +110 deg F). Refer to Figure 4 for overall dimensions.

**1.10.2. Unpacking, Placement & Leveling.** Unpack the PREACTION-PAC as follows:

**1.10.2.1.** Remove the outer carton and any other packing material surrounding the assembly.

**1.10.2.2.** Open the lower enclosure door.

**1.10.2.3.** Use a flat-bladed or Phillips screwdriver to remove the (4) bolts holding the assembly to the pallet. See Figure 5.

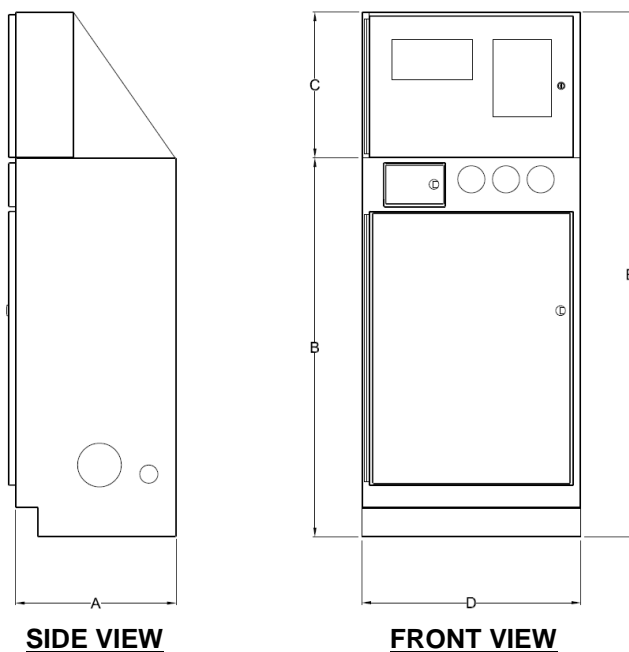
**1.10.2.4.** Close the lower enclosure door. Remove the unit from the pallet, and place in the intended installation location.

**1.10.2.5.** Level the unit:

**1.10.2.5.1.** Open the lower enclosure door.

**1.10.2.5.2.** Using a flat-bladed screwdriver, adjust the (4) leveling feet from inside the enclosure until all feet are firmly in contact with the floor. See Figure 5.

**1.10.2.5.3.** Using a spirit level, adjust the leveling feet until the assembly is level both front-to-back and side-to-side.



Dimension	Assemblies with 1-1/2" thru 3" Pre-Action Valves	Assemblies with 4" Pre-Action Valves
A	22.00	24.00
B	52.00	52.00
C	20.00	20.00
D	30.00	30.00
E	72.00	72.00

NOTE: All units are in inches.

Figure 4 – Diagram - Overall Dimensions

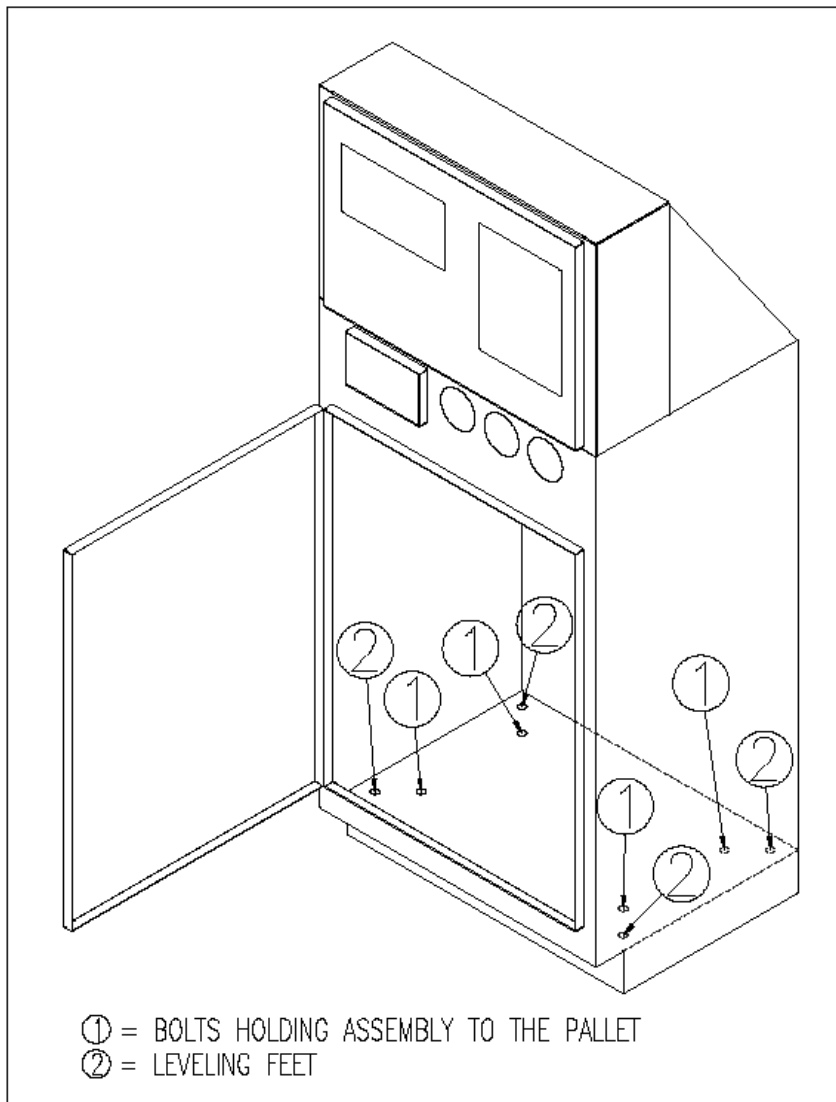
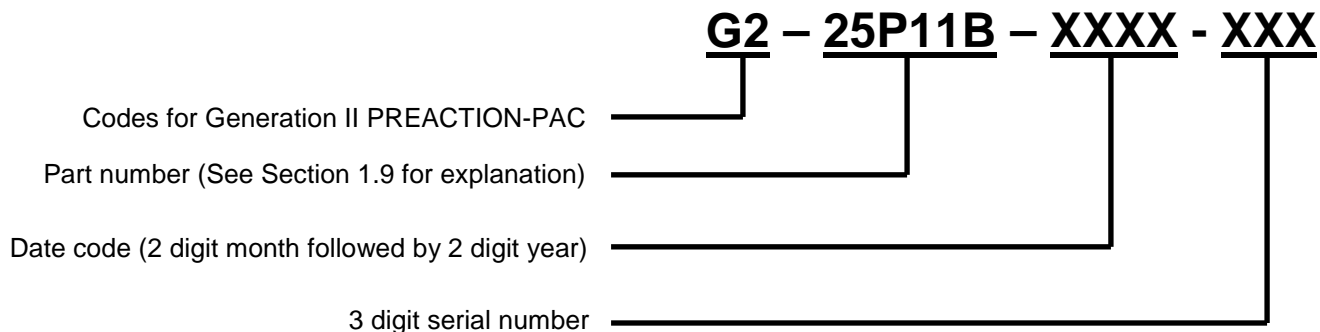


Figure 5 – Diagram - Location of Pallet Bolts and Leveling Feet

**1.10.3. Serial Number.** The serial number of each assembly is located on a permanent metal nameplate, located behind the upper enclosure door above the compressor disconnect switch. The serial number is coded as follows:




Note the serial number, date of installation, and date of commissioning on the front of this manual where indicated.

#### **1.10.4. External Attachments.**

**1.10.4.1. Pre-Action Valve.** Use Section 2 - Victaulic manual I-769P to guide the installation of inlet, outlet, and drain piping. See Figure 6 for details.

**1.10.4.1.1. Inlet Piping.** Inlet piping may be attached to the PREACTION-PAC in one of three locations:

- The standard connection is at the upper right corner of the lower enclosure. The assembly is pre-piped to accept inlet piping at this location. This location is labeled INLET. (NOTE: Assemblies equipped with 1/2HP compressors do not have upper right corner inlet connection. Use either lower left center or lower right center connection as described below.) Remove the plastic protection cap from the inlet pipe, and use a field-supplied grooved coupling to make this connection.
- An optional connection at the lower left center of the lower enclosure. Remove the pre-cut knockout from the lower left center of the lower enclosure. Remove the steel cap from the grooved coupling on the left side of the tee at the bottom of the enclosure. Attach the inlet piping to the left side of the tee using the grooved coupling. Remove the plastic protection cap from the top inlet connection, and assemble the steel cap removed from the tee to the top inlet connection using a field-supplied grooved coupling.



**CAUTION**

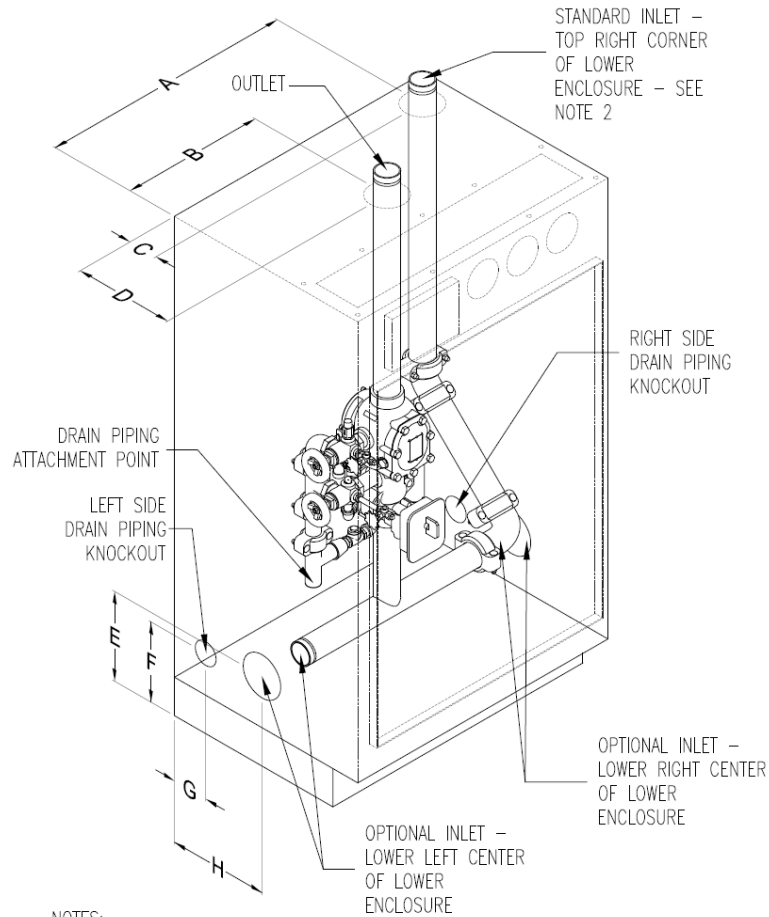
Failure to assemble the steel cap to the top inlet will result in property damage due to water escaping from the top inlet.

- An optional connection at the lower right center of the lower enclosure. Remove the pre-cut knockout from the lower right center of the lower enclosure. Remove the two grooved couplings from the elbow attached to the right side of the tee. (The elbow and one coupling may be discarded.) Attach the inlet piping to the right side of the tee using one of the grooved couplings. DO NOT attempt to remove any of the rest of the top inlet piping.

**1.10.4.1.2. Outlet Piping.** Outlet piping is attached to the PREACTION-PAC in one location; at the top center of the lower enclosure. This location is labeled OUTLET. Remove the plastic protection cap from the outlet pipe, and use a field-supplied grooved coupling to make this connection.

PREACTION-PAC  
with NOTIFIER NFS2-640 RELEASING CONTROL PANEL  
INSTALLATION, OPERATION, AND MAINTENANCE MANUAL  
P/N 10-500001-00B  
VERSION 1.1 – JULY 2011

**1.10.4.1.3. Drain Piping.** Drain piping is attached to the PREACTION-PAC at a nipple located in the lower enclosure. The drain pipe may exit the enclosure on either the left or right side. Remove the precut knockout from the chosen side. Attach the drain pipe to the nipple with two field-supplied grooved couplings and a field-supplied grooved elbow.



- NOTES:  
 1. TRIM ELEMENTS AND UPPER ENCLOSURE REMOVED FOR CLARITY  
 2. ASSEMBLIES EQUIPPED WITH 1/2HP COMPRESSORS DO NOT HAVE TOP INLET CONNECTION

Dimension	Assemblies with 1-1/2" thru 3" Pre-Action Valves	Assemblies with 4" Pre-Action Valves
A	26.64	26.14
B	15.00	15.00
C	3.11	3.61
D	10.50	12.50
E	9.36	9.86
F	8.36	8.86
G	3.75	5.75
H	10.50	12.50

NOTE: All units are in inches.

Figure 6 – Diagram - Piping Attachment

**1.10.4.2. Terminal Strip and Control Panel.** See Figure 7 for information on connection to the terminal strip in the upper enclosure. Use Section 4.1 – Notifier manual 52741 to guide the installation of connections to the control panel. Terminals for 110VAC power accept qty. (1) 10 ga. max. conductor. NOTE: All conductors used for field wiring must comply with NFPA 70 – National Electrical Code, and control panel manufacturer's instructions (see Section 4). See Section 4, page 39 for information on power-limited conductor runs.



DO NOT drill or punch the upper enclosure to attach conduit. Use the knockouts supplied at the lower back of the upper enclosure. Failure to follow these instructions can result in damage to the control panel. United Fire Protection Corporation will not be responsible for warranty adjustment of damaged control panels when these instructions are not followed.



This assembly contains static-sensitive components. ALWAYS ground yourself with a proper wrist strap before handling any electronic components or circuits. Failure to do so can lead to equipment damage from static electricity.

PREACTION-PAC  
with NOTIFIER NFS2-640 RELEASING CONTROL PANEL  
INSTALLATION, OPERATION, AND MAINTENANCE MANUAL  
P/N 10-500001-00B  
VERSION 1.1 – JULY 2011

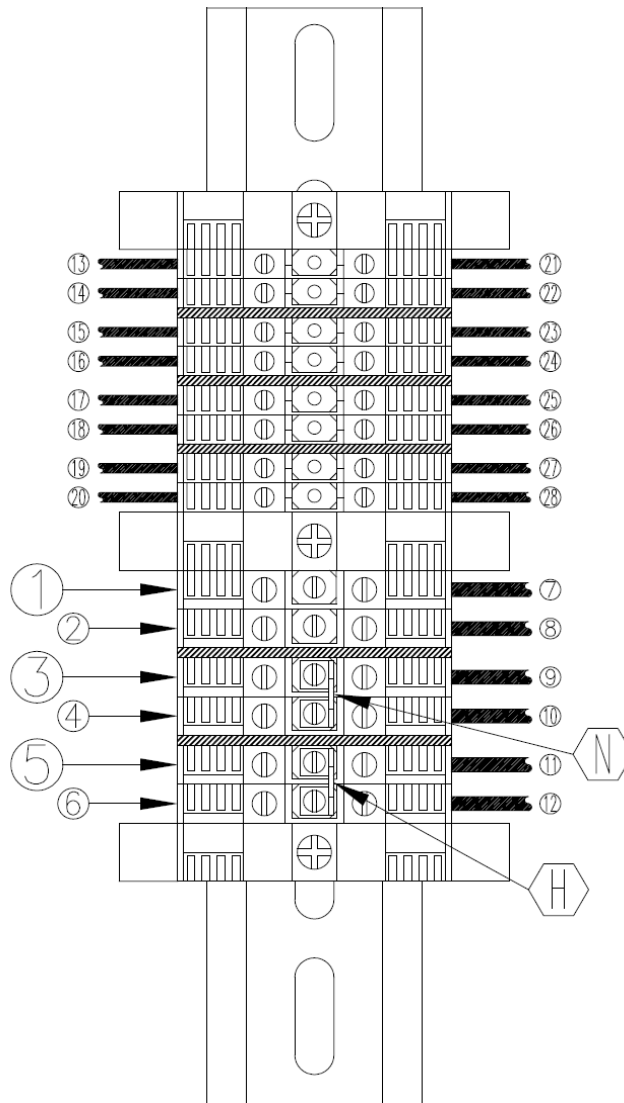


Figure 7 – Diagram - Terminal Strip Wiring Detail

PREACTION-PAC  
with NOTIFIER NFS2-640 RELEASING CONTROL PANEL  
INSTALLATION, OPERATION, AND MAINTENANCE MANUAL  
P/N 10-500001-00B  
VERSION 1.1 – JULY 2011

LEGEND			
FIELD WIRING			
	NO JUMPER USED	COLOR OF TERMINAL BLOCK	
1	DEDICATED 110 VAC GROUND FOR CONTROL PANEL (COMPRESSOR WILL ALSO BE GROUNDED THROUGH THIS TERMINAL)	GREEN/YELLOW	
2	DEDICATED 110 VAC GROUND FOR AIR COMPRESSOR (USE ONLY IF REQUIRED BY AHJ)	GREEN/YELLOW	
	WITH JUMPER(N) IN PLACE	WITH JUMPER(N) REMOVED	
3	110 VAC NEUTRAL FOR CONTROL PANEL AND COMPRESSOR	110 VAC NEUTRAL FOR CONTROL PANEL ONLY	WHITE
4	DO NOT USE	110 VAC NEUTRAL FOR COMPRESSOR ONLY	WHITE
	WITH JUMPER(H) IN PLACE	WITH JUMPER(H) REMOVED	
5	110 VAC HOT FOR CONTROL PANEL AND COMPRESSOR	110 VAC HOT FOR CONTROL PANEL ONLY	BLACK
6	DO NOT USE	110 VAC HOT FOR COMPRESSOR ONLY	BLACK
FACTORY WIRING			
7	110 VAC GROUND TO CONTROL PANEL	GREEN/YELLOW	
8	110 VAC GROUND TO AIR COMPRESSOR	GREEN/YELLOW	
9	110 VAC NEUTRAL TO CONTROL PANEL	WHITE	
10	110 VAC NEUTRAL TO AIR COMPRESSOR	WHITE	
11	110 VAC HOT TO CONTROL PANEL	BLACK	
12	110 VAC HOT TO AIR COMPRESSOR	BLACK	
13	PREACTION SOLENOID WIRING (-) FROM LOWER ENCLOSURE	GRAY	
14	PREACTION SOLENOID WIRING (+) FROM LOWER ENCLOSURE	RED	
15	LOW AIR SIGNAL SWITCH WIRING (NO) FROM LOWER ENCLOSURE	GRAY	
16	LOW AIR SIGNAL SWITCH WIRING (COM) FROM LOWER ENCLOSURE	GRAY	
17	WATERFLOW SIGNAL SWITCH WIRING (NO) FROM LOWER ENCLOSURE	BLUE	
18	WATERFLOW SIGNAL SWITCH WIRING (COM) FROM LOWER ENCLOSURE	BLUE	
19	TAMPER SIGNAL SWITCH WIRING (NO) FROM LOWER ENCLOSURE	YELLOW	
20	TAMPER SIGNAL SWITCH WIRING (COM) FROM LOWER ENCLOSURE	YELLOW	
21	PREACTION SOLENOID (-) TO CONTROL PANEL	GRAY	
22	PREACTION SOLENOID (+) TO CONTROL PANEL	RED	
23	LOW AIR SIGNAL SWITCH WIRING (NO) TO CONTROL PANEL	GRAY	
24	LOW AIR SIGNAL SWITCH WIRING (COM) TO CONTROL PANEL	GRAY	
25	WATERFLOW SIGNAL SWITCH WIRING (NO) TO CONTROL PANEL	BLUE	
26	WATERFLOW SIGNAL SWITCH WIRING (COM) TO CONTROL PANEL	BLUE	
27	TAMPER SIGNAL SWITCH WIRING (NO) TO CONTROL PANEL	YELLOW	
28	TAMPER SIGNAL SWITCH WIRING (COM) TO CONTROL PANEL	YELLOW	
JUMPERS			
(N)	CONNECTS CONTROL PANEL & COMPRESSOR 110 VAC NEUTRAL CONDUCTORS – REMOVE TO SEPARATE		
(H)	CONNECTS CONTROL PANEL & COMPRESSOR 110 VAC HOT CONDUCTORS – REMOVE TO SEPARATE		

Legend for Figure 7

**1.10.4.2.1. Power.** 110VAC, 3-wire, single-phase power is attached to the terminal strip in the upper enclosure. See Figure 7. Terminals for 110VAC power accept qty. (1) 10 ga. max. conductor. Current draw: With 1/6HP compressor = 10.6 amps; with 1/3HP compressor = 10.6 amps; with 1/2HP compressor = 12.0 amps.



Only qualified electricians should connect incoming power to the assembly. Failure to follow this instruction could result in death or serious personal injury.

- A. Turn off circuit breaker at the main power distribution panel.
- B. Connect service ground conductor to terminal marked GROUND.
- C. Connect primary neutral conductor to terminal marked NEUTRAL.
- D. Connect primary hot conductor to terminal marked HOT.

**1.10.4.2.2. Backup Batteries.** Calculate backup battery requirements, and connect backup batteries, per Section 4.1 – Notifier manual 52741. The upper enclosure is capable of holding batteries up to 26 A-H. If larger batteries are needed, use an external battery enclosure per Section 4.1 – Notifier manual 52741.

**1.10.4.2.3. Fire Detectors (Initiating Devices).** Fire detectors (initiating devices), located in the area protected by the sprinklers connected to the PREACTION-PAC, are necessary to provide the signal to open the pre-action valve. Refer to NFPA 72 for information on the number, type, and spacing of fire detectors. Install detectors, wiring, and panel connections per Section 4.1 – Notifier manual 52741. FM Approved systems / installations must be configured as Class A for Deluge and Preaction Releasing Service.

**1.10.4.2.4. Audible / Visual Appliances (Indicating Devices).** Audible / visual appliances (indicating devices), located in and around the area protected by the sprinklers connected to the PREACTION-PAC, are necessary to warn occupants that a fire has been detected. Refer to NFPA 72 for information on the number, type, and spacing of audible / visual appliances. Install audible / visual devices, wiring, and panel connections per Section 4.1 – Notifier manual 52741.

**1.10.4.2.5. Building Fire Alarm Systems.** In buildings with fire alarm systems separate from the PREACTION-PAC detection system, most national and local codes and authorities having jurisdiction require the PREACTION-PAC to provide signals to the building fire alarm system. The Notifier control panel installed in the PREACTION-PAC contains dry contacts capable of providing the necessary signals. Install audible / visual devices, wiring, and panel connections per Section 4.1 – Notifier manual 52741.

**1.10.4.2.6. Other Connections.** From time to time, additional signals from the PREACTION-PAC control panel may be required. Such signals can be associated with building management systems, equipment shutdown, or security notification. Additional dry contacts may be needed to satisfy all of these requirements.

**1.10.4.3. Compressor.** See Figure 7. 110VAC, 3-wire, single-phase power is attached to the terminal strip in the upper enclosure. The compressor power is factory-wired to the terminal strip in the upper enclosure. In the default configuration, the same 110VAC source used for the control panel serves for the compressor. If the local authority having jurisdiction requires separate power sources for the control panel and the compressor, jumpers can be removed from the terminal strip. The compressor pressure outlet is factory-attached to the system piping within the lower enclosure.

**1.10.4.4. Options** – None available at this time.



**1.10.5. Prior To Placing In Service.** Before placing the PREACTION-PAC in service, perform the following steps. Ensure that all discrepancies are corrected before proceeding to the next step.

- 1.10.5.1.** Ensure the entire system is installed per the latest revision of all applicable shop drawings.
- 1.10.5.2.** Ensure all testing has been performed on the sprinkler piping per the requirements of the authority having jurisdiction and NFPA 13.
- 1.10.5.3.** Use Sections 4.1, 4.2, and 4.3 – Notifier manuals 52741, 52743, and 52742 to perform all preliminary tests on the control panel, field wiring, and field devices.
- 1.10.5.4.** Use Section 2 – Victaulic manual I-769P to perform all preliminary tests on the pre-action valve, trim, and sprinkler piping.
- 1.10.5.5.** Perform all tests required to be witnessed by the authority having jurisdiction. Obtain AHJ approval of the installation.

**1.10.6. Placing In Service.**

- 1.10.6.1.** Verify that the control panel is indicating POWER ON, with no alarm or trouble indicators illuminated, and no error messages on the display.
- 1.10.6.2.** Verify that the water supply is on.
- 1.10.6.3.** Using Section 2 – Victaulic manual I-769P, verify that all valves are in the proper position for in-service status. Verify that the three pressure gages on the front of the lower enclosure are indicating expected values within expected limits.
- 1.10.6.4.** Ensure that the owner of the system has received adequate introductory training.
- 1.10.6.5.** Turn over this manual and the enclosure door keys to the owner. The manual may be stored in the pocket on the inside of the lower enclosure door.

**1.11. Operation.**

- 1.11.1. Automatic.** Fully automatic operation of the system will be conducted by the control panel. Power from 110VAC and / or batteries is required for the control panel to function in this way. No manual intervention is required for the control panel to perform its functions. Manual intervention to acknowledge and silence signals may be performed. Refer to Section 4.2 – Notifier manual 52743 for information on signals.



**IMPORTANT**

Fusing of a sprinkler head by heat is necessary for water to be discharged onto a fire, even after operation of automatic fire detectors.

- 1.11.2. Manual.** Manual operation of the pre-action valve is accomplished with the manual release valve. Open the door marked IN CASE OF FIRE OPEN DOOR AND PULL LEVER. No key is needed to open this door. Pull the lever. No power is needed to open the pre-action valve in this manner. The door may not be closed until the lever is restored to its normal position.



**IMPORTANT**

Fusing of a sprinkler head by heat is necessary for water to be discharged onto a fire, even after operation of the manual station valve.

**1.11.3. Restoring To Service.** After automatic or manual system operation, follow instructions in Section 2 – Victaulic manual I-769P and Section 4.2 – Notifier manual 52743 to restore the individual parts of the PREACTION-PAC to service.

**1.12. Inspection, Testing, and Maintenance.** Regular inspection, testing and maintenance of the PREACTION-PAC assembly is essential to the assembly's continued proper operation. Follow all instructions in the documents described in this section. Pay particular attention to the required minimum interval for each item of inspection, testing, and maintenance. The owner of the system (or their designated representative) is responsible for the overall condition of the system, and ensuring that all inspection, testing, and maintenance items are conducted as recommended.



**IMPORTANT**

The United Fire Protection PREACTION-PAC sprinkler valve assembly is a vital part of the fire protection of any facility where these units are installed. Life safety and property protection depends on continuing proper operation of the assembly. The owner of the PREACTION-PAC is responsible for the condition of the assembly and its continued proper operation. United Fire Protection strongly recommends that all owners of PREACTION-PACs engage the services of qualified, trained fire protection professionals to inspect, test, maintain, and repair the assembly.

**1.12.1. Inspection.** Inspection involves carrying out a set of procedures to discover and note any and all discrepancies that could render the system impaired, inoperative, or ineffective. The result of an inspection is a comprehensive list of these discrepancies. Inspection does not specifically include maintenance or repair; however, maintenance and repair can be and usually is conducted at the time of inspection.

**1.12.2. Testing.** Testing involves carrying out procedures to discover if tested components function as intended. Testing is an integral part of performing inspection. Testing is also done after the performance of some maintenance procedures.

**1.12.3. Maintenance.** Maintenance involves carrying out procedures to ensure that maintained components continue to function as intended. Maintenance is usually preventive in nature. Maintenance can be conducted during inspection.

**1.12.4. Repair.** Repair involves carrying out procedures to correct the deficiencies found during inspection, or as a result of other events such as system actuation or control panel trouble / alarm signals.

PREACTION-PAC  
with NOTIFIER NFS2-640 RELEASING CONTROL PANEL  
INSTALLATION, OPERATION, AND MAINTENANCE MANUAL  
P/N 10-500001-00B  
VERSION 1.1 – JULY 2011

**1.12.5. Documents Relevant To Inspection, Testing, Maintenance, and Repair.**

**1.12.5.1.** Victaulic Manual I-769P.

**1.12.5.2.** General Air Products Manual OILLESSINST.

**1.12.5.3.** Notifier Manual 52741.

**1.12.5.4.** Notifier Manual 52743.

**1.12.5.5.** Notifier Manual 52742.

**1.12.5.6.** National Fire Protection Association No. 25, "Standard for the Inspection, Testing, and Maintenance of Water-Based Fire Protection Systems."

**1.12.5.7.** National Fire Protection Association No. 72, "National Fire Alarm Code®"

# SECTION

# 2

Victaulic Manual I-769P

Firelock NXT Preaction  
Valve

# FireLock NXT™ Preaction Valve

SERIES 769

NON-INTERLOCKED, PNEUMATIC RELEASE WITH SERIES 776 LOW-PRESSURE ACTUATOR

NON-INTERLOCKED, PNEUMATIC/ELECTRIC RELEASE WITH SERIES 776 LOW-PRESSURE ACTUATOR AND SERIES 753-E SOLENOID VALVE

SINGLE-INTERLOCKED, PNEUMATIC RELEASE WITH SERIES 776 LOW-PRESSURE ACTUATOR

SINGLE-INTERLOCKED, ELECTRIC RELEASE WITH SERIES 753-E SOLENOID VALVE

DOUBLE-INTERLOCKED, ELECTRIC (ELECTRIC-PNEUMATIC/ELECTRIC) RELEASE WITH SERIES 753-E SOLENOID VALVE

HANG THESE INSTRUCTIONS ON THE  
INSTALLED VALVE FOR EASY FUTURE REFERENCE



WARNING



## WARNING



- Failure to follow instructions and warnings can cause product failure, resulting in serious personal injury and property damage.
- Read and understand all instructions before attempting to install any Victaulic piping products.
- Wear safety glasses, hardhat, and foot protection.
- Save this installation, maintenance, and testing manual for future reference.

If you need additional copies of any literature, or if you have any questions concerning the safe installation and operation of this product, contact Victaulic, P.O. Box 31, Easton, PA 18044-0031, USA, Telephone: 1-800 PICK VIC, e-mail: pickvic@victaulic.com.



# FireLock NXT™ Preaction Valve

SERIES 769

## TABLE OF CONTENTS

Hazard Identification . . . . . 1

Installer Safety Instructions . . . . . 2

    General . . . . . 2

    Maintenance and Testing . . . . . 2

Introduction . . . . . 3

Trim Dimensions . . . . . 3

Exploded View Drawing – Trim Components . . . . . 4

Exploded View Drawing – Trim Components . . . . . 5

Exploded View Drawing – Trim Components . . . . . 6

Exploded View Drawing – Trim Components . . . . . 7

Exploded View Drawing – Internal Valve Components . . . . . 8

Section View Drawing and Description –  
Series 776 Low-Pressure Actuator . . . . . 9

Section View Drawing and Description –  
Series 746-LPA Dry Accelerator . . . . . 10

Air Supply Requirements . . . . . 11

    Compressor Sizing . . . . . 11

    Base or Riser-Mounted Air Compressors . . . . . 11

    Shop Air or Tank-Mounted Air Compressors . . . . . 11

    Victaulic Series 757 Regulated Air Maintenance  
    Trim Assembly (AMTA) Option . . . . . 11

    Victaulic Series 757P Air Maintenance Trim Assembly  
    (AMTA) with Pressure Switch Option . . . . . 12

    Compressor Requirements and Settings for  
    Series 769 FireLock NXT Preaction Valves  
    Installed with Series 746-LPA Dry Accelerators . . . . . 12

    Settings for Air Supervisory Pressure Switches  
    and Alarm Pressure Switches . . . . . 12

    Remote System Test Valve Requirements . . . . . 12

Important Installation Information . . . . . 13

Valve/Trim Installation . . . . . 13

    Compression Fitting and Tube Installation . . . . . 14

Hydrostatic Testing . . . . . 14

Placing the System in Service . . . . . 15

External Inspection . . . . . 21

    Weekly Inspection . . . . . 21

    Monthly Inspection . . . . . 21

Required Tests . . . . . 22

    Main Drain Test . . . . . 22

    Water Flow Alarm Test . . . . . 24

    Water Level and Low Air Alarm Tests . . . . . 25

Required Operational (Trip) Tests . . . . . 29

    Partial Operational (Trip) Test . . . . . 29

    Full Operational (Trip) Test . . . . . 31

Required Internal Inspection . . . . . 33

Maintenance . . . . . 36

    Removing and Replacing the Clapper Seal . . . . . 36

    Removing and Replacing the Clapper Assembly . . . . . 38

    Installing the Cover Plate Gasket and Cover Plate . . . . . 40

    Removing and Replacing the Diaphragm Assembly . . . . . 41

    Replacing the Strainer Screen for  
    Series 776 Low-Pressure Actuators . . . . . 42

Troubleshooting – Series 776 Low-Pressure Actuator . . . . . 43

Troubleshooting – Series 753-E Solenoid Valve . . . . . 43

Troubleshooting – Series 746-LPA Dry Accelerator . . . . . 43

Troubleshooting – System . . . . . 44

## HAZARD IDENTIFICATION



Definitions for identifying the various hazard levels are provided below. When you see this symbol, be alert to the possibility of personal injury. Carefully read and fully understand the message that follows.

**WARNING**

- The use of the word “WARNING” identifies the presence of hazards or unsafe practices that could result in death or serious personal injury if instructions, including recommended precautions, are not followed.

**CAUTION**

- The use of the word “CAUTION” identifies possible hazards or unsafe practices that could result in personal injury and product or property damage if instructions, including recommended precautions, are not followed.




**NOTICE**

- The use of the word “NOTICE” identifies special instructions that are important but not related to hazards.

## FireLock NXT™ Preaction Valve

SERIES 769

### INSTALLER SAFETY INSTRUCTIONS

 <b>WARNING</b>	
	<ul style="list-style-type: none"> <li>• An experienced, trained installer must install this product in accordance with all instructions. These instructions contain important information.</li> </ul>
	<ul style="list-style-type: none"> <li>• Depressurize and drain the piping system before attempting to install, remove, adjust, or maintain any Victaulic piping products.</li> </ul> <p>Failure to follow these instructions can cause product failure, resulting in serious personal injury and/or property damage.</p>

#### GENERAL

1. **Read and understand all instructions and refer to the trim diagrams before proceeding with the installation, maintenance, and testing of this Victaulic Series 769 FireLock NXT Preaction Valve.**
2. **Inspect the shipment.** Make sure all components are included in the shipment and that all necessary tools are available for installation.
3. **Use only recommended accessories.** Accessories and equipment that are not approved for use with this valve may cause improper system operation.
4. **Wear safety glasses, hardhat, foot protection, and hearing protection.** Wear hearing protection if you are exposed to long periods of noisy job-site operations.
5. **Prevent back injury.** Larger and pre-trimmed valves are heavy and require more than one person or mechanical lifting equipment to position and install the assembly. Always practice proper lifting techniques.
6. **Avoid using electrically powered tools in dangerous environments.** When using electrically powered tools for installation, make sure the area is moisture-free. Keep the work area well lit, and allow enough space to accommodate proper installation of the valve, trim, and accessories.
7. **Watch for pinch points.** Do not place fingers under the valve body where they could be pinched by the weight of the valve. Use caution around spring-loaded components (i.e. clapper assembly).
8. **Keep work areas clean.** Cluttered areas, benches, and slippery floors can create hazardous working conditions.
9. **PROTECT THE SYSTEM FROM FREEZING CONDITIONS. THE VALVE AND SUPPLY PIPING MUST BE PROTECTED FROM FREEZING TEMPERATURES AND MECHANICAL DAMAGE.**
10. **IF THE INLET WATER SUPPLY IS INTERRUPTED FOR ANY REASON, AND SYSTEM SUPPLY PRESSURE TO THE VALVE DECREASES, MAKE SURE THE DIAPHRAGM CHARGE LINE IS FULLY PRESSURIZED BEFORE PLACING THE SYSTEM BACK IN SERVICE.**

#### MAINTENANCE AND TESTING

1. **Notify the authority having jurisdiction.** Always notify the authority having jurisdiction before performing any maintenance that eliminates the fire protection provided by the system.
2. **Follow NFPA requirements for system testing and inspection schedules.** The building owner or their representative is responsible for inspecting the system in accordance with current NFPA-25 requirements or in accordance with the requirements of the local authority having jurisdiction (whichever is more stringent).
3. **Depressurize and drain the system completely before performing any maintenance.** Water under pressure can cause the cover plate to blow off during removal if the system is not depressurized and drained completely.
4. **Protect the valve from freezing temperatures, foreign matter, and corrosive atmospheres.** Any condition that might degrade the system or affect system performance must be avoided.



# FireLock NXT™ Preaction Valve

SERIES 769

## INTRODUCTION

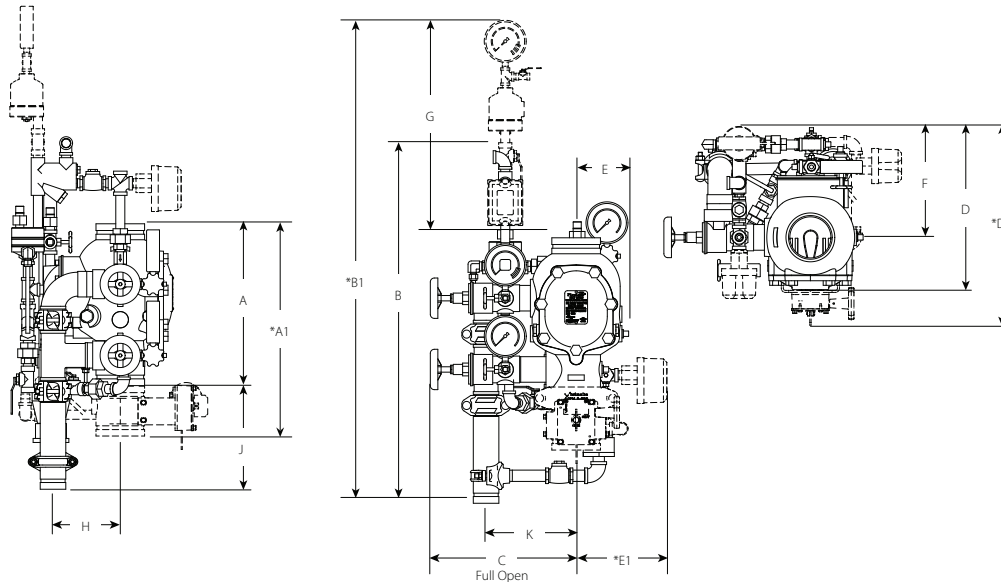
The following instructions are a guide for proper installation of Victaulic Series 769 FireLock NXT Preaction Valves. These instructions involve pipe that is properly prepared and grooved in accordance with current Victaulic specifications.

### NOTICE

- Drawings and/or pictures in this manual may be exaggerated for clarity.
- This product and this installation, maintenance, and testing manual contain trademarks, copyrights, and/or patented features that are the exclusive property of Victaulic.

## TRIM DIMENSIONS

THE 4-INCH/114.3-MM CONFIGURATION IS SHOWN BELOW. 1 ½ – 2-INCH/48.3 – 60.3-MM CONFIGURATIONS CONTAIN ¼-INCH/19-MM DRAIN VALVES. 2 ½ – 3-INCH/73.0 – 88.9-MM CONFIGURATIONS CONTAIN 1 ¼-INCH/31-MM DRAIN VALVES. 4 – 8-INCH/114.3 – 219.1-MM CONFIGURATIONS CONTAIN 2-INCH/50-MM DRAIN VALVES.



Size		Dimensions – inches/mm														Aprx. Weight Ea. lbs/kg	
Nominal Size inches	Actual Out. Dia. inches	A	A1*	B	B1*	C	D	D1*	E	E1*	F	G	H	J	K	Without Trim	With Trim
1 ½	1.900	9.00	16.43	28.25	40.50	13.75	16.00	—	5.25	8.50	9.50	22.25	3.04	9.17	6.98	16.7	43.0
40	48.3	228.60	417.32	717	1028	349	406	—	133	215	241	565	77.21	232.91	177.29	7.6	19.5
2	2.375	9.00	16.43	28.25	40.50	13.75	16.00	—	5.25	8.50	9.50	22.25	3.04	9.17	6.98	17.0	43.0
50	60.3	228.60	417.32	717	1028	349	406	—	133	215	241	565	77.21	232.91	177.29	7.7	19.5
2 ½	2.875	12.61	16.50	32.25	44.25	13.50	16.00	17.50	5.25	9.00	9.25	21.25	3.90	10.50	6.93	41.0	65.0
65	73.0	320.29	419.10	819	1123	342	406	444	133	228	234	539	99.06	266.70	176.02	18.7	29.5
76.1 mm	3.000	12.61	16.50	32.25	44.25	13.50	16.00	17.50	5.25	9.00	9.25	21.25	3.90	10.50	6.93	41.0	65.0
	76.1	320.29	419.10	819	1123	342	406	444	133	228	234	539	99.06	266.70	176.02	18.7	29.5
3	3.500	12.61	16.50	32.25	44.25	13.50	16.00	17.50	5.25	9.00	9.25	21.25	3.90	10.50	6.93	41.0	65.0
80	88.9	320.29	419.10	819	1123	342	406	444	133	228	234	539	99.06	266.70	176.02	18.7	29.5
4	4.500	15.03	19.78	33.25	45.50	15.00	15.75	20.50	5.50	9.00	10.75	20.75	6.25	9.62	8.46	59.0	95.0
100	114.3	381.76	502.41	844	1155	381	400	520	139	228	273	527	158.75	244.34	214.88	26.7	43.0
165.1 mm	6.500	16.00	22.00	33.50	45.75	15.50	17.00	22.00	6.00	8.50	11.50	20.00	6.20	9.62	8.84	80.0	116.0
	165.1	406.40	558.80	850	1162	393	431	558	152	215	292	508	157.48	244.34	224.53	36.2	52.6
6	6.625	16.00	22.00	33.50	45.75	15.50	17.00	22.00	6.00	8.50	11.50	20.00	6.20	9.62	8.84	80.0	116.0
150	168.3	406.40	558.80	850	1162	393	431	558	152	215	292	508	157.48	244.34	224.53	36.2	52.6
8	8.625	17.50	22.94	33.50	45.50	16.75	20.00	25.25	7.00	8.75	12.75	18.50	6.05	9.40	10.21	122.0	158.0
200	219.1	444.50	582.67	850	1155	425	508	641	177	222	323	469	153.67	238.76	259.33	55.3	71.6

### NOTES:

The drawings shown above reflect the single-interlocked, pneumatic release trim with Series 776 Low-Pressure Actuator. In addition, these dimensions can be applied to single-interlocked, pneumatic release; non-interlocked, pneumatic/electric release; single-interlocked, electric release; and double-interlocked, electric (electric-pneumatic/electric) release trim.

The "A" dimension coupling is not shown for clarity.

Components shown as dotted lines denote optional equipment

\* Measurements denoted with an asterisk take optional equipment into account

Optional drain connection kit is shown for reference and takeout dimensions.

# FireLock NXT™ Preaction Valve

SERIES 769

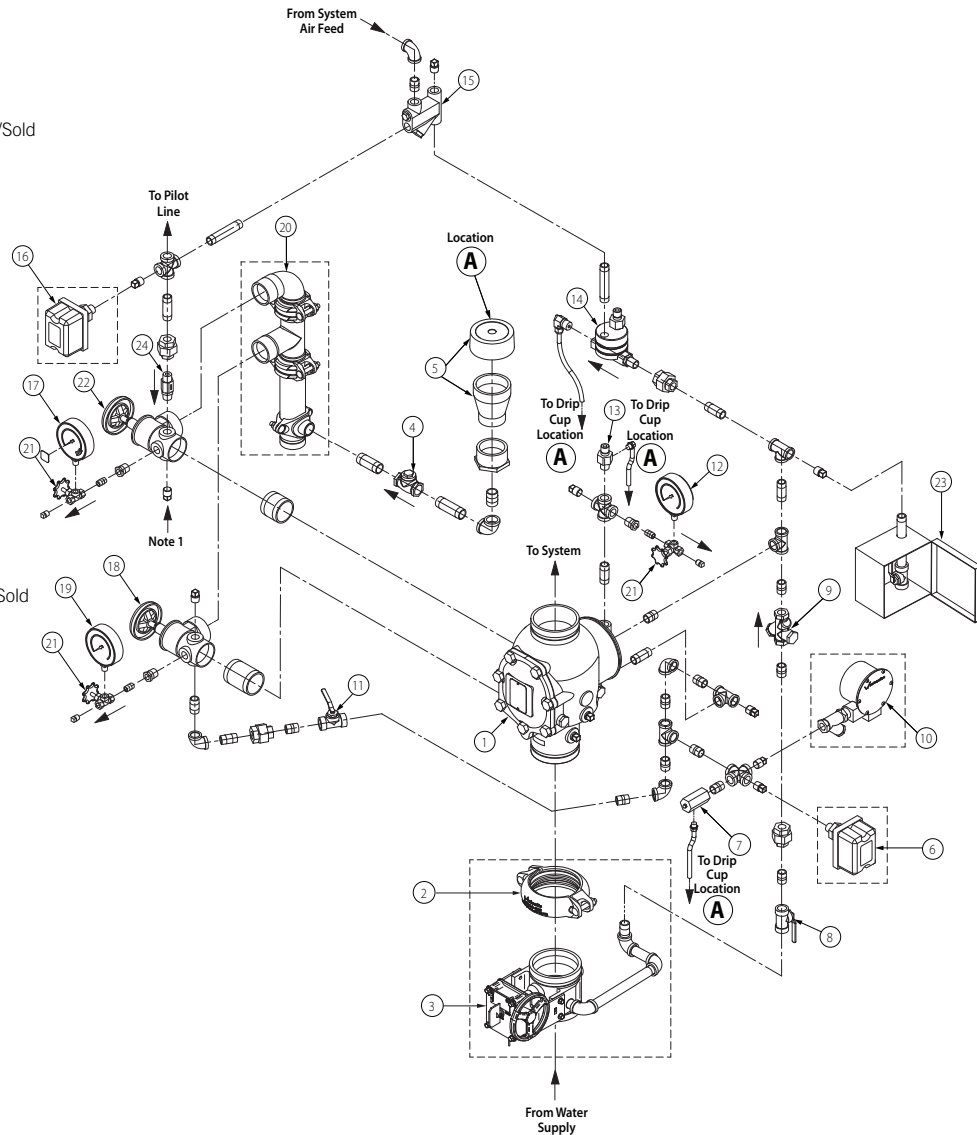
## EXPLODED VIEW DRAWING – TRIM COMPONENTS

SERIES 769 FIRELOCK NXT PREACTION VALVE – NON-INTERLOCKED, PNEUMATIC RELEASE TRIM (OPTIONAL ACCESSORIES ALSO SHOWN)



**Bill of Materials**

- 1 Series 769 FireLock NXT Preaction Valve
- 2 FireLock Rigid Coupling (Optional/Sold Separately – Comes Standard when VQR Assembly is Ordered)
- 3 Water Supply Main Control Valve (Optional/Sold Separately – Comes Standard when VQR Assembly is Ordered)
- 4 Drain Swing Check Valve
- 5 Drip Cup with Cap
- 6 Alarm Pressure Switch (Optional/Sold Separately – Comes Standard when VQR Assembly is Ordered)
- 7 Series 729 Drip Check Valve
- 8 Diaphragm-Charge-Line Ball Valve (Normally Open)
- 9 3-in-1 Strainer/Check/Restrictor Assembly
- 10 Series 760 Water Motor Alarm (Optional/Sold Separately)
- 11 Alarm Test Ball Valve
- 12 Diaphragm-Charge-Line Pressure Gauge (0-300 psi/0-2068 kPa/0-20.7 Bar)
- 13 Series 749 Auto Drain
- 14 Series 776 Low-Pressure Actuator
- 15 Air Manifold
- 16 Air Supervisory Pressure Switch (Optional/Sold Separately – Comes Standard when VQR Assembly is Ordered)
- 17 System Pressure Gauge (0-80 psi/0-552 kPa/0-5.5 Bar with Retard)
- 18 Water Supply Main Drain Valve - Flow Test
- 19 Water Supply Pressure Gauge (0-300 psi/0-2068 kPa/0-20.7 Bar)
- 20 Drain Connection Kit (Optional/Sold Separately – Comes Standard when VQR Assembly is Ordered)
- 21 Gauge Valve
- 22 System Main Drain Valve
- 23 Series 755 Manual Pull Station
- 24 Series 748 Ball Check Valve



**NOTE 1:** Connection point for the Series 75D Water Column Device Kit

For information regarding installation of the Series 75B Supplemental Alarm Device or the Series 7C7 Air Maintenance/Compressor Assembly (not shown), refer to the instructions supplied with the product.

# FireLock NXT™ Preaction Valve

SERIES 769

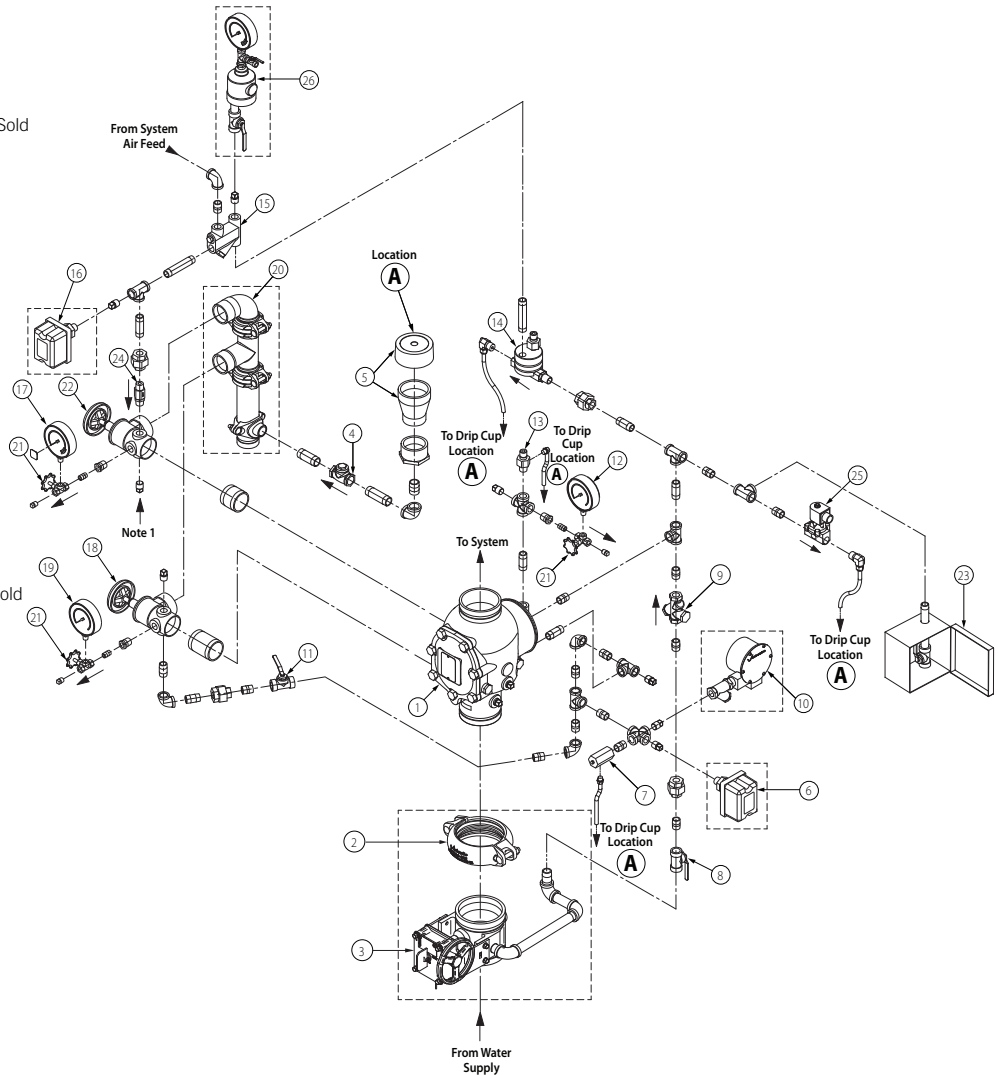
## EXPLODED VIEW DRAWING – TRIM COMPONENTS

SERIES 769 FIRELOCK NXT PREACTION VALVE – NON-INTERLOCKED, PNEUMATIC/ELECTRIC RELEASE TRIM (OPTIONAL ACCESSORIES ALSO SHOWN)



**Bill of Materials**

- 1 Series 769 FireLock NXT Preaction Valve
- 2 FireLock Rigid Coupling (Optional/Sold Separately – Comes Standard when VQR Assembly is Ordered)
- 3 Water Supply Main Control Valve (Optional/Sold Separately – Comes Standard when VQR Assembly is Ordered)
- 4 Drain Swing Check Valve
- 5 Drip Cup with Cap
- 6 Alarm Pressure Switch (Optional/Sold Separately – Comes Standard when VQR Assembly is Ordered)
- 7 Series 729 Drip Check Valve
- 8 Diaphragm-Charge-Line Ball Valve (Normally Open)
- 9 3-in-1 Strainer/Check/Restrictor Assembly
- 10 Series 760 Water Motor Alarm (Optional/Sold Separately)
- 11 Alarm Test Ball Valve
- 12 Diaphragm-Charge-Line Pressure Gauge (0-300 psi/0-2068 kPa/0-20.7 Bar)
- 13 Series 749 Auto Drain
- 14 Series 776 Low-Pressure Actuator
- 15 Air Manifold
- 16 Air Supervisory Pressure Switch (Optional/Sold Separately – Comes Standard when VQR Assembly is Ordered)
- 17 System Pressure Gauge (0-80 psi/0-552 kPa/0-5.5 Bar with Retard)
- 18 Water Supply Main Drain Valve - Flow Test
- 19 Water Supply Pressure Gauge (0-300 psi/0-2068 kPa/0-20.7 Bar)
- 20 Drain Connection Kit (Optional/Sold Separately – Comes Standard when VQR Assembly is Ordered)
- 21 Gauge Valve
- 22 System Main Drain Valve
- 23 Series 755 Manual Pull Station
- 24 Series 748 Ball Check Valve
- 25 Series 753-E Solenoid Valve
- 26 Series 746-LPA Dry Accelerator (Optional/Sold Separately)



**NOTE 1:** Connection point for the Series 75D Water Column Device Kit

For information regarding installation of the Series 75B Supplemental Alarm Device or the Series 7C7 Air Maintenance/Compressor Assembly (not shown), refer to the instructions supplied with the product.

# FireLock NXT™ Preaction Valve

SERIES 769

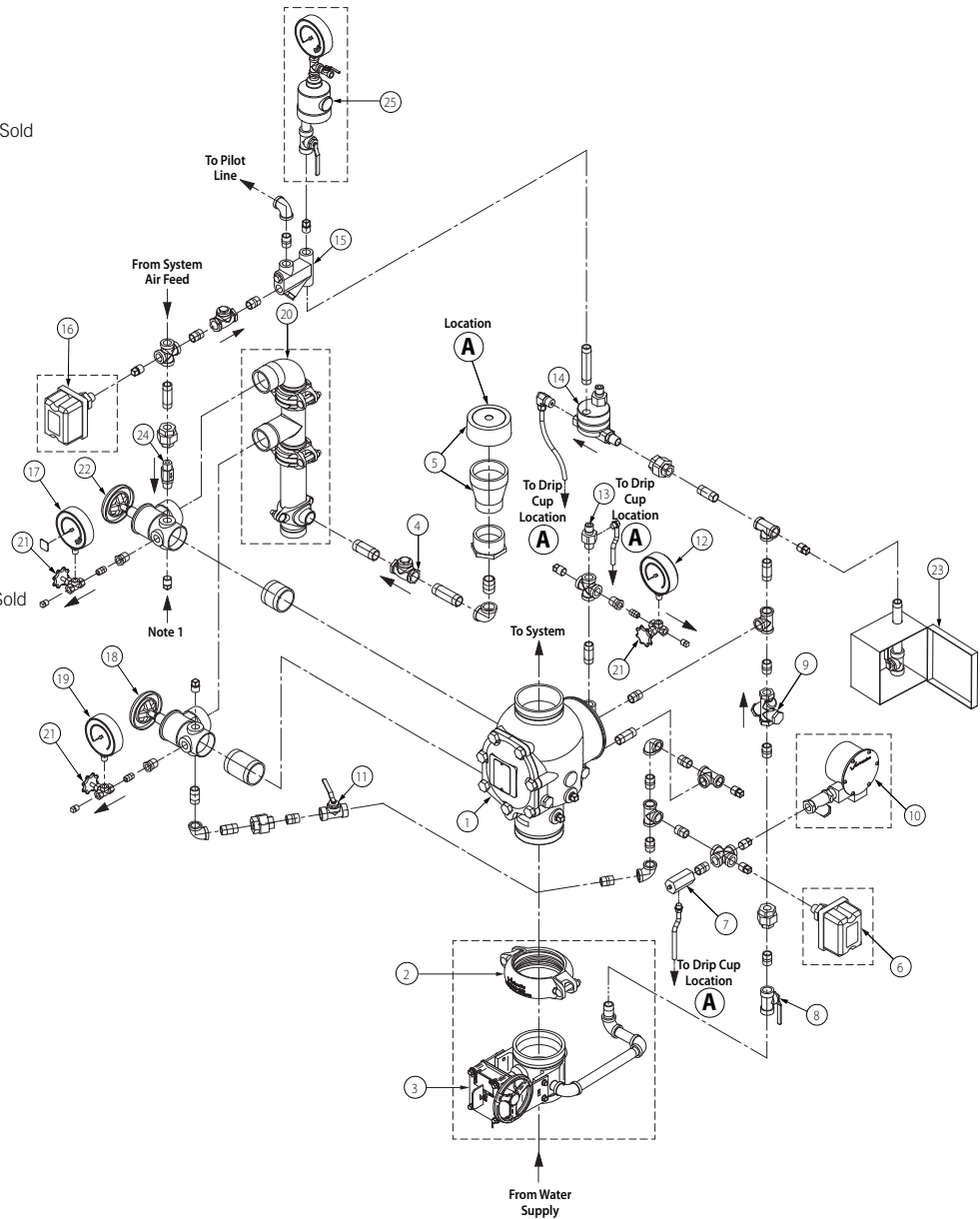
## EXPLODED VIEW DRAWING – TRIM COMPONENTS

SERIES 769 FIRELOCK NXT PREACTION VALVE – SINGLE-INTERLOCKED, PNEUMATIC RELEASE TRIM (OPTIONAL ACCESSORIES ALSO SHOWN)



**Bill of Materials**

- 1 Series 769 FireLock NXT Preaction Valve
- 2 FireLock Rigid Coupling (Optional/Sold Separately – Comes Standard when VQR Assembly is Ordered)
- 3 Water Supply Main Control Valve (Optional/Sold Separately – Comes Standard when VQR Assembly is Ordered)
- 4 Drain Swing Check Valve
- 5 Drip Cup with Cap
- 6 Alarm Pressure Switch (Optional/Sold Separately – Comes Standard when VQR Assembly is Ordered)
- 7 Series 729 Drip Check Valve
- 8 Diaphragm-Charge-Line Ball Valve (Normally Open)
- 9 3-in-1 Strainer/Check/Restrictor Assembly
- 10 Series 760 Water Motor Alarm (Optional/Sold Separately)
- 11 Alarm Test Ball Valve
- 12 Diaphragm-Charge-Line Pressure Gauge (0-300 psi/0-2068 kPa/0-20.7 Bar)
- 13 Series 749 Auto Drain
- 14 Series 776 Low-Pressure Actuator
- 15 Air Manifold
- 16 Air Supervisory Pressure Switch (Optional/Sold Separately – Comes Standard when VQR Assembly is Ordered)
- 17 System Pressure Gauge (0-80 psi/0-552 kPa/0-5.5 Bar with Retard)
- 18 Water Supply Main Drain Valve - Flow Test
- 19 Water Supply Pressure Gauge (0-300 psi/0-2068 kPa/0-20.7 Bar)
- 20 Drain Connection Kit (Optional/Sold Separately – Comes Standard when VQR Assembly is Ordered)
- 21 Gauge Valve
- 22 System Main Drain Valve
- 23 Series 755 Manual Pull Station
- 24 Series 748 Ball Check Valve
- 25 Series 746-LPA Dry Accelerator (Optional/Sold Separately)



**NOTE 1:** Connection point for the Series 75D Water Column Device Kit

For information regarding installation of the Series 75B Supplemental Alarm Device or the Series 7C7 Air Maintenance/Compressor Assembly (not shown), refer to the instructions supplied with the product.

# FireLock NXT™ Preaction Valve

SERIES 769

## EXPLODED VIEW DRAWING – TRIM COMPONENTS

SERIES 769 FIRELOCK NXT PREACTION VALVE – SINGLE-INTERLOCKED, ELECTRIC RELEASE TRIM

SERIES 769 FIRELOCK NXT PREACTION VALVE – DOUBLE-INTERLOCKED, ELECTRIC RELEASE (ELECTRIC-PNEUMATIC/ELECTRIC) TRIM

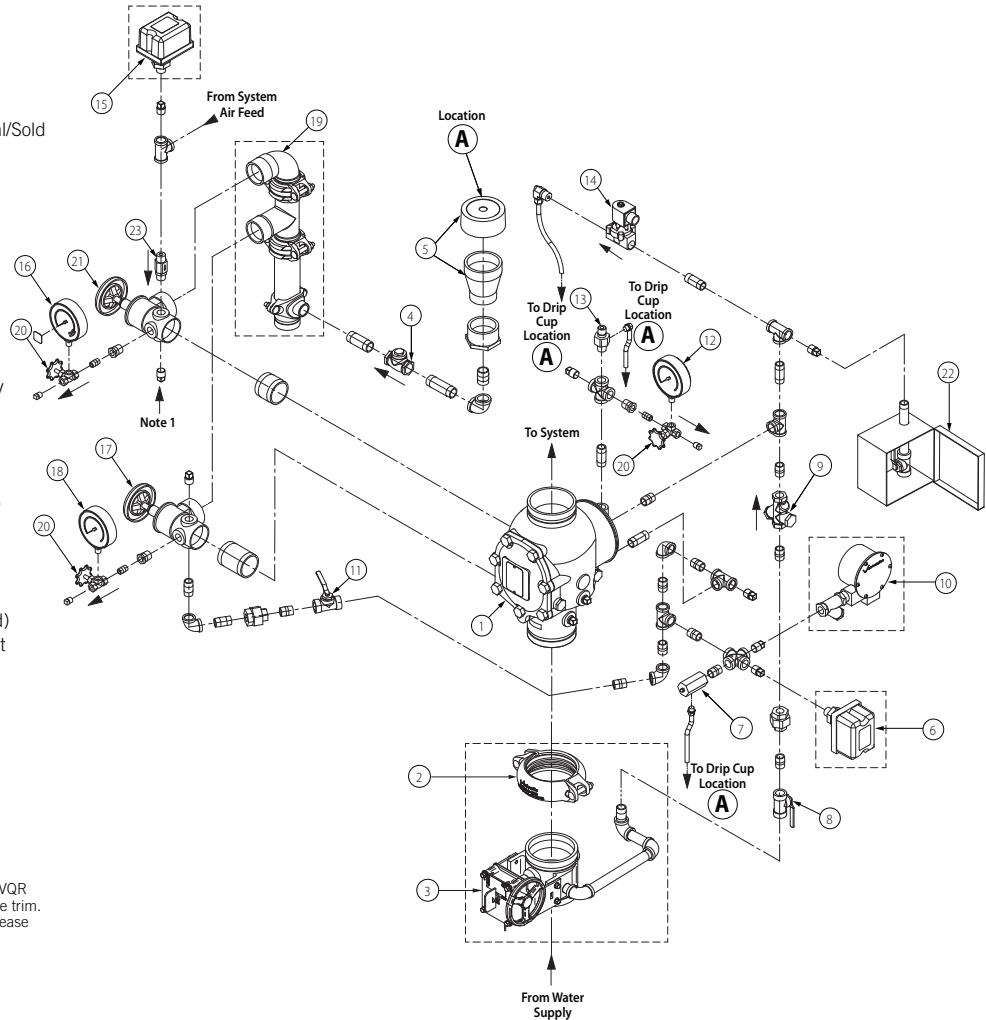


(OPTIONAL ACCESSORIES ALSO SHOWN)

**Bill of Materials**

- 1 Series 769 FireLock NXT Preaction Valve
- 2 FireLock Rigid Coupling (Optional/Sold Separately – Comes Standard when VQR Assembly is Ordered)
- 3 Water Supply Main Control Valve (Optional/Sold Separately – Comes Standard when VQR Assembly is Ordered)
- 4 Drain Swing Check Valve
- 5 Drip Cup with Cap
- 6 Alarm Pressure Switch (Optional/Sold Separately – Comes Standard when VQR Assembly is Ordered)
- 7 Series 729 Drip Check Valve
- 8 Diaphragm-Charge-Line Ball Valve (Normally Open)
- 9 3-in-1 Strainer/Check/Restrictor Assembly
- 10 Series 760 Water Motor Alarm (Optional/Sold Separately)
- 11 Alarm Test Ball Valve
- 12 Diaphragm-Charge-Line Pressure Gauge (0-300psi/0-2068kPa/0-20.7 Bar)
- 13 Series 749 Auto Drain
- 14 Series 753-E Solenoid Valve
- 15 Air Supervisory Pressure Switch\*\*
- 16 System Pressure Gauge (0-80psi/0-552kPa/0-5.5 Bar with Retard)
- 17 Water Supply Main Drain Valve - Flow Test
- 18 Water Supply Pressure Gauge (0-300psi/0-2068kPa/0-20.7 Bar)
- 19 Drain Connection Kit (Optional/Sold Separately – Comes Standard when VQR Assembly is Ordered)
- 20 Gauge Valve
- 21 System Main Drain Valve
- 22 Series 755 Manual Pull Station
- 23 Series 748 Ball Check Valve

\*\*Item #15 is optional/sold separately (or standard when VQR assembly is ordered) for single-interlocked, electric release trim.  
 \*\*Item #15 is standard for double-interlocked, electric release (electric-pneumatic/electric) trim.



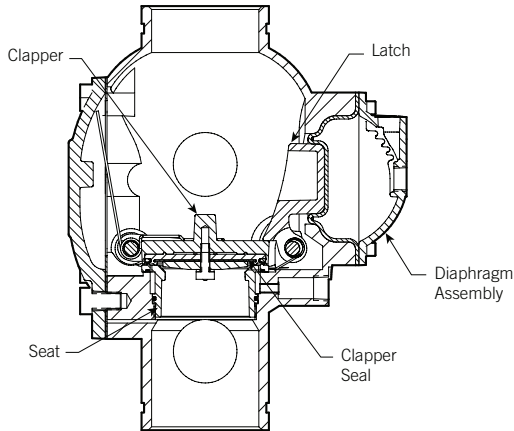
**NOTE 1:** Connection point for the Series 75D Water Column Device Kit

For information regarding installation of the Series 75B Supplemental Alarm Device or the Series 7C7 Air Maintenance/Compressor Assembly (not shown), refer to the instructions supplied with the product.

# FireLock NXT™ Preaction Valve

SERIES 769

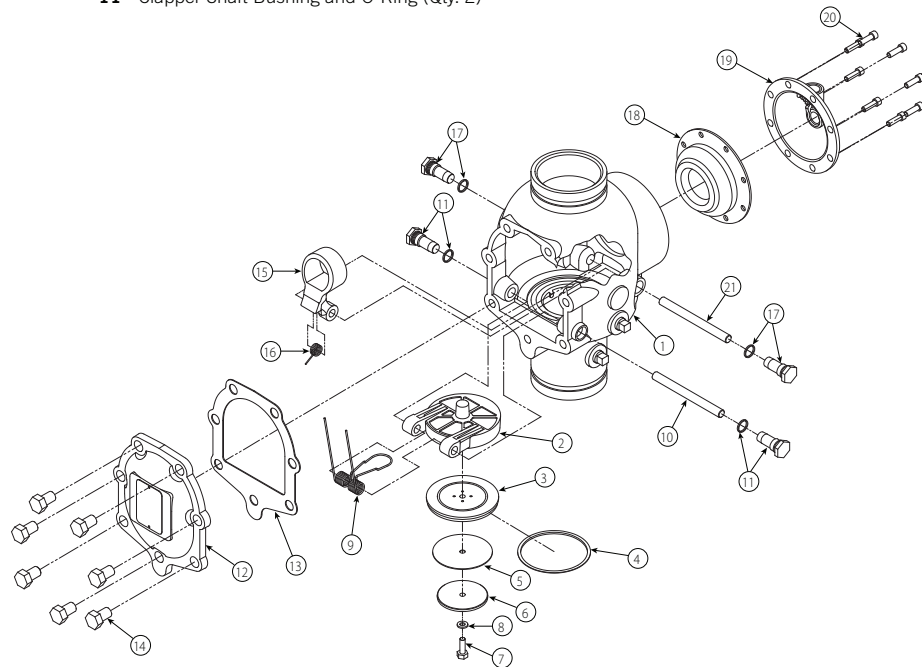
## EXPLODED VIEW DRAWING – INTERNAL VALVE COMPONENTS



NOTE: VALVE IS SHOWN ABOVE IN THE "SET" POSITION  
*Exaggerated for Clarity*

**Bill of Materials**

- |  |  |
|--|--|
| 1 Valve Body                                 | 12 Cover Plate                             |
| 2 Clapper                                    | 13 Cover Plate Gasket                      |
| 3 Clapper Seal                               | 14 Cover Plate Bolts*                      |
| 4 Seal Ring                                  | 15 Latch                                   |
| 5 Seal Washer                                | 16 Latch Spring                            |
| 6 Seal Retaining Ring                        | 17 Latch Shaft Bushing and O-Ring (Qty. 2) |
| 7 Seal Assembly Bolt                         | 18 Diaphragm                               |
| 8 Bolt Seal                                  | 19 Diaphragm Cover                         |
| 9 Clapper Spring                             | 20 Diaphragm Cover Cap Screws (Qty. 8)     |
| 10 Clapper Shaft                             | 21 Latch Shaft                             |
| 11 Clapper Shaft Bushing and O-Ring (Qty. 2) |  |



\* NOTE: The 1½-inch/48.3-mm and 2-inch/60.3-mm valve sizes contain washers under the heads of the cover plate bolts.



# FireLock NXT™ Preaction Valve

SERIES 769

## SECTION VIEW DRAWING AND DESCRIPTION – SERIES 776 LOW-PRESSURE ACTUATOR

The Series 776 Low-Pressure Actuator is located in the trim of Series 769 FireLock NXT Preaction Valves and acts as the trigger for these systems.

Diaphragms separate the low-pressure actuator into three chambers. The upper air chamber controls activation, while the middle and lower chambers act as the water valve.

During setup, system air is applied to the upper chamber of the low-pressure actuator. When the Auto Vent Sleeve of the low-pressure actuator is pulled up, the upper chamber manually sets. Air pressure in the upper chamber holds the Auto Vent closed, while it exerts force on the water seal of the middle chamber.

When the diaphragm charge line is opened, water enters the lower chamber of the low-pressure actuator. Water that enters the low-pressure actuator flows to the middle chamber through the inlet eyelet, which is pressurized by system air pressure in the upper chamber.

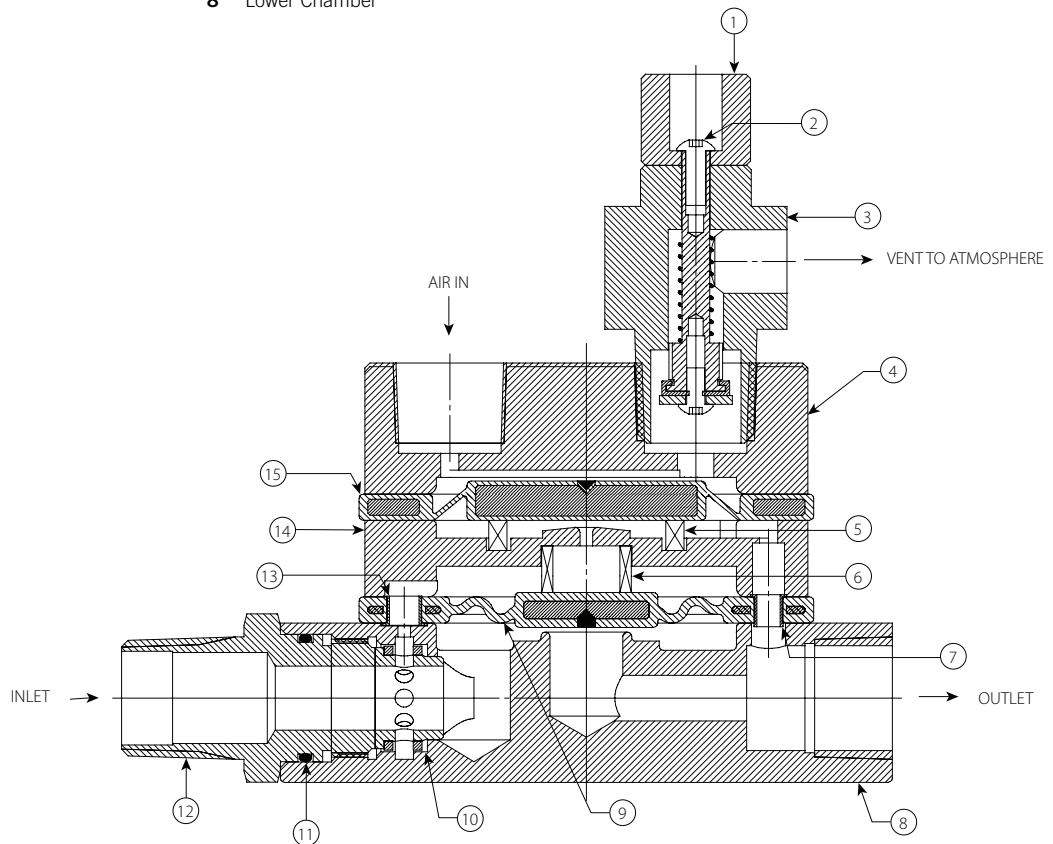
Since the area of the lower diaphragm (exposed to water pressure in the middle chamber) is greater than the area of the lower chamber, the lower chamber seals off. Water does not flow to the outlet of the low-pressure actuator, and the supply water pressure creates the water seal.

When system air pressure decays to 7 psi/48 kPa/0.5 Bar, the force exerted by the compression spring in the Auto Vent is greater than the force exerted by air in the upper chamber. The Auto Vent opens, and all air pressure in the upper chamber evacuates.

The upper diaphragm releases water pressure in the middle chamber of the low-pressure actuator, which allows the lower diaphragm to lift and water to flow from the inlet to the outlet. This flow of water releases pressure from the diaphragm charge line of the Series 769 FireLock NXT Preaction Valve, thus allowing the diaphragm to retract. The clapper opens, and water flows into the sprinkler system.

### Bill of Materials

- |   |                             |    |                               |
|---|-----------------------------|----|-------------------------------|
| 1 | Auto Vent Sleeve            | 9  | Lower Diaphragm Assembly      |
| 2 | Auto Vent Screw             | 10 | Strainer Screen (Replaceable) |
| 3 | Auto Vent Assembly          | 11 | Strainer O-Ring Seal          |
| 4 | Upper Chamber               | 12 | Strainer Assembly             |
| 5 | Upper Diaphragm Wave Spring | 13 | Inlet Eyelet                  |
| 6 | Lower Diaphragm Wave Spring | 14 | Middle Chamber                |
| 7 | Outlet Eyelet               | 15 | Upper Diaphragm Assembly      |
| 8 | Lower Chamber               |    |                               |



# FireLock NXT™ Preaction Valve

SERIES 769

## SECTION VIEW DRAWING AND DESCRIPTION – SERIES 746-LPA DRY ACCELERATOR

The Series 746-LPA Dry Accelerator is a quick-opening device, which exhausts air from the Series 776 Low-Pressure Actuator to speed valve operation.

A diaphragm separates the Series 746-LPA Dry Accelerator into two chambers. The closing chamber contains a compression spring, which maintains the chamber in the closed position. The closed position is maintained as long as the pressure differential between the opening and closing chambers is less than 3 psi/21 kPa/0.2 Bar.

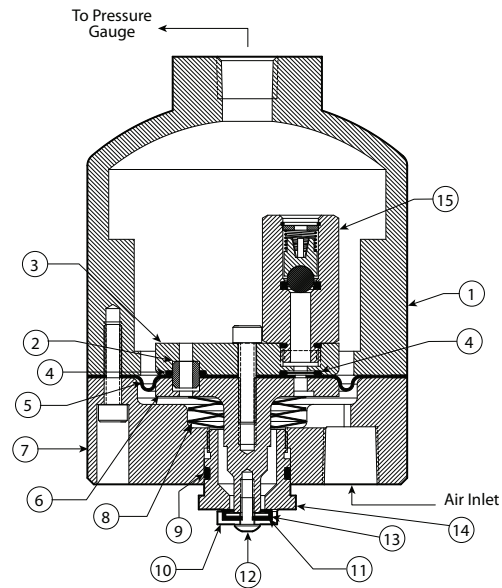
When the system introduces air pressure into the dry accelerator, air enters the closing chamber and passes through a check valve to the opening chamber. The check valve, which allows flow into the opening chamber, prevents pressure from escaping the opening chamber. Therefore, air can escape only through the restrictor.

When a rapid loss of system air pressure occurs, such as an open sprinkler, air escapes from the closing chamber faster than it escapes from the opening chamber. As the sprinkler system's pressure continues to decay, a differential pressure develops across the diaphragm. When this differential pressure reaches 3 – 5 psi/21 – 34 kPa/0.2 – 0.3 Bar, the opening chamber's pressure overcomes the compression spring's closing force, causing the closing chamber to open to the atmosphere. The closing chamber opens immediately and releases pressure from the actuator, resulting in valve operation.

**NOTE:** The Series 746-LPA Dry Accelerator must be used only on systems operating below 30 psi/206 kPa/2.1 Bar of air. If air pressure higher than 30 psi/206 kPa/2.1 Bar is required, the Series 746 Dry Accelerator should be used.

**Bill of Materials**

- |   |                     |    |                       |
|---|---------------------|----|-----------------------|
| 1 | Opening/Air Chamber | 9  | O-Ring                |
| 2 | Restrictor          | 10 | Seal Support          |
| 3 | Piston              | 11 | Closing Chamber Seal  |
| 4 | O-Ring              | 12 | Button-Head Cap Screw |
| 5 | Diaphragm           | 13 | Washer                |
| 6 | Actuator Shaft      | 14 | Adjustable Seat       |
| 7 | Closing Chamber     | 15 | Check Valve           |
| 8 | Compression Spring  |    |                       |



CROSS-SECTION WITH UPPER CHAMBER ROTATED  
45° AND BOLT REMOVED FOR CLARITY

Exaggerated for Clarity



# FireLock NXT™ Preaction Valve

## SERIES 769

### AIR SUPPLY REQUIREMENTS

The required air pressure for Series 769 FireLock NXT Preaction Valves is 13 psi/90 kPa/0.9 Bar minimum, regardless of the system supply water pressure. Normal air pressure should not exceed 18 psi/124 kPa/1.2 Bar. Failure to maintain air pressure within the 13 psi/90 kPa to 18 psi/124 kPa/1.2 Bar range may reduce system operation response time.

Systems with air pressure higher than 18 psi/124 kPa/1.2 Bar may require the addition of a Series 746-LPA Dry Accelerator. **NOTE:** The Series 746-LPA Dry Accelerator must be used only on systems operating below 30 psi/206 kPa/2.1 Bar of air. If air pressure higher than 30 psi/206 kPa/2.1 Bar is required, the Series 746 Dry Accelerator should be used.

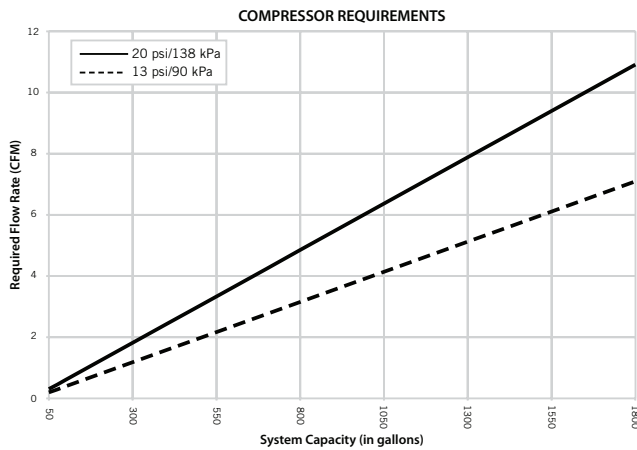
If multiple Series 769 FireLock NXT Preaction Valves are installed with a common air supply, isolate the systems with a spring-loaded, soft-seated ball check valve to ensure air integrity for each system. Good practice is to include a ball valve for isolation and service of each individual system.

Set the air pressure to the required system air pressure. Air pressure differing from the required system air pressure could reduce system operation response time.

The engineer/system designer is responsible for sizing the compressor so that the entire system is charged to the required air pressure within 30 minutes. DO NOT oversize the compressor to provide more airflow. An oversized compressor will slow down or possibly prevent valve operation.

If the compressor fills the system too fast, it may be necessary to restrict the air supply. Restricting the air supply will ensure that air being exhausted from an open sprinkler or manual release valve is not replaced by the air supply system as fast as it is being exhausted.

### COMPRESSOR SIZING



### BASE OR RISER-MOUNTED AIR COMPRESSORS

For base or riser-mounted air compressors, the recommended air pressure of 13 psi/90 kPa/0.9 Bar is the “on” or “low” pressure setting for the compressor. The “off” or “high” pressure setting should be 18 psi/124 kPa/1.2 Bar.

When a base or riser-mounted air compressor supplies air to a Series 769 FireLock NXT Preaction Valve, it is not necessary to install the Victaulic Series 757 Regulated Air Maintenance Trim Assembly (AMTA). In this case, the air line of the compressor connects to the trim at the fitting where the Series 757 Regulated AMTA is normally installed (refer to the applicable trim drawing). If the compressor is not equipped with a pressure switch, the Series 757P Air Maintenance Trim Assembly with Pressure Switch should be installed.

### SHOP AIR OR TANK-MOUNTED AIR COMPRESSORS

In the event a compressor becomes inoperative, a properly sized tank-mounted air compressor provides the greatest protection for systems.

When shop air or a tank-mounted air compressor is used, the Series 757 Regulated AMTA must be installed. The Series 757 Regulated AMTA provides proper air regulation from the air reservoir to the sprinkler system.

For tank-mounted air compressors, the recommended air pressure of 13 psi/90 kPa/0.9 Bar should be used as the set point for the air regulator. The “on” pressure of the compressor should be at least 5 psi/34 kPa/0.3 Bar above the set point of the air regulator.

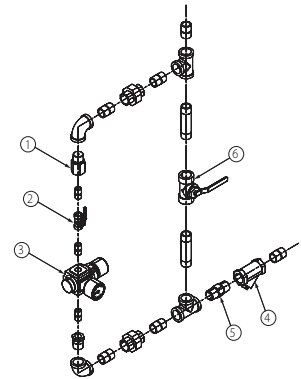
### VICTAULIC SERIES 757 REGULATED AIR MAINTENANCE TRIM ASSEMBLY (AMTA) OPTION

#### NOTICE

- Victaulic recommends a maximum of two Series 769 FireLock NXT Preaction Valves per Series 757 Regulated AMTA.

#### Bill of Materials

- 1 1/8" / 3.2 mm Restrictor
- 2 Slow Fill Ball Valve (Normally Open)
- 3 Air Regulator
- 4 Strainer (100 Mesh)
- 5 Spring-Loaded, Soft-Seated Ball Check Valve
- 6 Fast Fill Ball Valve (Normally Closed)



# FireLock NXT™ Preaction Valve

SERIES 769

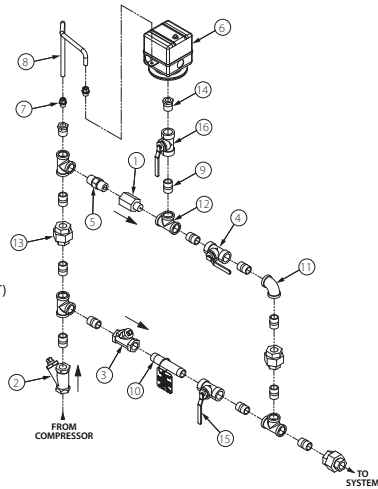
## VICTAULIC SERIES 757P AIR MAINTENANCE TRIM ASSEMBLY (AMTA) WITH PRESSURE SWITCH OPTION

### NOTICE

- Victaulic recommends a maximum of two Series 769 FireLock NXT Preaction Valves per Series 757P AMTA with Pressure Switch.
- Refer to the I-757P Air Maintenance Trim Assembly with Pressure Switch Installation Instructions, supplied with the product, for complete installation, electrical, and pressure switch adjustment information.

**Bill of Materials**

Item	Qty.	Description
1	1	Restrictor (1/2-inch NPT)
2	1	Strainer (1/2-inch NPT)
3	1	Swing Check (1/2-inch NPT)
4	1	Slow-Fill Ball Valve (Normally Open)
5	1	Spring-Loaded, Soft-Seated Check Valve
6	1	Pressure Switch
7	2	Compression Fitting, Straight (1/4-inch NPT x 1/4-inch Tube)
8	1	Copper Tubing (1/4-inch OD)
9	11	Close Nipple (1/2-inch NPT x 1.13)
10	1	Nipple (1/2-inch NPT x 4.00)
11	1	90° Female Elbow (1/2-inch NPT)
12	4	Female Tee (1/2-inch NPT)
13	3	Union (1/2-inch NPT)
14	2	Reducing Bushing (1/2-inch NPT x 1/4-inch NPT)
15	1	Fast-Fill Ball Valve (Normally Closed)
16	1	Pressure Switch Isolation Ball Valve (Normally Open - Lockable)



### COMPRESSOR REQUIREMENTS AND SETTINGS FOR SERIES 769 FIRELOCK NXT PREACTION VALVES INSTALLED WITH SERIES 746-LPA DRY ACCELERATORS

Set the air regulator of the Series 757 Regulated AMTA to a minimum of 13 psi/90 kPa/0.9 Bar.

The Series 757P Air Maintenance Trim Assembly with Pressure Switch **MUST NOT** be used on a Series 769 FireLock NXT Preaction Valve installed with a Series 746-LPA Dry Accelerator, unless a tank and air regulator are added.

In the event a compressor becomes inoperative, a properly sized tank-mounted air compressor provides the greatest protection for systems installed with a Series 746-LPA Dry Accelerator. In this situation, air can be supplied continuously to the sprinkler system for an extended time period. **NOTE:** The Series 757 Regulated AMTA should be used with a tank-mounted air compressor to supply air to a Series 769 FireLock NXT Preaction Valve when the Series 746-LPA Dry Accelerator is used. The use of an air regulator with a base or riser-mounted air compressor could cause short cycling, resulting in premature wear of the compressor.

The air regulator of the Series 757 Regulated AMTA is a relief-type design. Any pressure in the system that is above the set point of the air regulator will be released. Therefore, charging the air regulator above the set point could cause premature operation of a valve installed with a Series 746-LPA Dry Accelerator.

### SETTINGS FOR AIR SUPERVISORY PRESSURE SWITCHES AND ALARM PRESSURE SWITCHES

1. Air supervisory pressure switches are required for preaction systems and must be set according to the following notes. **NOTE:** Switches for Vic-Quick Risers are pre-set at the factory.
  - 1a. Wire the air supervisory pressure switches to activate a low-pressure alarm signal. **NOTE:** In addition, the local authority having jurisdiction may require a high-pressure alarm. Contact the local authority having jurisdiction for this requirement.
  - 1b. Set the air supervisory pressure switches to activate at 2 – 4 psi/14 – 28 kPa/0.1 – 0.3 Bar below the minimum air pressure required (but not lower than 10 psi/69 kPa/0.7 Bar).
  - 1c. Wire the alarm pressure switch to activate a water flow alarm.
  - 1d. Set the alarm pressure switch to activate on a pressure rise of 4 – 8 psi/28 – 55 kPa/0.3 – 0.6 Bar.

### REMOTE SYSTEM TEST VALVE REQUIREMENTS

The remote system test valve (inspector’s test connection) should contain a UL Listed and/or FM Approved valve (normally closed), which can be opened to simulate the operation of a sprinkler.

The remote system test valve (inspector’s test connection) should be located at the most hydraulically demanding location in the release system. **NOTE:** Multiple restrictions on the remote system test valve (inspector’s test connection) may slow the air decay rate and cause the system to respond slower than required.

The remote system test valve (inspector’s test connection) should terminate with an orifice equal to the smallest orifice in the releasing system.

The remote system test valve (inspector’s test connection) is used to ensure that water reaches the most remote part of the system within 60 seconds.

# FireLock NXT™ Preaction Valve

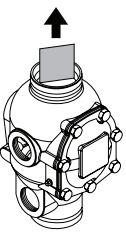
SERIES 769

## IMPORTANT INSTALLATION INFORMATION

- For proper operation and approval, the Series 769 FireLock NXT Preaction Valve must be installed in accordance with the specific trim diagrams included with the shipment. **NOTE:** Victaulic provides specific trim diagrams for installations involving a Series 746-LPA Dry Accelerator.
- Before installing the Series 769 FireLock NXT Preaction Valve, flush the water supply piping thoroughly to remove all foreign material.
- Series 769 FireLock NXT Preaction Valves **MUST NOT** be located in an area where the valve can be exposed to freezing temperatures. In addition, the Series 769 FireLock NXT Preaction Valve **MUST NOT** be located in an area where physical damage may occur.
- It is the system designer's responsibility to confirm material compatibility of the Series 769 FireLock NXT Preaction Valve, trim, and associated accessories when a corrosive environment or contaminated water is present.
- SERIES 769 FIRELOCK NXT PREACTION VALVES MUST BE INSTALLED ONLY IN THE VERTICAL POSITION WITH THE ARROW ON THE BODY POINTING UPWARD.**
- Air or nitrogen supply to the dry piping system must be clean, dry, and oil-free.
- Air supplies must be regulated, restricted, and continuous.
- When an uninterruptible water flow alarm is required, Victaulic recommends the use of a low-pressure alarm installed on the diaphragm charge line downstream of the strainer/check restrictor. Another option is to install a Series 75B Supplemental Alarm Device.
- Per NFPA 13 requirements, piping must be pitched so that systems can drain properly. For areas that are subject to high levels of condensation, or where piping is not properly pitched, an optional Series 75D Water Column Device kit is available to assist in automatically draining water out of the riser.

## VALVE/TRIM INSTALLATION

- Make sure the trim drawing matches the system's requirements.

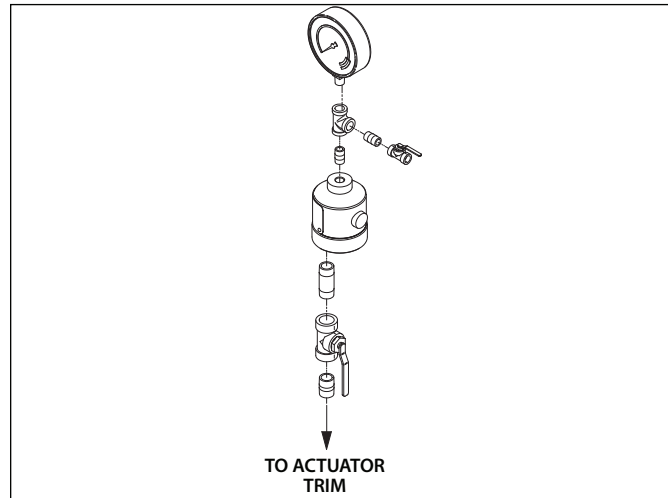
<b>CAUTION</b>	
	<ul style="list-style-type: none"> <li>Make sure the foam spacer is removed from inside the valve body before attempting to install the valve.</li> </ul> <p><b>Failure to follow this instruction could cause improper valve operation, resulting in personal injury and/or property damage.</b></p>

- Remove all plastic caps and foam spacers from the valve.
- Apply a small amount of pipe joint compound or Teflon\* tape to the external threads of all threaded pipe connections. **DO NOT** get any tape, compound, or other foreign material into the valve body, pipe nipples, or valve openings.

\* Teflon is a registered trademark of the DuPont Company

<b>CAUTION</b>
<ul style="list-style-type: none"> <li>Make sure no foreign material gets into the valve body, pipe nipples, or valve openings.</li> <li>If using any material other than Teflon tape, use extra caution so that no material gets into the trim.</li> </ul> <p><b>Failure to follow these instructions could cause improper valve operation, resulting in personal injury and/or property damage.</b></p>

- Install the valve, trim, and accessories per the trim drawing.

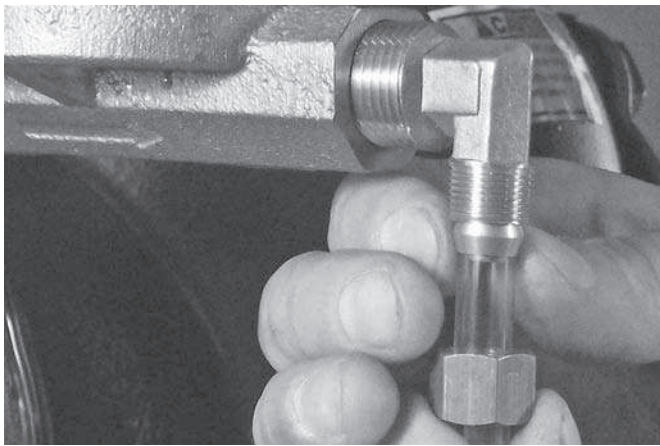
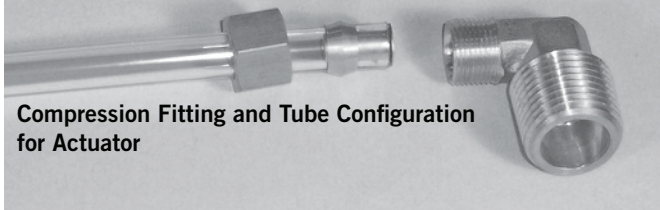
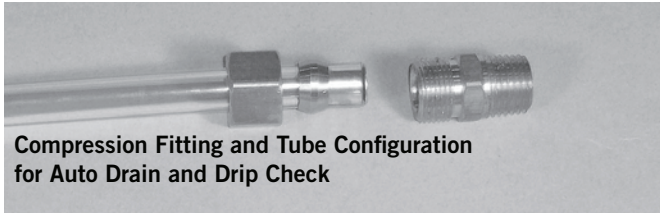


- FOR VALVES INSTALLED WITH A SERIES 746-LPA DRY ACCELERATOR:** Make sure the Series 746-LPA Dry Accelerator is installed in accordance with the trim drawing provided. The end with the vent seal "button" must be installed facing down (toward the trim).
- Supply pressure to the diaphragm charge line by providing an uninterrupted source of water from upstream of the main control valve.

# FireLock NXT™ Preaction Valve



SERIES 769

## COMPRESSION FITTING AND TUBE INSTALLATION



Compression fittings and tubes are provided for connection from the outlet of the auto drain, drip check, and actuator to the drip cup or drain. These compression fittings and tubes must be installed, in accordance with the trim drawing provided. **NEVER** insert a plug into the outlet of the auto drain, drip check, or actuator in place of the compression fitting/tube.

## HYDROSTATIC TESTING

 <b>WARNING</b>	
	<ul style="list-style-type: none"> <li>• If air testing is required, <b>DO NOT</b> exceed 50 psi/345 kPa/3.4 Bar air pressure. Failure to follow this instruction could result in serious personal injury and/or property damage.</li> </ul>

The Victaulic Series 769 FireLock NXT Preaction Valve is UL Listed and FM Approved for a maximum working pressure of 300 psi/2065 kPa/ 20.7 Bar and is factory tested to 600 psi/4135 kPa/41.4 Bar for all sizes. The valve can be hydrostatically tested against the clapper at 200 psi/1380 kPa/13.8 Bar or 50 psi/345 kPa/3.4 Bar above the normal water supply pressure (2-hour limited time period) for acceptance by the authority having jurisdiction.



# FireLock NXT™ Preaction Valve

SERIES 769

## PLACING THE SYSTEM IN SERVICE

- NON-INTERLOCKED, PNEUMATIC RELEASE
- NON-INTERLOCKED PNEUMATIC/ELECTRIC RELEASE
- SINGLE-INTERLOCKED, PNEUMATIC RELEASE
- SINGLE-INTERLOCKED, ELECTRIC RELEASE
- DOUBLE-INTERLOCKED, ELECTRIC (ELECTRIC-PNEUMATIC/ELECTRIC) RELEASE

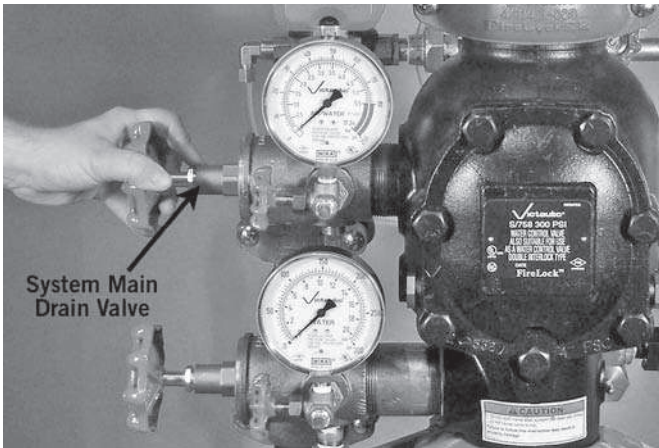
**CAUTION**

- Make sure the Series 769 FireLock NXT Preaction Valve is properly heated and protected from freezing temperatures and physical damage.

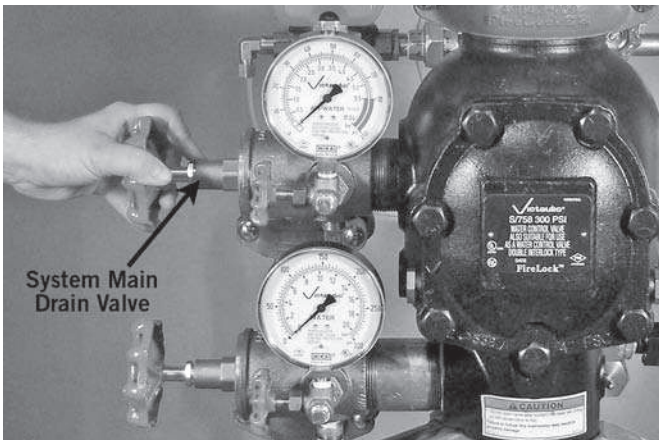
Failure to follow this instruction could cause improper valve operation, resulting in personal injury and/or property damage.

**NOTICE**

- A non-interlocked, pneumatic release system is shown in the photos below.

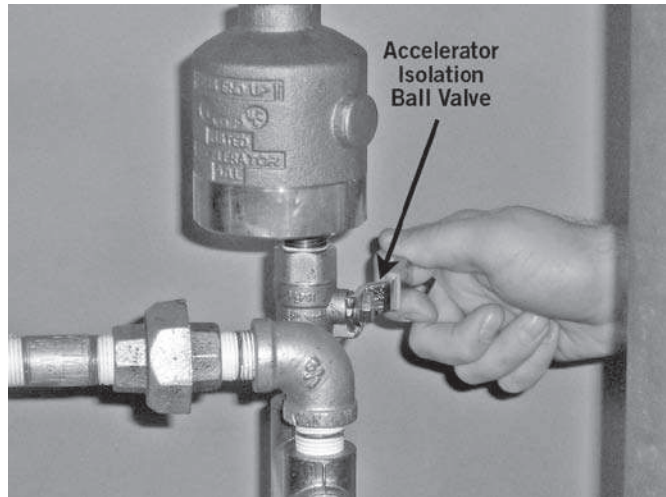


1. Open the system main drain valve. Confirm that the system is drained.

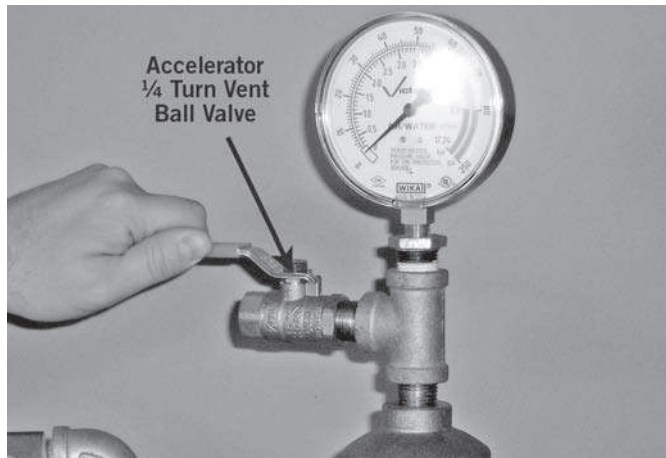


2. Close the system main drain valve.

3. Confirm that all system drains are shut and that the system is free of leaks.
  - 3a. Confirm that the system has been depressurized. The gauges should indicate zero pressure.



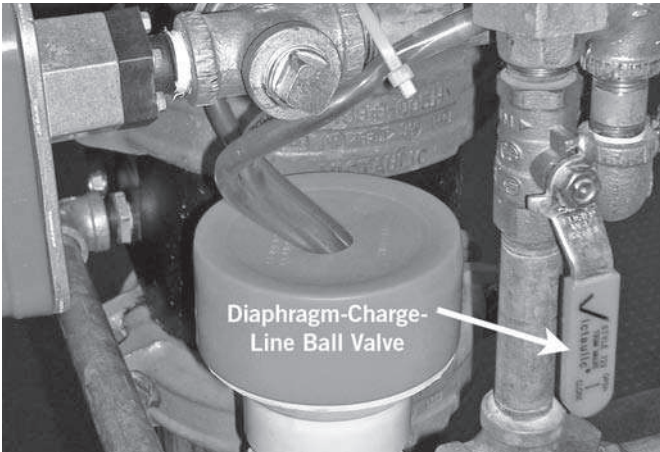
4. **FOR SYSTEMS INSTALLED WITH A SERIES 746-LPA DRY ACCELERATOR:** Confirm that the isolation ball valve to the accelerator is closed.



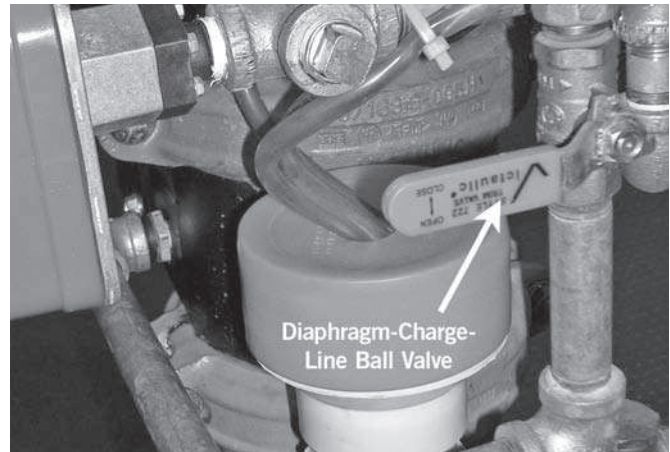
- 4a. **FOR SYSTEMS INSTALLED WITH A SERIES 746-LPA DRY ACCELERATOR:** Open the 1/4-turn vent ball valve.

# FireLock NXT™ Preaction Valve

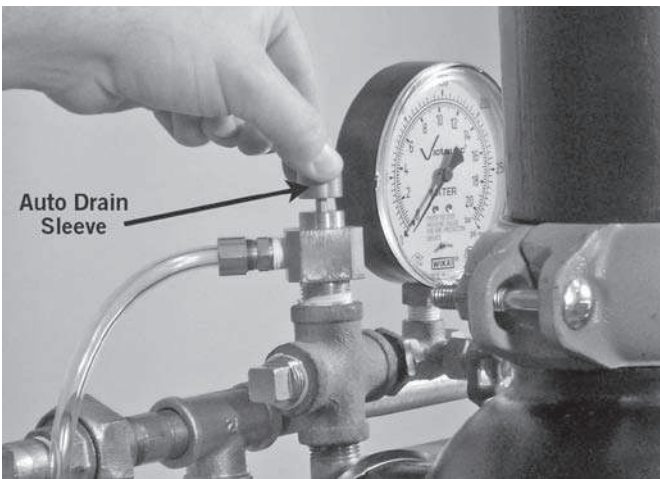
SERIES 769



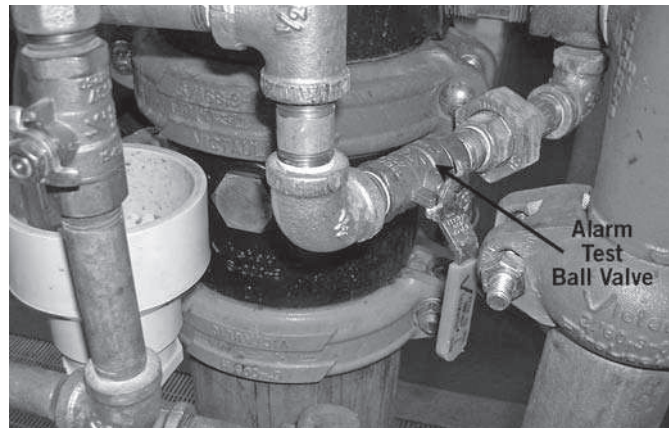
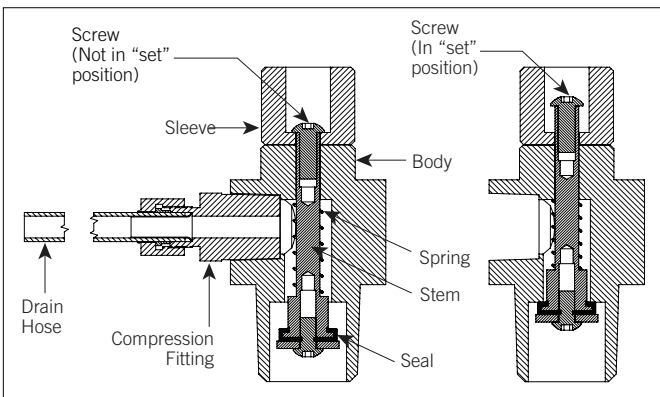
5. Open the diaphragm-charge-line ball valve.



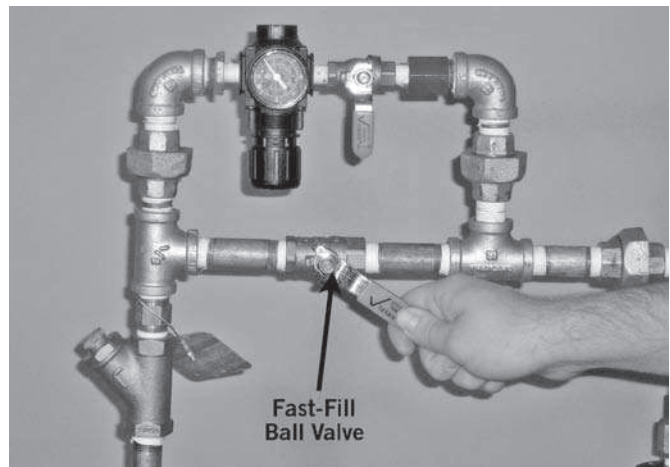
9. Close the diaphragm-charge-line ball valve.



6. Confirm that water is flowing steadily from the Auto Drain. Pull up on the Auto Drain Sleeve.
7. **FOR SYSTEMS INSTALLED WITH A SERIES 776 LOW-PRESSURE ACTUATOR:** Confirm that water is flowing through the Series 776 Low-Pressure Actuator after opening the diaphragm-charge-line ball valve and pulling up on the Auto Drain Sleeve.
8. **FOR SYSTEMS INSTALLED WITH A SERIES 753-E SOLENOID VALVE:** Make sure no water flows through the solenoid after opening the diaphragm-charge-line ball valve. DO NOT pull up on the Auto Drain Sleeve.



10. Confirm that the alarm test ball valve is closed.



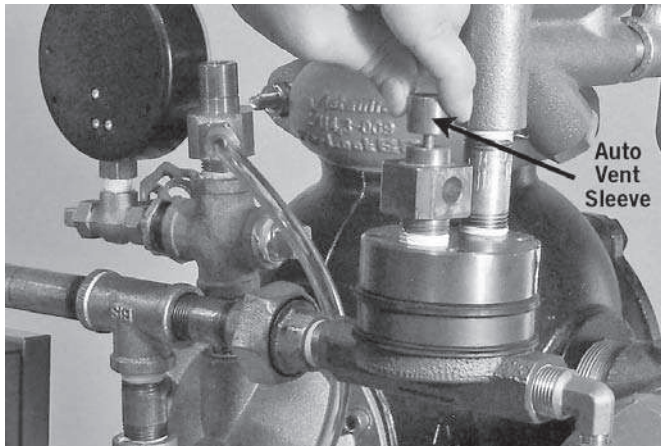
11. Charge the system with air by turning on the compressor or by opening the fast-fill ball valve on the AMTA (fast-fill ball valve is shown above). Charge the system to 13 psi/90 kPa/0.9 Bar minimum. Refer to the "Air Supply Requirements" section.
12. Confirm that the system is charging by observing the air pressure gauge. If the gauge is not showing an increase in air pressure, there is a leak or an opening in the line. Repair any leaks or openings and restart the setup procedures.



# FireLock NXT™ Preaction Valve

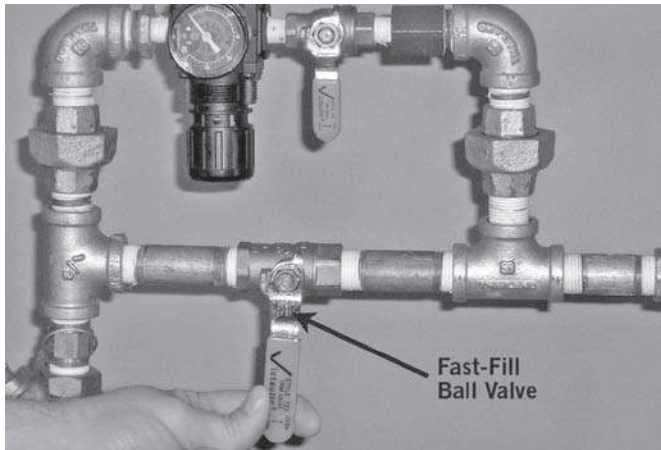
## SERIES 769

13. **FOR SYSTEMS INSTALLED WITH A SERIES 776 LOW-PRESSURE ACTUATOR:** Confirm that no water is being exhausted from the Auto Vent of the Series 776 Low-Pressure Actuator. If water is being exhausted from the Auto Vent, continue to run air through the system in order to remove moisture from the upper chamber of the Series 776 Low-Pressure Actuator. If a Series 746-LPA Dry Accelerator is installed, make sure the accelerator is not flooded.

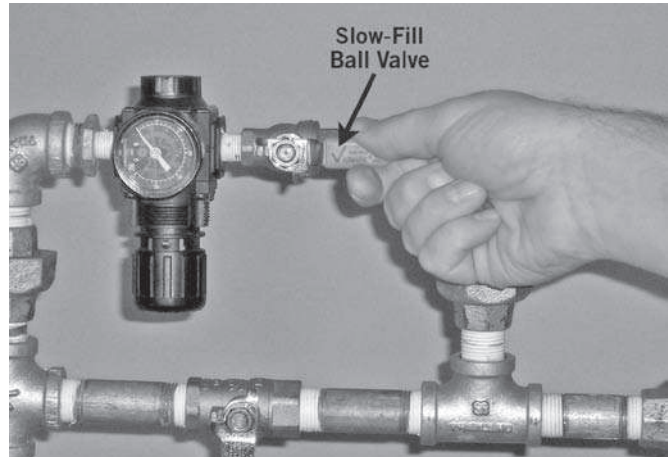


14. **FOR SYSTEMS INSTALLED WITH A SERIES 776 LOW-PRESSURE ACTUATOR:** When the system reaches approximately 10psi/69kPa/0.7 Bar, and no additional moisture is being released from the Auto Vent, pull up on the Auto Vent Sleeve of the Series 776 Low-Pressure Actuator. **NOTE:** The Auto Vent Screw should seal and remain in the set (“UP”) position.

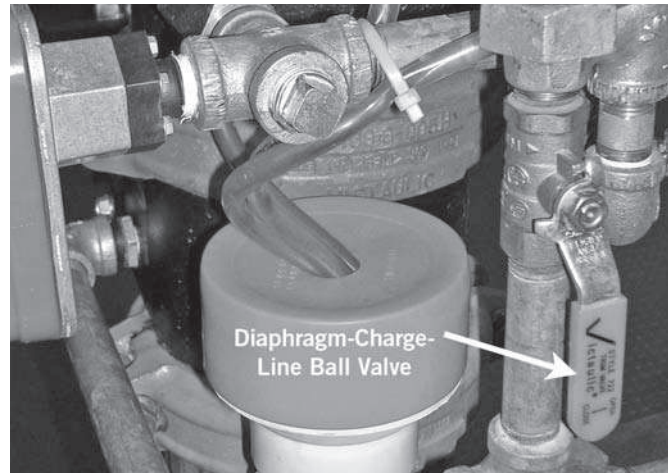
15. **FOR SYSTEMS INSTALLED WITH A SERIES 753-E SOLENOID VALVE:** Confirm that the solenoid is closed.



16. When system air pressure is established, close the fast-fill ball valve on the AMTA.



17. Open the slow-fill ball valve on the AMTA. **NOTE:** Failure to leave the slow-fill ball valve open may allow system pressure to drop, resulting in valve operation in the event of a system leak.



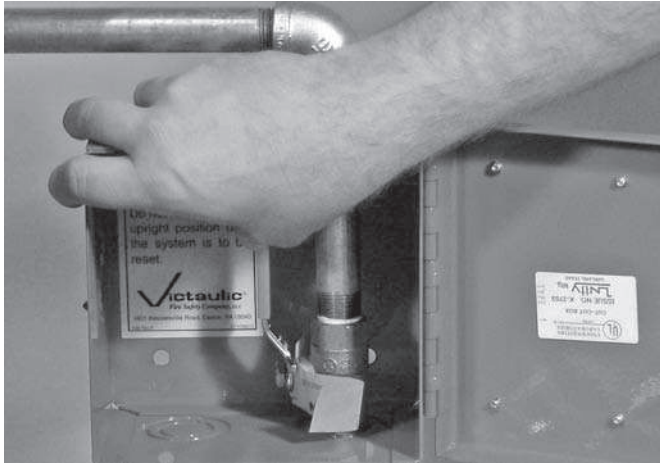
18. Open the diaphragm-charge-line ball valve. Allow water to flow through the Auto Drain tube.



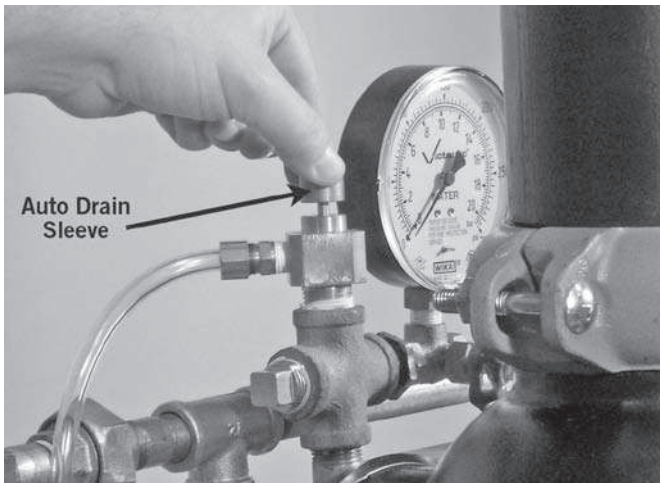
19. Open the manual pull station.

# FireLock NXT™ Preaction Valve

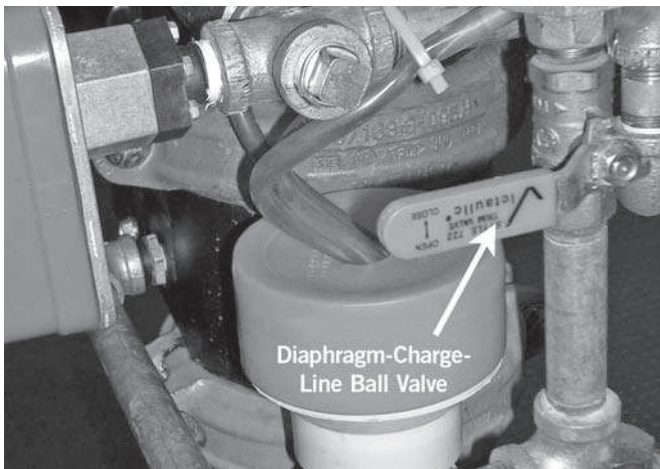
SERIES 769



20. Close the manual pull station.

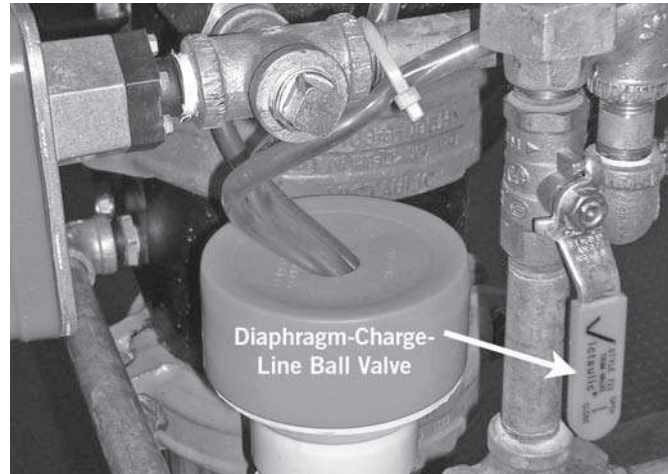


21. Pull up on the Auto Drain Sleeve until the screw is in the set ("UP") position. Verify that there is pressure on the gauge to the diaphragm charge line.

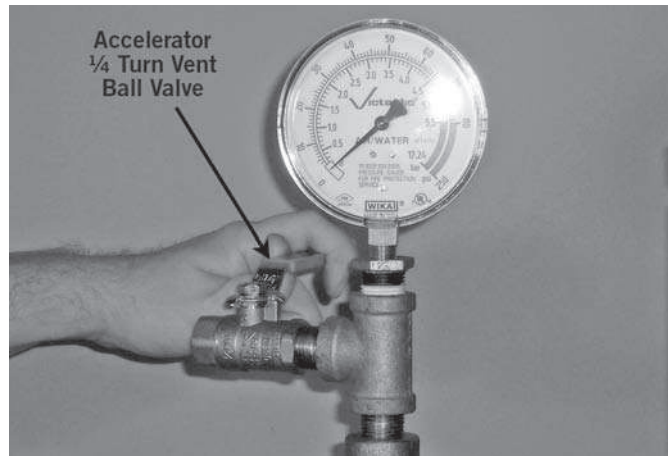


22. When the diaphragm charge line is pressurized, temporarily close the diaphragm-charge-line ball valve. Confirm that the diaphragm charge line is maintaining pressure by observing the diaphragm-charge-line pressure gauge.

22a. If pressure in the diaphragm charge line drops, the diaphragm must be replaced and/or any leaks in the diaphragm charge line must be corrected. Refer to the "Removing and Replacing the Diaphragm Assembly" section.



22b. If pressure in the diaphragm charge line does not drop, re-open the diaphragm-charge-line ball valve, and proceed to the following step.

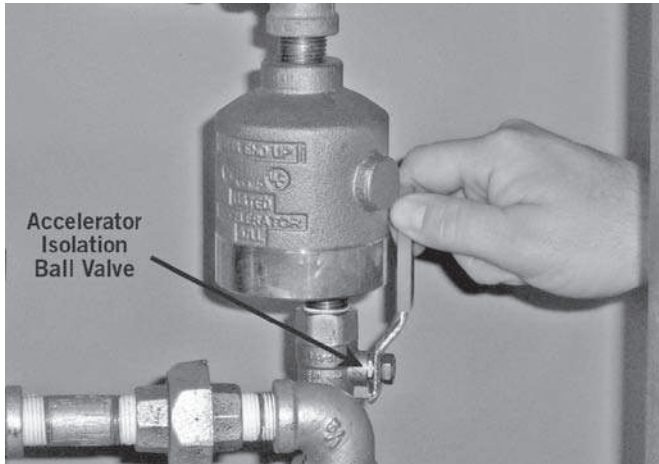


23. **FOR SYSTEMS INSTALLED WITH A SERIES 746-LPA DRY ACCELERATOR:** Close the 1/4-turn vent ball valve on the accelerator.

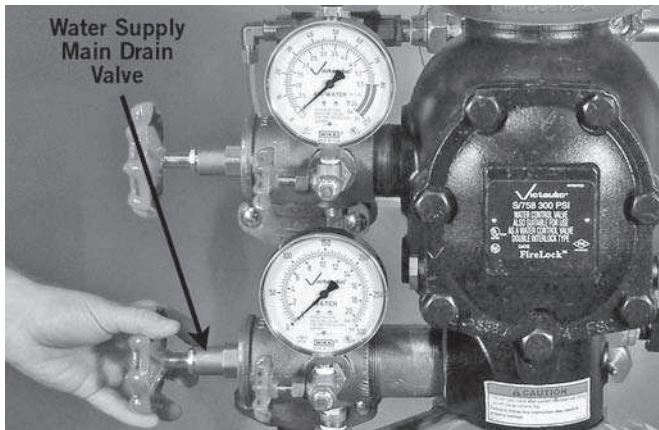


# FireLock NXT™ Preaction Valve

SERIES 769



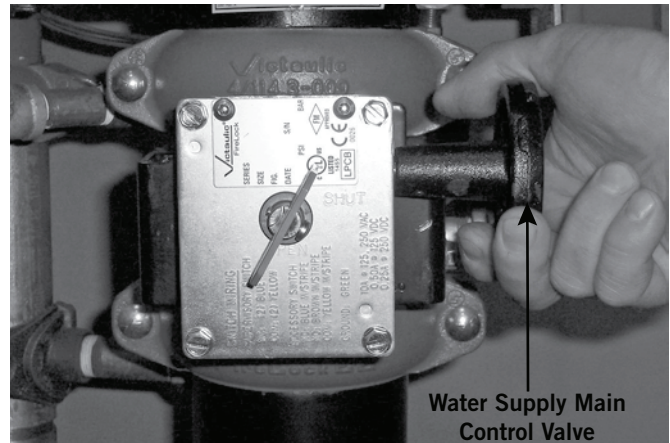
24. **FOR SYSTEMS INSTALLED WITH A SERIES 746-LPA DRY ACCELERATOR:** Open the isolation ball valve. This will set the accelerator
25. Observe the system air pressure over a 24-hour period to confirm system integrity. If there is degradation in system air pressure, find and correct all leaks. **NOTE:** NFPA requires less than 1½-psi/14-kPa/0.1-Bar leakage in 24 hours.



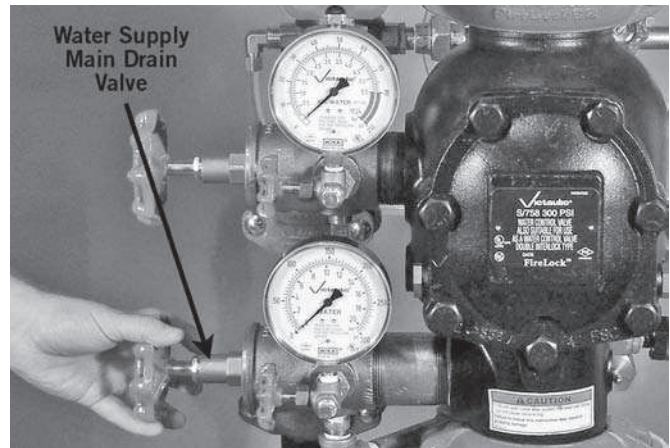
26. Open the water supply main drain valve.

**⚠ CAUTION**

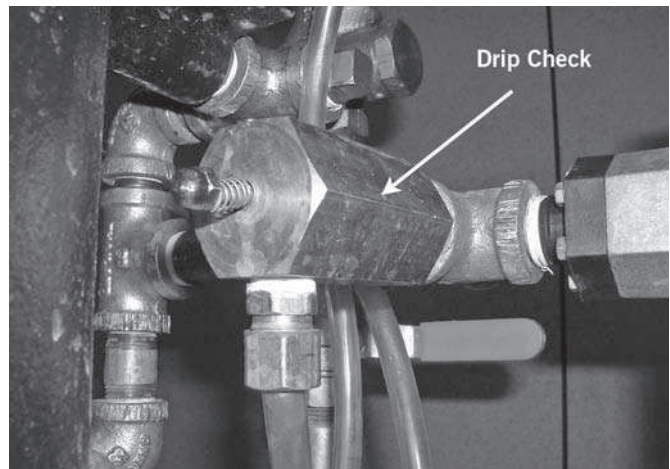
- Take precautions when opening the water supply main control valve, since water will flow from all open system valves. Failure to follow this instruction could result in property damage.



27. Open the water supply main control valve slowly until water flows steadily from the open water supply main drain valve.



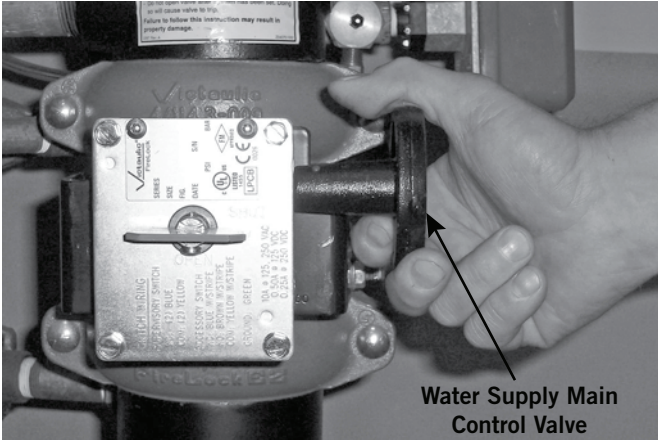
28. Close the water supply main drain valve when a steady flow of water occurs.



29. Confirm that there is no leakage from the intermediate valve chamber. The drip check in the alarm line should not be leaking water or air.

# FireLock NXT™ Preaction Valve

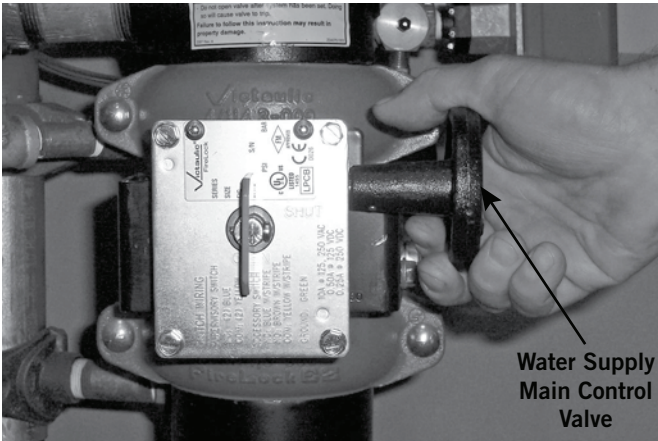
## SERIES 769



Water Supply Main Control Valve

**ON A WEEKLY BASIS, WHEN THE VALVE IS RESET AFTER AN OPERATIONAL TEST (OR AFTER ANY SYSTEM OPERATION):** The main drain valve and any low-point drain valves should be partially opened and then closed to drain water that might be present in the riser. Continue this procedure until all water is released. **NOTE:** The optional Series 75D Water Column Kit can be installed to automate this step.

30. If water is flowing from the drip check, close the water supply 30 control valve, and start over at step 1. Refer to the “Troubleshooting” section.



Water Supply Main Control Valve

31. Open the water supply main control valve fully.
32. Record the system air pressure and the water supply pressure.
33. Confirm that all valves are in their normal operating positions (refer to the table below).

Valve	Normal Operating Position
Diaphragm-Charge-Line Ball Valve	Open
Alarm Test Ball Valve	Closed
Water Supply Main Control Valve	Open
Water Supply Main Drain Valve	Closed
System Main Drain Valve	Closed
Slow-Fill Ball Valve of the Victaulic AMTA (if applicable)	Open
Fast-Fill Ball Valve of the Victaulic AMTA (if applicable)	Closed
Isolation Ball Valve for Series 746-LPA Dry Accelerator (if applicable)	Open
¼-Turn Vent Ball Valve for Series 746-LPA Dry Accelerator (if applicable)	Closed

34. Notify the authority having jurisdiction, remote station alarm monitors, and those in the affected area that the system is in service.

# FireLock NXT™ Preaction Valve

SERIES 769

## EXTERNAL INSPECTION

### WARNING

- The building owner or their representative is responsible for maintaining the fire protection system in proper operating condition.
  - To ensure proper system operation, valves must be inspected in accordance with current NFPA-25 requirements or in accordance with the requirements of the local authority having jurisdiction (whichever is more stringent). Always refer to the instructions in this manual for additional inspection and testing requirements.
  - The frequency of inspections must be increased in the presence of contaminated water supplies, corrosive/scaling water supplies, and corrosive atmospheres.
  - Depressurize and drain the piping system before attempting to install, remove, adjust, or maintain any Victaulic products.
- Failure to follow these instructions could cause system failure, resulting in death, serious personal injury, and property damage.

### NOTICE

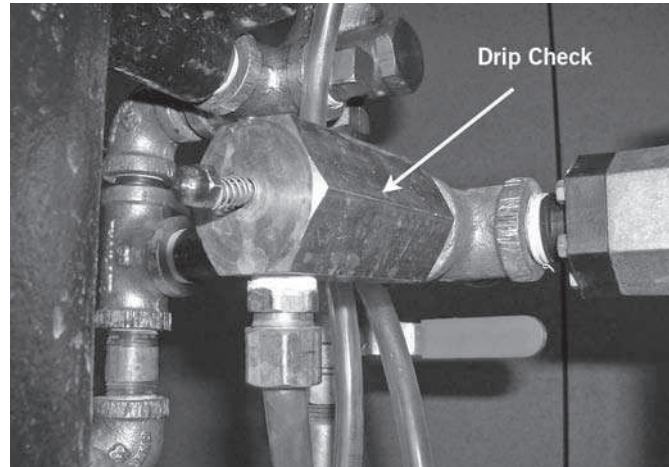
- Any activities that require taking the valve out of service may eliminate the fire protection provided.
- Consideration of a fire patrol should be given for the affected areas.
- Before servicing or testing the system, notify the authority having jurisdiction.

## WEEKLY INSPECTION

1. Perform a visual inspection on the valve and trim on a weekly basis. **NOTE:** If the preaction system is equipped with a low-pressure alarm, monthly inspections may be sufficient. Contact the local authority having jurisdiction for specific requirements.

## MONTHLY INSPECTION

1. Record the system air pressure and water supply pressure. Confirm that the water supply pressure is within the range of normal pressures observed in the area. Significant loss of water supply pressure could indicate an adverse condition in the water supply. Confirm the proper water-to-air ratio is being maintained.



2. Confirm that there is no leakage from the intermediate valve chamber. The drip check in the alarm line should not be leaking water or air.
3. Inspect the valve and trim for mechanical damage and corrosion. Replace any damaged or corroded parts.
4. Confirm that the preaction valve and trim are located in an area that is not subject to freezing temperatures.
5. Confirm that all valves are in their normal operating positions (refer to the table below).

Valve	Normal Operating Position
Diaphragm-Charge-Line Ball Valve	Open
Alarm Test Ball Valve	Closed
Water Supply Main Control Valve	Open
Water Supply Main Drain Valve	Closed
System Main Drain Valve	Closed
Slow-Fill Ball Valve of the Victaulic AMTA (if applicable)	Open
Fast-Fill Ball Valve of the Victaulic AMTA (if applicable)	Closed
Isolation Ball Valve for Series 746-LPA Dry Accelerator (if applicable)	Open
¼-Turn Vent Ball Valve for Series 746-LPA Dry Accelerator (if applicable)	Closed

6. If a Series 746-LPA Dry Accelerator is installed, record the pressure in the air chamber of the dry accelerator. The pressure in the air chamber should equal the system air pressure within the allowable tolerances of the gauges. If the air chamber's pressure is below the system air pressure, follow the "Troubleshooting" section.



# FireLock NXT™ Preaction Valve

SERIES 769

## REQUIRED TESTS

### WARNING

- The building owner or their representative is responsible for maintaining the fire protection system in proper operating condition.
- To ensure proper system operation, valves must be inspected in accordance with current NFPA-25 requirements or in accordance with the requirements of the local authority having jurisdiction (whichever is more stringent). Always refer to the instructions in this manual for additional inspection and testing requirements.
- The frequency of inspections must be increased in the presence of contaminated water supplies, corrosive/scaling water supplies, and corrosive atmospheres.
- Depressurize and drain the piping system before attempting to install, remove, adjust, or maintain any Victaulic products.

Failure to follow these instructions could cause system failure, resulting in death, serious personal injury, and property damage.

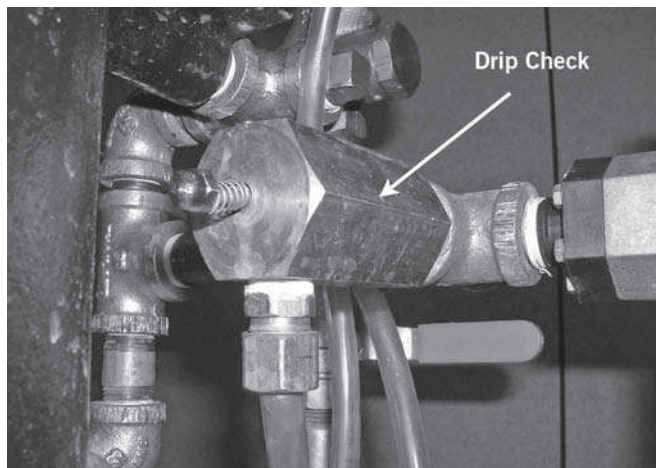
### NOTICE

- Any activities that require taking the valve out of service may eliminate the fire protection provided.
- Consideration of a fire patrol should be given for the affected areas.
- Before servicing or testing the system, notify the authority having jurisdiction.

## MAIN DRAIN TEST

Perform the main drain test on a frequency required by the current NFPA-25 code. The authority having jurisdiction in the area may require these tests on a more frequent basis. Verify these requirements by contacting the authority having jurisdiction in the affected area.

1. Notify the authority having jurisdiction, remote station alarm monitors, and those in the affected area that the main drain test will be performed.
2. Confirm that sufficient drainage is available.
3. Record the water supply pressure and system air pressure.

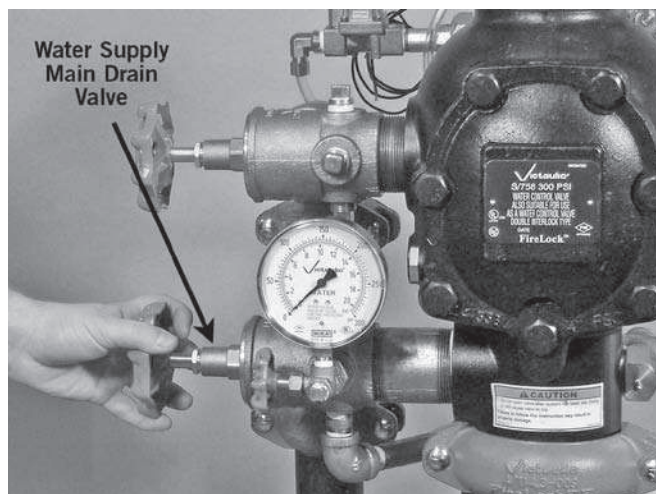


4. Confirm that there is no leakage from the intermediate valve chamber. The drip check in the alarm line should not be leaking water or air.
5. Verify that the system is at the proper air pressure for the local water supply pressure.

### CAUTION

- Use caution to prevent opening the system main drain valve accidentally.

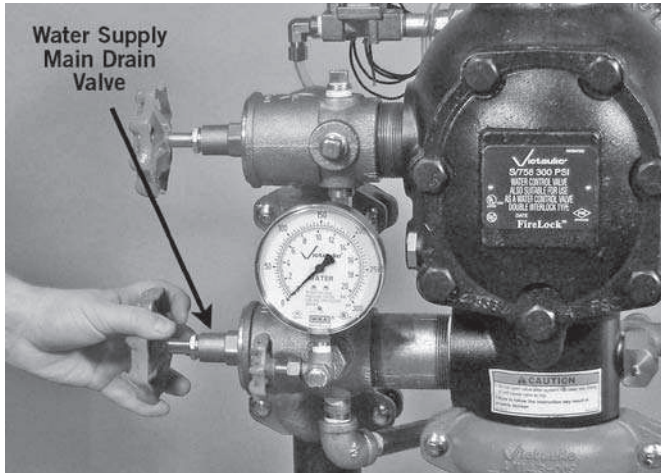
Opening the system main drain valve will cause the valve to operate, resulting in property damage.



6. Open the water supply main drain valve fully to flush the water supply of any contaminants.
7. While the water supply main drain valve is fully open, record the water supply pressure (from the water supply gauge) as the residual pressure.

# FireLock NXT™ Preaction Valve

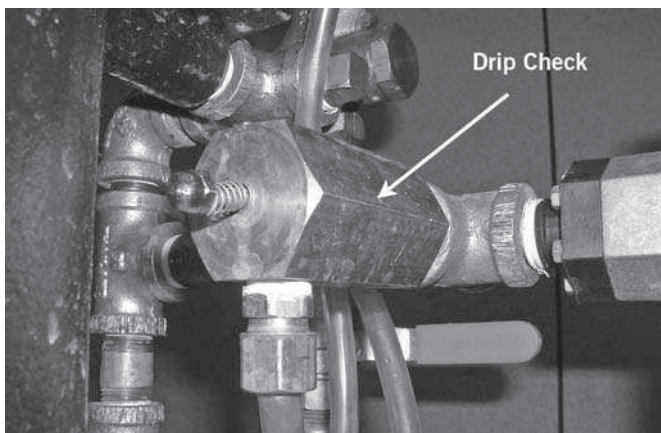
SERIES 769



13. Notify the authority having jurisdiction, remote station alarm monitors, and those in the affected area that the valve is back in service.
14. Provide test results to the authority having jurisdiction, if required.

8. Close the water supply main drain valve slowly.
9. Record the water pressure established after closing the water supply main drain valve.
10. Compare the residual pressure reading, taken above, to the residual pressure readings taken in previous main drain tests. If there is degradation in the residual water supply reading, restore the proper water supply pressure.
11. Confirm that all valves are in their normal operating positions (refer to the table below).

Valve	Normal Operating Position
Diaphragm-Charge-Line Ball Valve	Open
Alarm Test Ball Valve	Closed
Water Supply Main Control Valve	Open
Water Supply Main Drain Valve	Closed
System Main Drain Valve	Closed
Slow-Fill Ball Valve of the Victaulic AMTA (if applicable)	Open
Fast-Fill Ball Valve of the Victaulic AMTA (if applicable)	Closed
Isolation Ball Valve for Series 746-LPA Dry Accelerator (if applicable)	Open
¼-Turn Vent Ball Valve for Series 746-LPA Dry Accelerator (if applicable)	Closed



12. Confirm that there is no leakage from the intermediate valve chamber. The drip check in the alarm line should not be leaking water or air.



# FireLock NXT™ Preaction Valve

SERIES 769

## WATER FLOW ALARM TEST

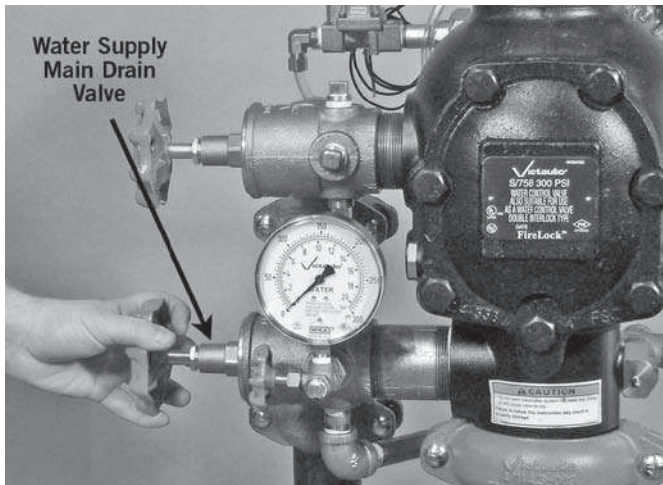
Perform the water flow alarm test on a frequency required by the current NFPA-25 code. The authority having jurisdiction in the area may require these tests on a more frequent basis. Verify these requirements by contacting the authority having jurisdiction in the affected area.

1. Notify the authority having jurisdiction, remote station alarm monitors, and those in the affected area that the water flow alarm test will be performed.

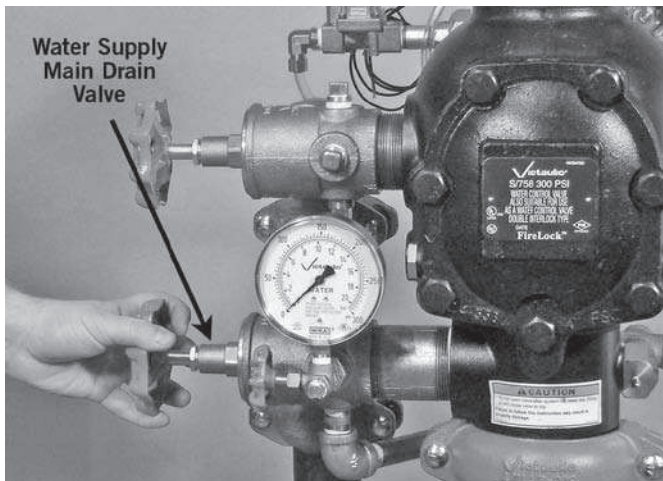
**⚠ CAUTION**

- Use caution to prevent opening the system main drain valve accidentally.

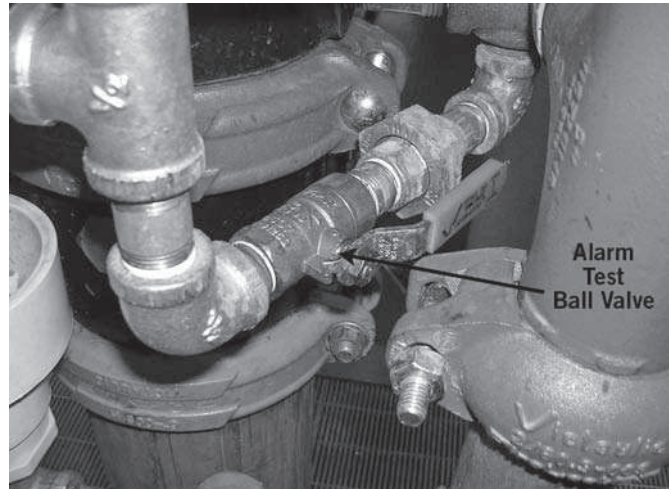
Opening the system main drain valve will cause the valve to operate, resulting in property damage.



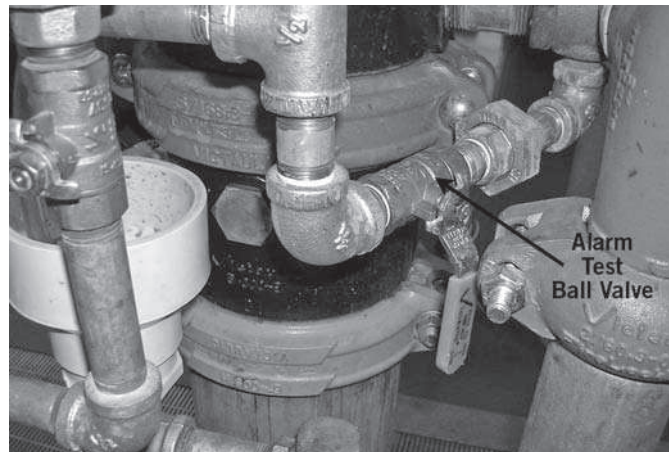
2. Open the water supply main drain valve fully to flush the water supply of any contaminants.



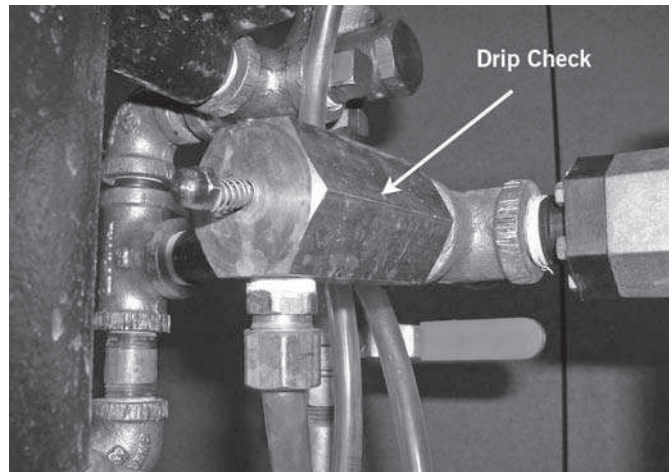
3. Close the water supply main drain valve.



4. Open the alarm test ball valve. Confirm that mechanical and electrical alarms are activated and that remote monitoring stations, if provided, receive an alarm signal.



5. Close the alarm test ball valve after verifying proper operation of all alarms.



6. Push in the plunger of the drip check to verify that there is no pressure in the alarm line.

# FireLock NXT™ Preaction Valve

## SERIES 769

7. Verify that all alarms stopped sounding, that the alarm line drained properly, and that remote station alarms reset properly.
8. Confirm that there is no leakage from the intermediate valve chamber. The drip check in the alarm line should not be leaking water or air.
9. Notify the authority having jurisdiction, remote station alarm monitors, and those in the affected area that the valve is back in service.
10. Provide test results to the authority having jurisdiction, if required.

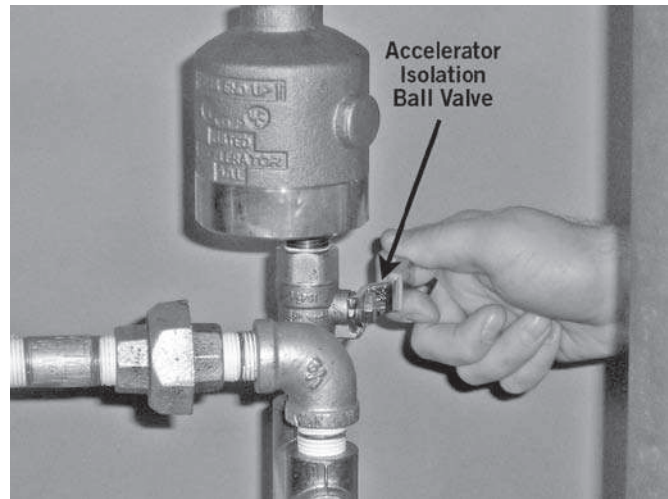
### WATER LEVEL AND LOW AIR ALARM TESTS

Perform the water level and low air alarm tests on a frequency required by the current NFPA-25 code. The authority having jurisdiction in the area may require these tests on a more frequent basis. Verify these requirements by contacting the authority having jurisdiction in the affected area.

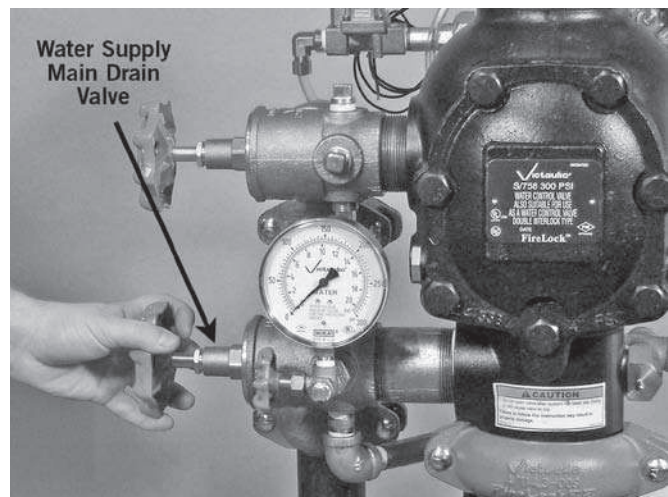
#### NOTICE

- If a Series 746-LPA Dry Accelerator is installed, make sure the authority having jurisdiction is notified that the water level and low air alarm tests are in progress. Failure to close the isolation ball valve of the Series 746-LPA Dry Accelerator may cause the valve to trip, resulting in a false alarm.

1. Notify the authority having jurisdiction, remote station alarm monitors, and those in the affected area that the water level and low air alarm tests will be performed.



2. If a Series 746-LPA Dry Accelerator is installed, close the isolation ball valve.

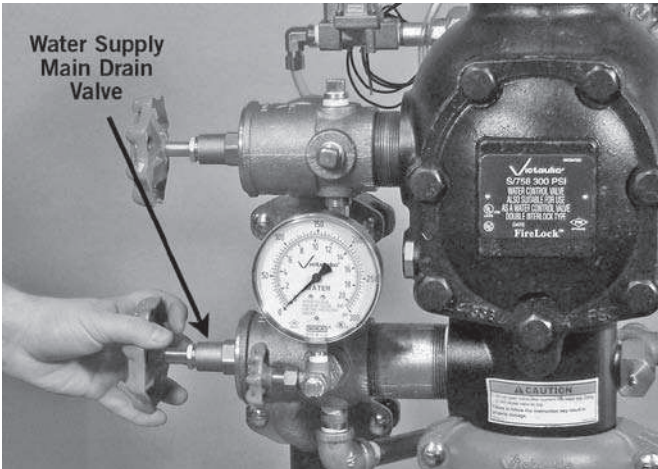


3. Open the water supply main drain valve fully to flush the water supply of any contaminants.

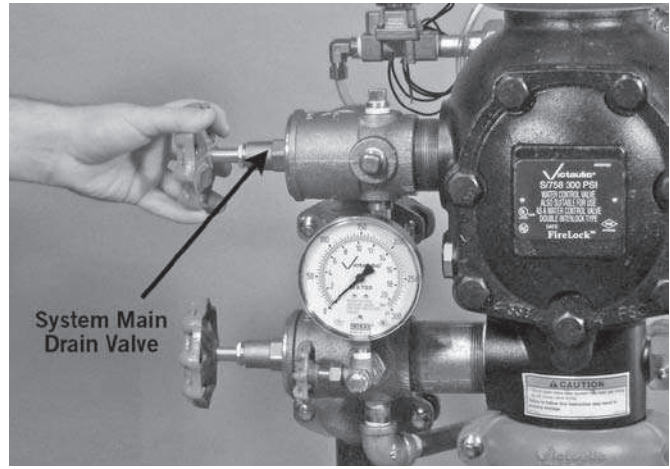


# FireLock NXT™ Preaction Valve

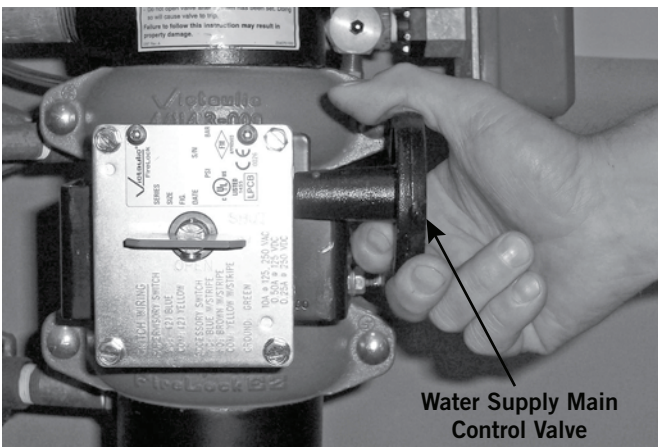
SERIES 769



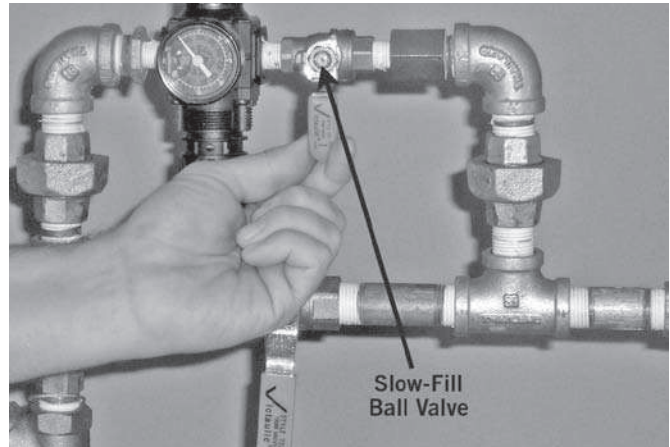
4. Close the water supply main drain valve.



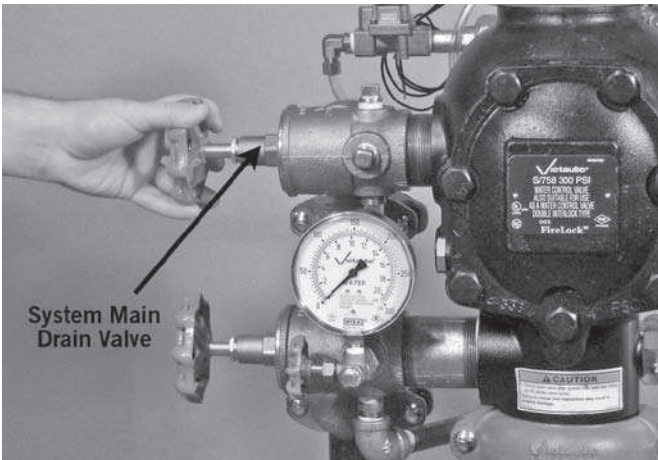
8. Close the system main drain valve.



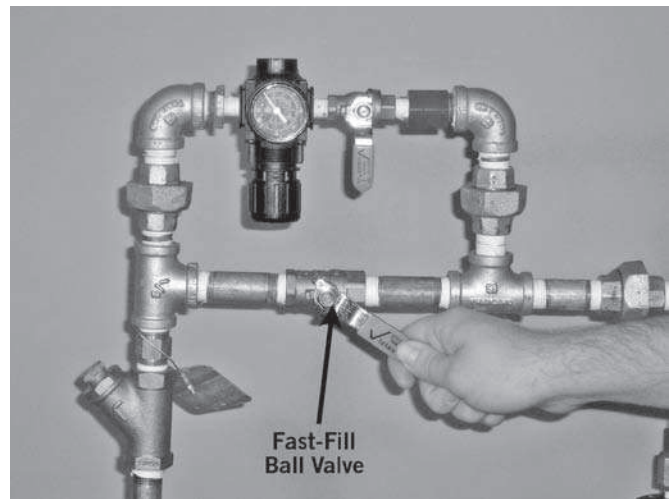
5. Close the water supply main control valve.



9. Close the slow-fill ball valve on the AMTA.



6. Partially open the system main drain valve slowly. Confirm that water is not flowing from the drain. **NOTE:** If water is flowing from the drain, the system may not have drained properly. In this case, follow all steps under the "Placing the System in Service" section.  
7. Record the system air pressure at which the low air alarm activates.

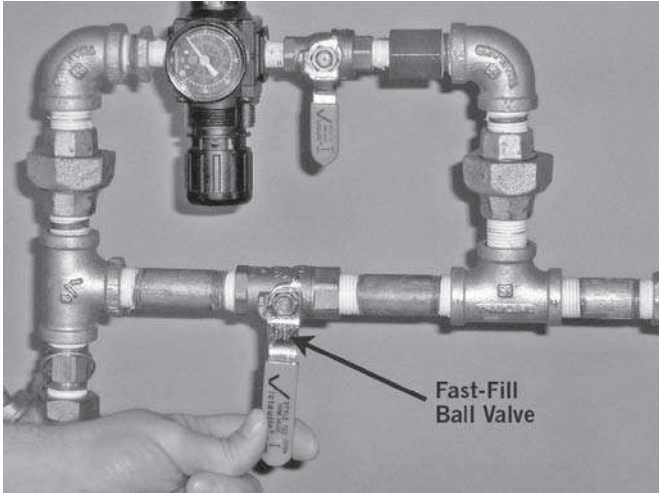


10. Open the fast-fill ball valve on the AMTA. Bring the pressure back up to the normal system pressure.

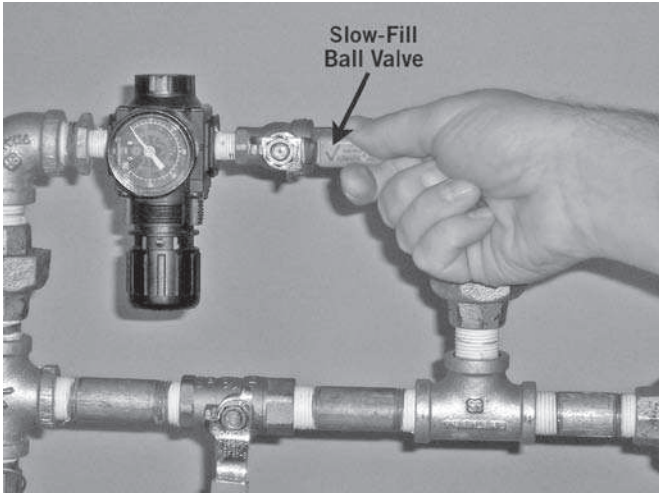


# FireLock NXT™ Preaction Valve

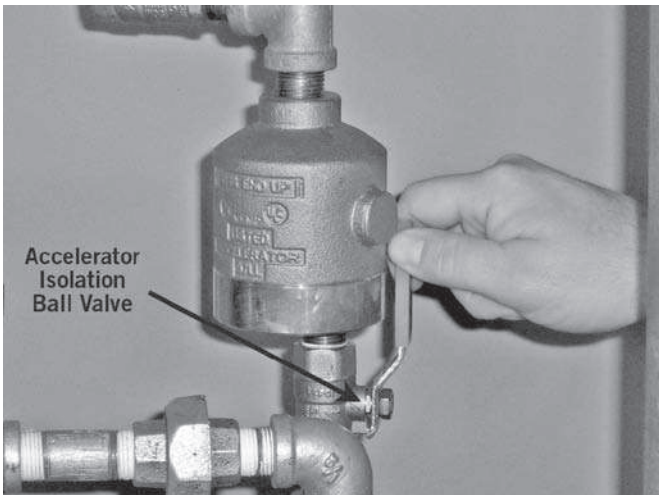
SERIES 769



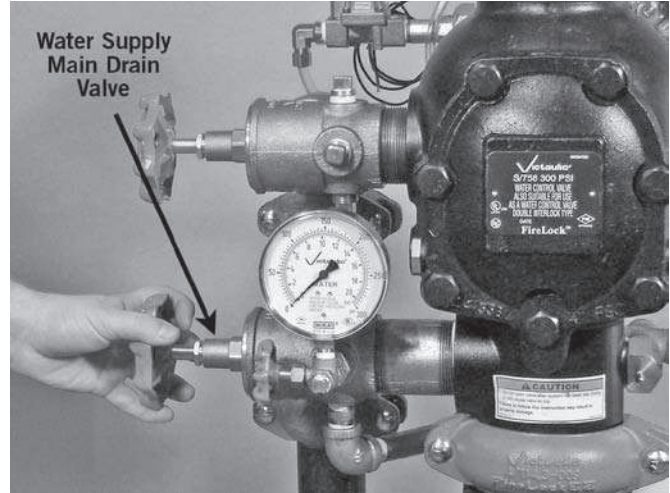
11. When the normal system air pressure is reached, close the fast-fill ball valve on the AMTA.



12. Open the slow-fill ball valve on the AMTA.



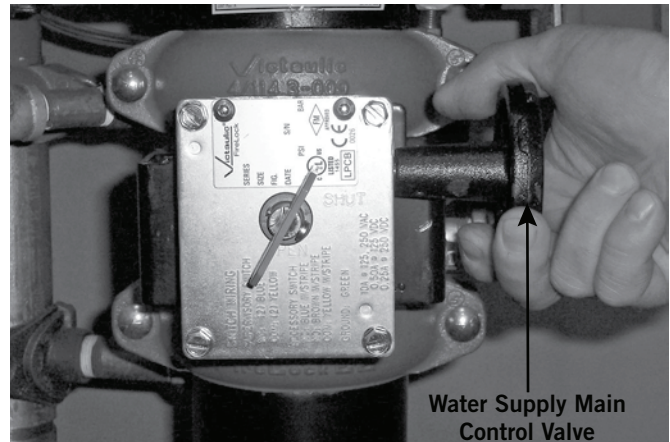
13. If a Series 746-LPA Dry Accelerator is installed, open the isolation ball valve.



14. Open the water supply main drain valve.

**⚠ CAUTION**

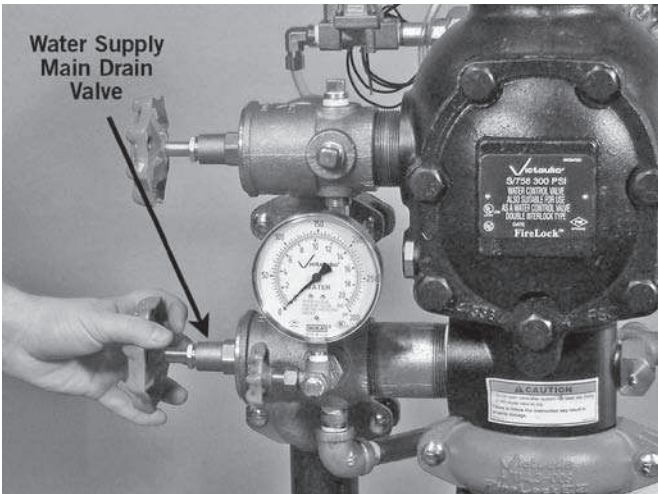
- Take precautions when opening the water supply main control valve, since water will flow from all open system valves. Failure to follow this instruction could result in property damage.



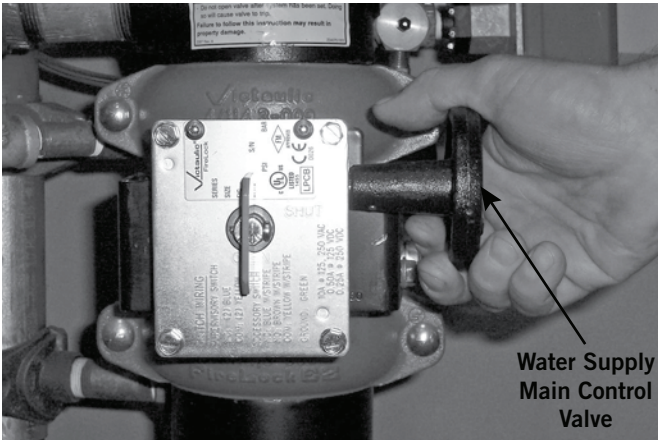
15. Open the water supply main control valve slowly until water flows steadily from the open water supply main drain valve.

# FireLock NXT™ Preaction Valve

SERIES 769



16. Close the water supply main drain valve when a steady flow of water occurs.



17. Open the water supply main control valve fully.
18. Confirm that all valves are in their normal operating positions (refer to the table below).

Valve	Normal Operating Position
Diaphragm-Charge-Line Ball Valve	Open
Alarm Test Ball Valve	Closed
Water Supply Main Control Valve	Open
Water Supply Main Drain Valve	Closed
System Main Drain Valve	Closed
Slow-Fill Ball Valve of the Victaulic AMTA (if applicable)	Open
Fast-Fill Ball Valve of the Victaulic AMTA (if applicable)	Closed
Isolation Ball Valve for Series 746-LPA Dry Accelerator (if applicable)	Open
¼-Turn Vent Ball Valve for Series 746-LPA Dry Accelerator (if applicable)	Closed

19. Notify the authority having jurisdiction, remote station alarm monitors, and those in the affected area that the valve is back in service.
20. Provide test results to the authority having jurisdiction, if required.



# FireLock NXT™ Preaction Valve

SERIES 769

## REQUIRED OPERATIONAL (TRIP) TESTS

### PARTIAL OPERATIONAL (TRIP) TEST

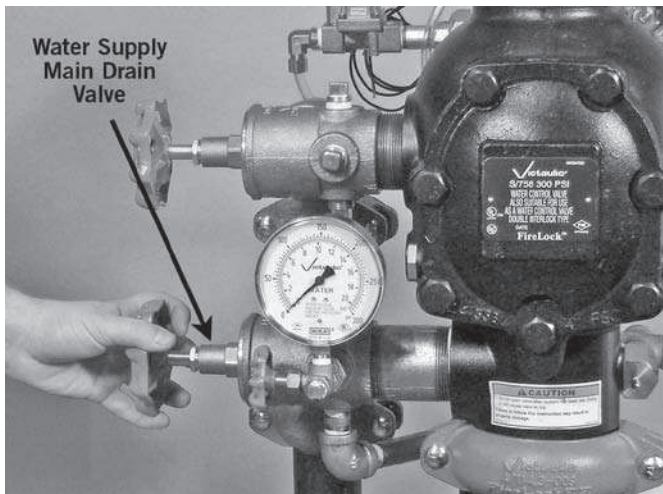
⚠ **WARNING**

- The building owner or their representative is responsible for maintaining the fire protection system in proper operating condition.
- To ensure proper system operation, valves must be inspected in accordance with current NFPA-25 requirements or in accordance with the requirements of the local authority having jurisdiction (whichever is more stringent). Always refer to the instructions in this manual for additional inspection and testing requirements.
- The frequency of inspections must be increased in the presence of contaminated water supplies, corrosive/scaling water supplies, and corrosive atmospheres.
- Depressurize and drain the piping system before attempting to install, remove, adjust, or maintain any Victaulic products.

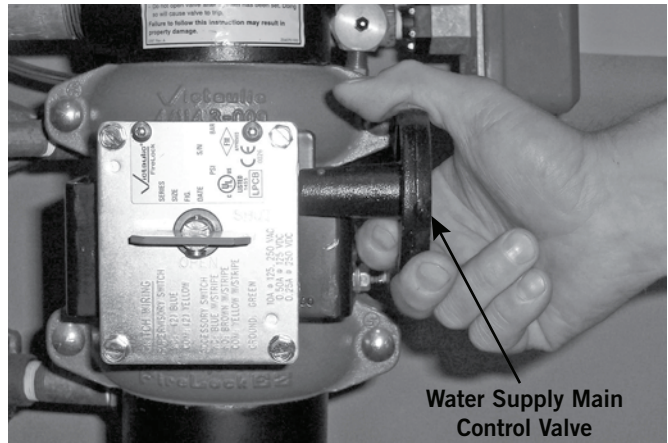
**Failure to follow these instructions could cause system failure, resulting in death, serious personal injury, and property damage.**

Partial operational (trip) tests are required to confirm proper valve operation; however, this test does not confirm full system operation. Victaulic recommends performing the partial operational (trip) test annually (at minimum). **NOTE:** The frequency of the partial operational (trip) test must be increased in the presence of contaminated water supplies, corrosive/scaling water supplies, and corrosive atmospheres. In addition, the authority having jurisdiction in the area may require partial operational (trip) tests on a more frequent basis. Verify these requirements by contacting the authority having jurisdiction in the affected area.

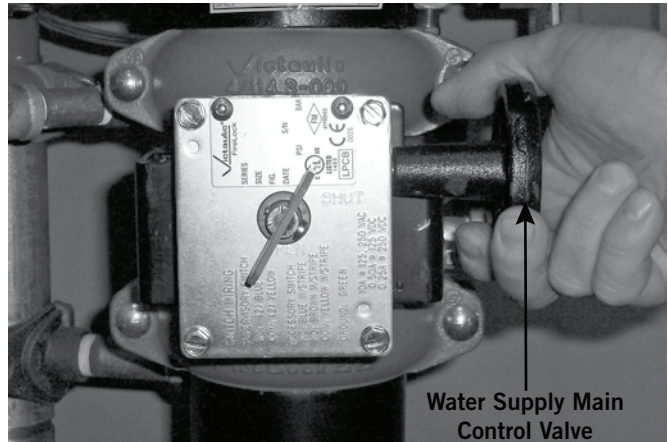
1. Notify the authority having jurisdiction, remote station alarm monitors, and those in the affected area that the partial operational (trip) test will be performed.
2. Record the water supply pressure and system air pressure.



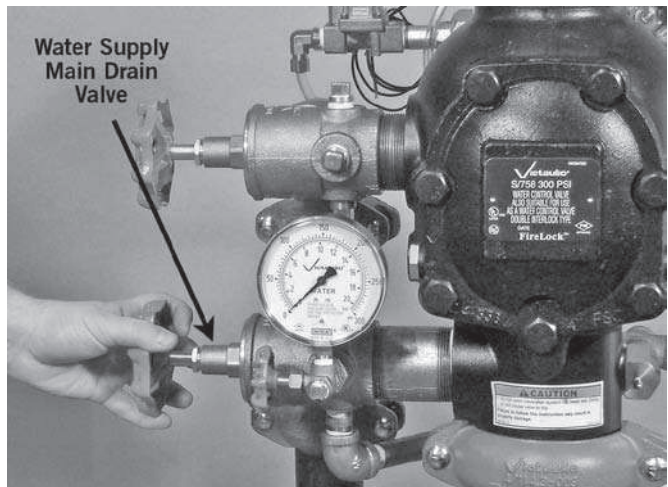
3. Open the water supply main drain valve fully to flush the water supply of any contaminants.



4. Close the water supply main control valve to the point where additional closure will not provide flow through the water supply main drain valve.



5. Open the water supply main control valve slowly until a small amount of water flows through the water supply main drain valve.

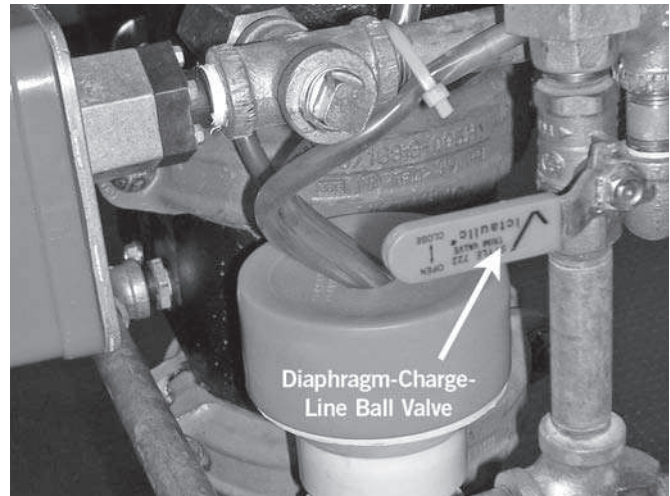
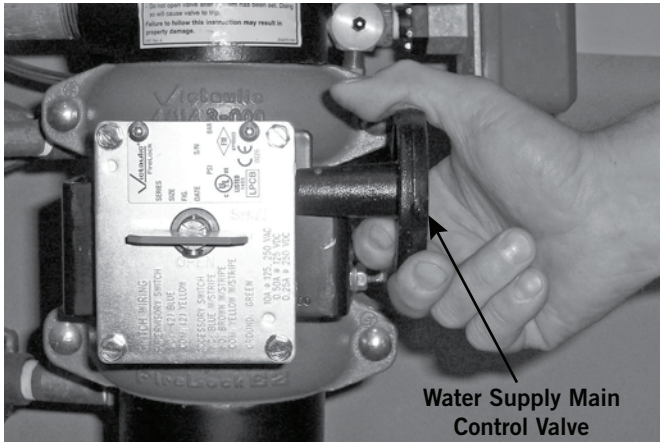


6. Close the water supply main drain valve.

# FireLock NXT™ Preaction Valve

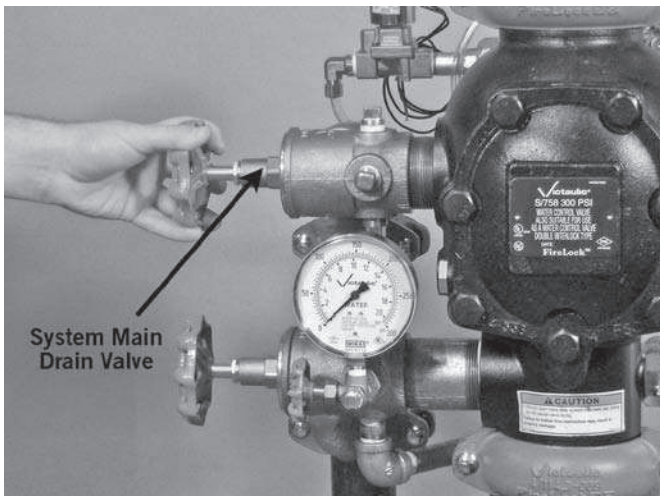
SERIES 769

7. Trip the valve by doing one of the following:
  - a. Energize the solenoid valve
  - b. Relieve the air pressure from the pilot line
  - c. Open the manual pull station
8. Confirm that the diaphragm charge line's pressure drops to zero and that water is flowing through the auto drain to the drip cup.



12. Close the diaphragm-charge-line ball valve.
13. Perform all steps in the "Placing the System in Service" section.

9. Close the water supply main control valve fully.



10. Close the remote system test valve (inspector's test connection) or the system main drain valve. **NOTE:** The system main drain valve is shown above.
11. **SHUT OFF THE AIR SUPPLY.**



# FireLock NXT™ Preaction Valve

SERIES 769

## FULL OPERATIONAL (TRIP) TEST

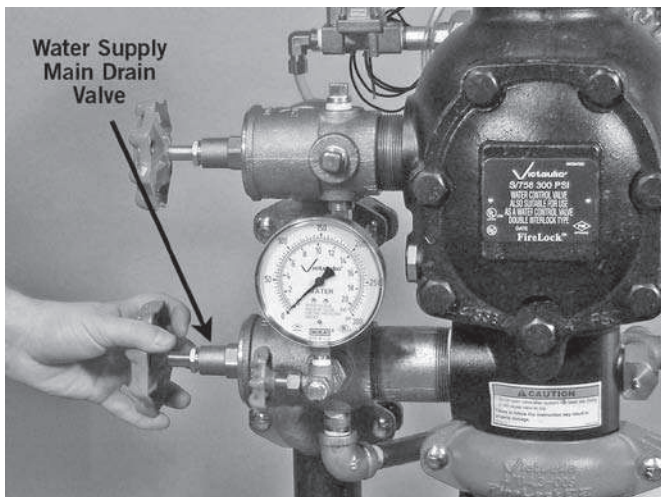
### WARNING

- The building owner or their representative is responsible for maintaining the fire protection system in proper operating condition.
- To ensure proper system operation, valves must be inspected in accordance with current NFPA-25 requirements or in accordance with the requirements of the local authority having jurisdiction (whichever is more stringent). Always refer to the instructions in this manual for additional inspection and testing requirements.
- The frequency of inspections must be increased in the presence of contaminated water supplies, corrosive/scaling water supplies, and corrosive atmospheres.
- Depressurize and drain the piping system before attempting to install, remove, adjust, or maintain any Victaulic products.

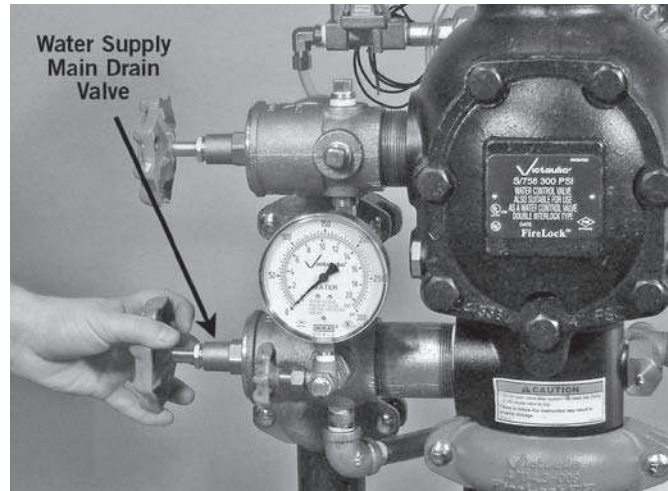
Failure to follow these instructions could cause system failure, resulting in death, serious personal injury, and property damage.

Victaulic recommends the full operational (trip) test every 3 years (at minimum). **NOTE:** The frequency of the full operational (trip) test must be increased in the presence of contaminated water supplies, corrosive/scaling water supplies, and corrosive atmospheres. This test allows a full flow of water into the sprinkler system; therefore, this test must be performed when there is no chance for freezing conditions. In addition, the authority having jurisdiction in the area may require full operational (trip) tests on a more frequent basis. Verify these requirements by contacting the authority having jurisdiction in the affected area.

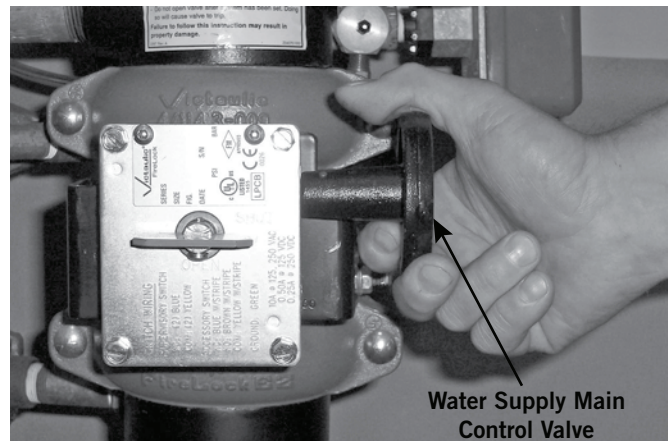
1. Notify the authority having jurisdiction, remote station alarm monitors, and those in the affected area that the full operational (trip) test will be performed.
2. Record the water supply pressure and system air pressure.



3. Open the water supply main drain valve fully to flush the water supply of any contaminants.



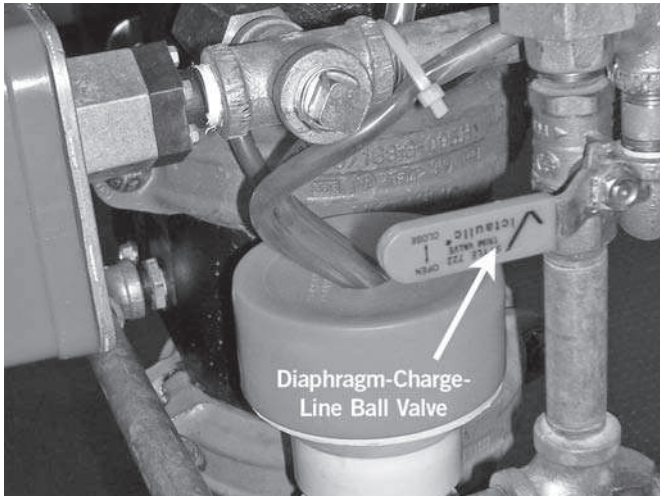
4. Close the water supply main drain valve.
5. Trip the valve by doing one of the following:
  - a. Energize the solenoid valve
  - b. Relieve the air pressure from the pilot line
  - c. Open the manual pull station
6. Record the following:
  - a. Time between opening the remote system test valve (inspector's test connection) to the operation of the preaction valve
  - b. System air pressure when the valve operated
  - c. Time from opening the remote system test valve (inspector's test connection) to when water flows from the test connection's outlet
  - d. All information required by the authority having jurisdiction
7. Confirm that all alarms operate properly.
8. Continue to run water until it is clear.



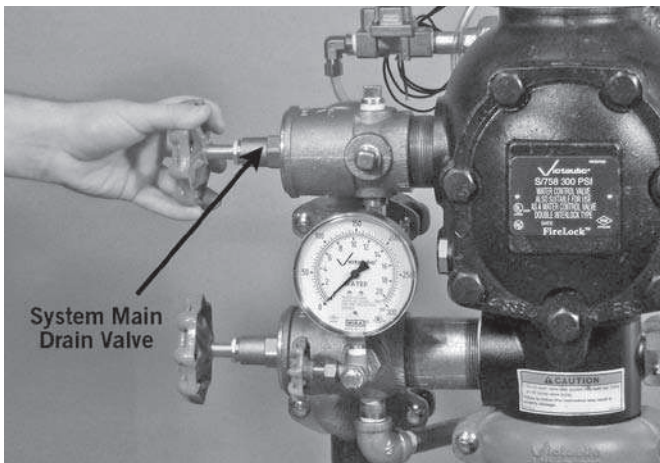
9. Close the water supply main control valve.

# FireLock NXT™ Preaction Valve

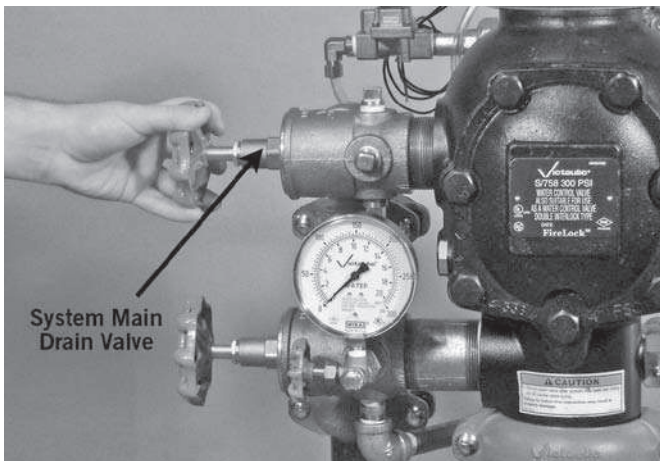
SERIES 769



10. Close the diaphragm-charge-line ball valve.
11. **SHUT OFF THE AIR SUPPLY.**



12. Open the system main drain valve to drain the system.
13. After the system is properly drained, close the remote system test valve (inspector's test connection).



14. Close the system main drain valve.
15. Perform all steps in the "Placing the System in Service" section.





# FireLock NXT™ Preaction Valve

SERIES 769

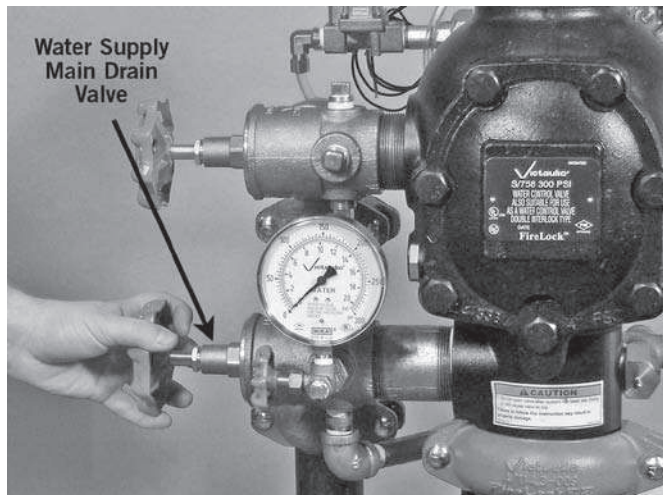
## REQUIRED INTERNAL INSPECTION

Inspect internal components on a frequency required by the current NFPA-25 code. The authority having jurisdiction in the area may require these inspections on a more frequent basis. Verify these requirements by contacting the authority having jurisdiction in the affected area.

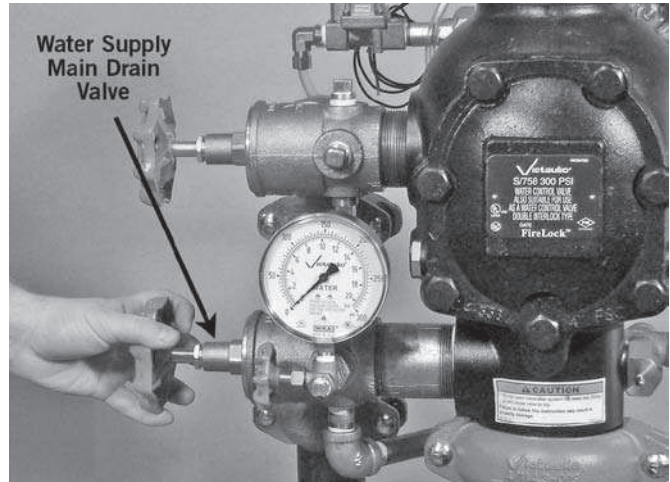
<b>⚠ WARNING</b>	
	<ul style="list-style-type: none"> <li>Depressurize and drain the piping system before attempting to remove the cover plate from the valve.</li> </ul> <p>Failure to follow this instruction could result in serious personal injury and/or property damage.</p>

<b>⚠ CAUTION</b>	
	<ul style="list-style-type: none"> <li>Any activities that require taking the valve out of service may eliminate the fire protection provided.</li> <li>Before servicing or testing the system, notify the authority having jurisdiction.</li> <li>Consideration of a fire patrol should be given in the affected areas.</li> </ul> <p>Failure to follow these instructions could result in serious personal injury and/or property damage.</p>

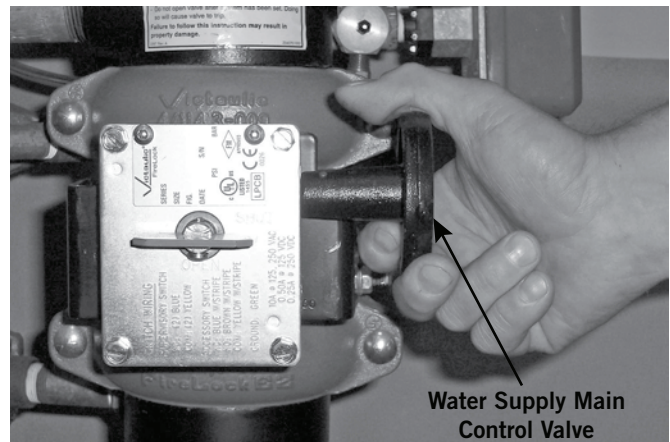
1. Notify the authority having jurisdiction, remote station alarm monitors, and those in the affected area that the system is being taken out of service.



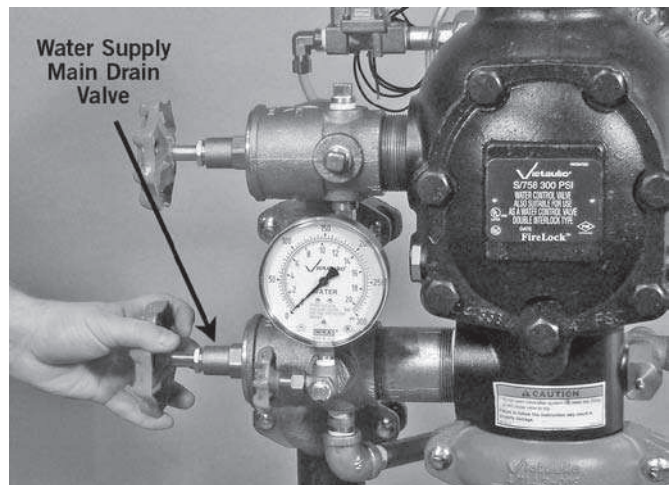
2. Open the water supply main drain valve fully to flush the water supply of any contaminants.



3. Close the water supply main drain valve.



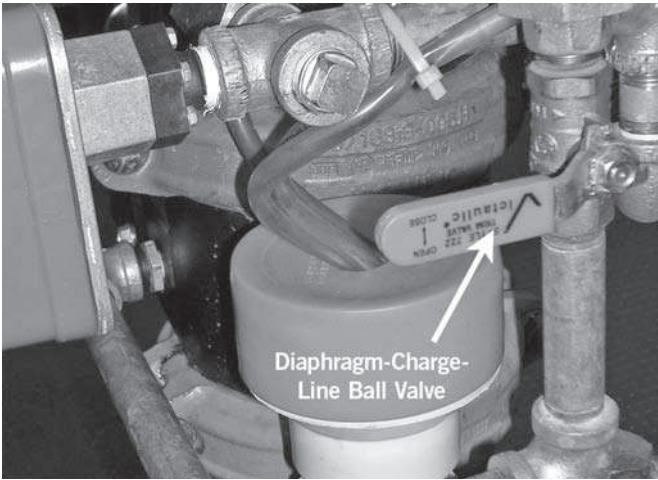
4. Close the water supply main control valve to take the system out of service.



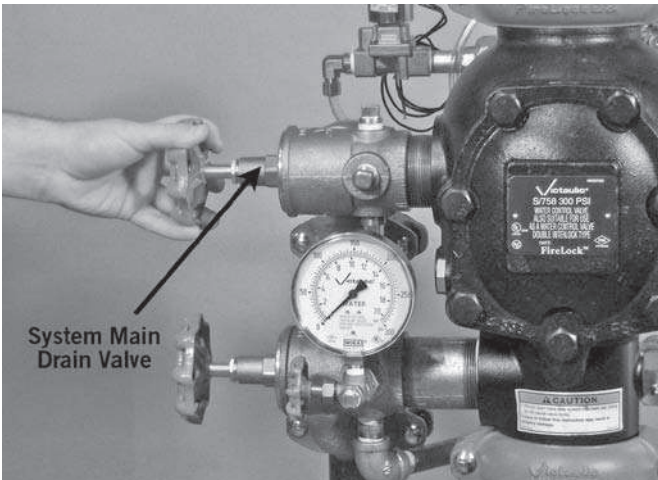
5. Open the water supply main drain valve.
6. Confirm that water is not flowing from the water supply main drain valve.

# FireLock NXT™ Preaction Valve

SERIES 769

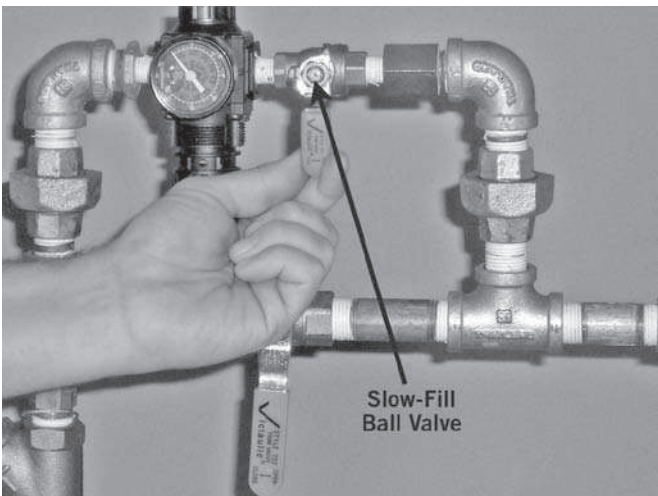


7. Close the diaphragm-charge-line ball valve.



8. Open the system main drain valve to drain any water that has accumulated and to release system air pressure.

**NOTE:** If the system has operated, open the remote system test valve (inspector's test connection) and any auxiliary drain valves.



9. Close the slow-fill ball valve on the AMTA.

## WARNING

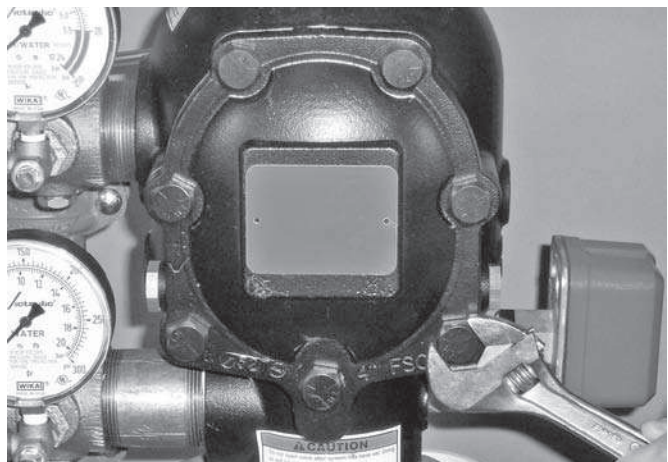


- Make sure the valve is depressurized and drained completely before the cover plate bolts are removed.



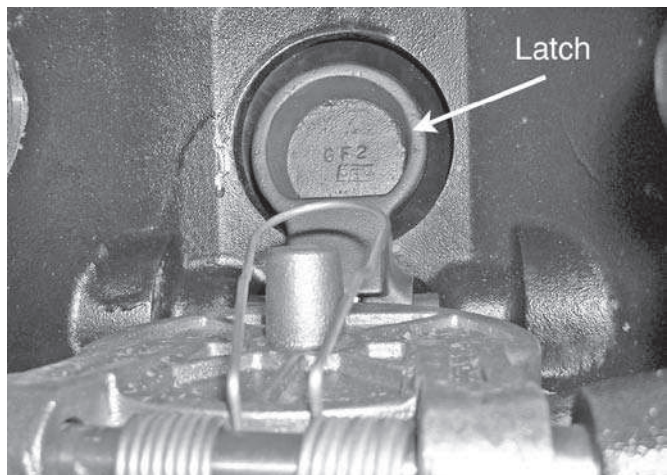
The cover plate could blow off if the cover plate bolts are removed while the valve is pressurized, resulting in serious personal injury and/or property damage.

10. OPEN THE MANUAL PULL STATION.



11. After all pressure is released from the system, loosen the cover plate bolts slowly. **NOTE:** DO NOT remove any cover plate bolts until all cover plate bolts are loosened.

11a. Remove all cover plate bolts, along with the cover plate and cover plate gasket. **NOTE:** The 1 1/2-inch/48.3-mm and 2-inch/60.3-mm valve sizes contain washers under the heads of the cover plate bolts. Keep these washers for re-installation.



12. Push the latch back (toward the diaphragm).



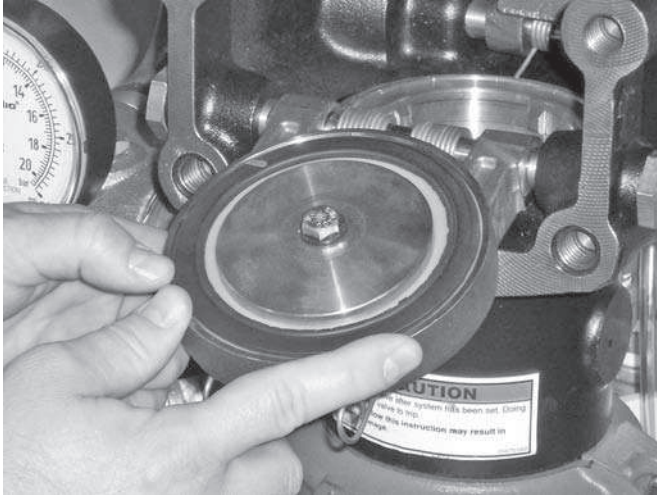
## FireLock NXT™ Preaction Valve

SERIES 769

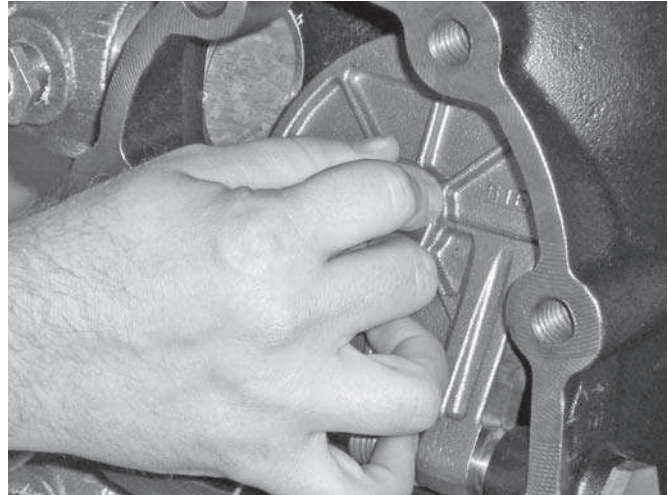
### CAUTION

- **DO NOT** use solvents or abrasives on or near the valve body seat ring.

Failure to follow this instruction could prevent the clapper from sealing, resulting in improper valve operation and/or valve leakage.



13. Rotate the clapper out of the valve body. Inspect the clapper seal and seal-retaining ring. Wipe away any contaminants, dirt, and mineral deposits. Clean out any holes that are plugged in the valve-body seat ring. **DO NOT USE SOLVENTS OR ABRASIVES.**
14. While the clapper is rotated out of the valve body, pull the latch forward to inspect the diaphragm. If the diaphragm shows any signs of wear or damage, replace it with a new, Victaulic-supplied diaphragm. Refer to the "Removing and Replacing the Diaphragm Assembly" section.




15. Inspect the clapper for freedom of movement and physical damage. Replace any damaged or worn parts by following the applicable instructions in the "Maintenance" section.
16. Re-install the cover plate by following the "Installing the Cover Plate Gasket and Cover Plate" section.
17. Place the system back in service by following the "Placing the System in Service" section.


# FireLock NXT™ Preaction Valve

SERIES 769

## MAINTENANCE

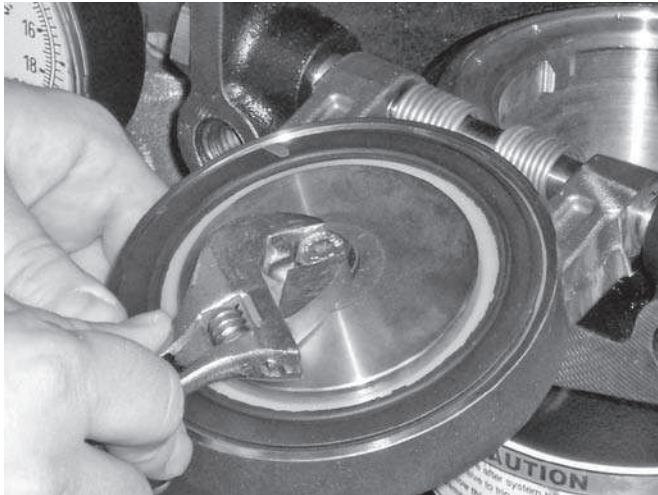
The following sections instruct on how to remove and replace internal valve components. Care must be taken to avoid damage to parts during removal and installation.

<b>⚠ WARNING</b>	
	<ul style="list-style-type: none"> <li>• Depressurize and drain the piping system before attempting to remove the cover plate from the valve.</li> </ul> <p>Failure to follow this instruction could result in serious personal injury and/or property damage.</p>

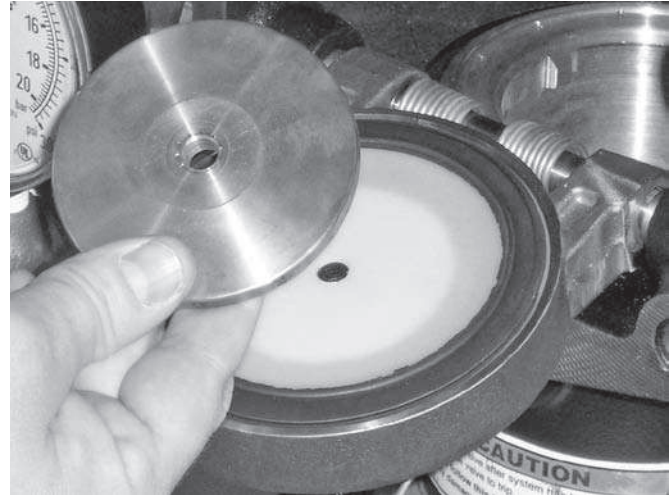
<b>⚠ CAUTION</b>	
	<ul style="list-style-type: none"> <li>• Any activities that require taking the valve out of service may eliminate the fire protection provided.</li> <li>• Before servicing or testing the system, notify the authority having jurisdiction.</li> <li>• Consideration of a fire patrol should be given in the affected areas.</li> </ul> <p>Failure to follow these instructions could result in serious personal injury and/or property damage.</p>

### REMOVING AND REPLACING THE CLAPPER SEAL

1. Perform steps 1 – 12 of the “Required Internal Inspection” section.

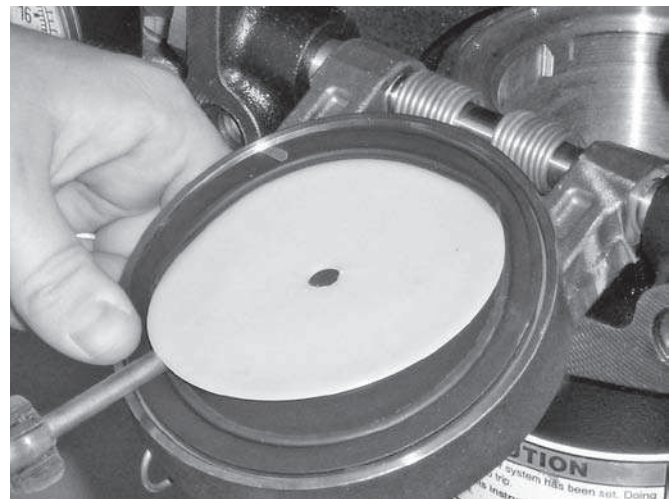


2. Remove the seal assembly bolt/bolt seal from the clapper seal.



3. Remove the seal-retaining ring.

<b>⚠ CAUTION</b>	
<ul style="list-style-type: none"> <li>• <b>DO NOT</b> pry the seal washer out of the clapper seal from the inner hole.</li> </ul> <p>Failure to follow this instruction could damage the seal washer, resulting in improper clapper sealing and valve leakage.</p>	

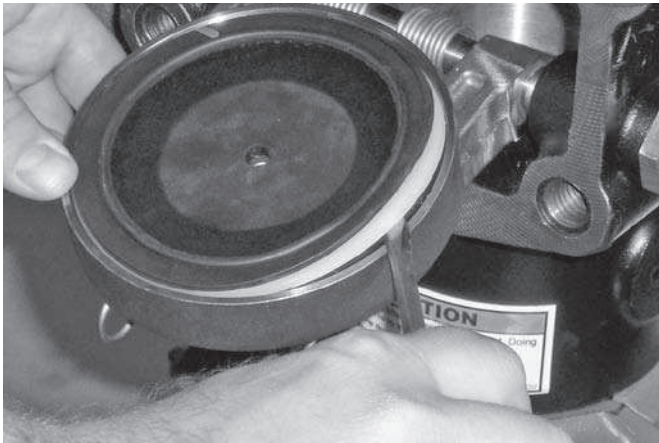


4. Pry the edge of the seal washer from inside the clapper seal, as shown above. **DO NOT PRY THE SEAL WASHER OUT FROM THE INNER HOLE.**
5. Remove the seal washer from the clapper seal. Dry up any moisture that is under the seal washer and on the clapper seal.

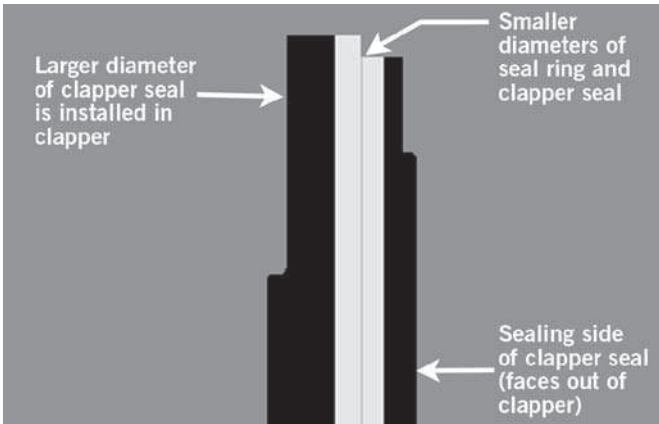
<b>⚠ CAUTION</b>	
<ul style="list-style-type: none"> <li>• Use only Victaulic-supplied replacement parts.</li> </ul> <p>Failure to follow this instruction could cause improper valve operation, resulting in property damage.</p>	

# FireLock NXT™ Preaction Valve

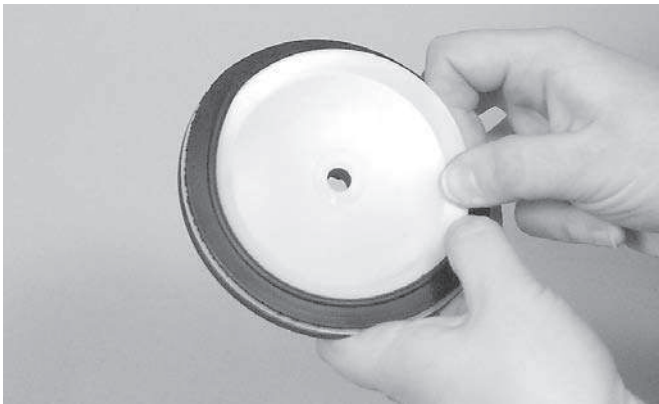
SERIES 769



6. Pry the clapper seal, along with the seal ring, out of the clapper. Inspect the clapper seal. If the clapper seal is torn or worn, replace it with a new, Victaulic-supplied clapper seal. If replacing the clapper seal assembly with a new assembly, skip to step 7.



- 6a. **If using the same clapper seal assembly and the seal ring was removed from the clapper seal in the previous step:** Re-insert the seal ring carefully underneath the outer lip of the clapper seal. Make sure the smaller diameter of the seal ring is toward the sealing surface of the clapper seal.



7. Insert the seal washer carefully underneath the sealing lip of the gasket.
8. Remove any contaminants, dirt, and mineral deposits from the clapper.



9. Install the clapper seal into the clapper carefully. Make sure the seal ring snaps into the clapper completely.

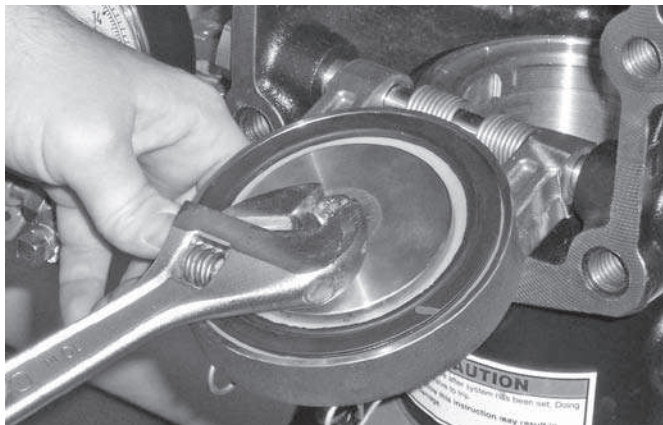


10. Place the seal-retaining ring onto the seal washer of the clapper seal. Install the seal-assembly bolt/bolt seal through the seal-retaining ring and clapper.



# FireLock NXT™ Preaction Valve

SERIES 769



11. Tighten the seal-assembly bolt/bolt seal to the torque value, listed in the table below, to ensure a proper seal.

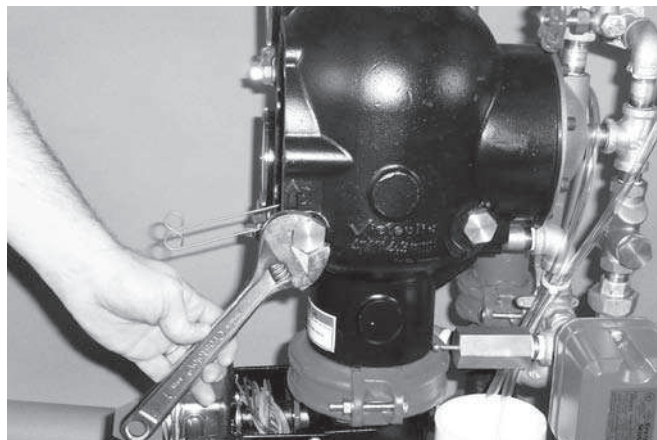
### REQUIRED SEAL-ASSEMBLY BOLT/BOLT SEAL TORQUES

Size		Torque
Nominal Size inches	Actual Outside Diameter inches mm	inch-lbs N•m
1 ½	1.900 48.3	40 5
2	2.375 60.3	40 5
2 ½	2.875 73.0	90 10
76.1 mm	3.000 76.1	90 10
3	3.500 88.9	90 10
4	4.500 114.3	110 12
165.1 mm	6.500 165.1	160 18
6	6.625 168.3	160 18
8	8.625 219.1	160 18

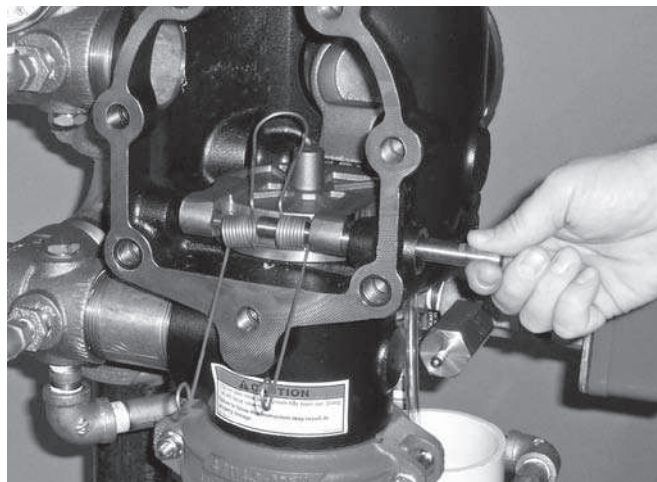
12. Replace the cover plate by following the “Installing the Cover Plate Gasket and Cover Plate” section.
13. Place the system back in service by following the “Placing the System in Service” section.

### REMOVING AND REPLACING THE CLAPPER ASSEMBLY

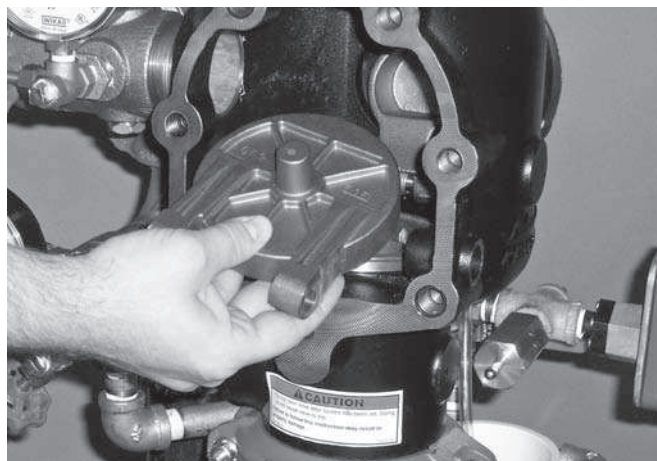
1. Perform steps 1 – 12 of the “Required Internal Inspection” section.



2. Remove the clapper shaft bushings from the valve body.



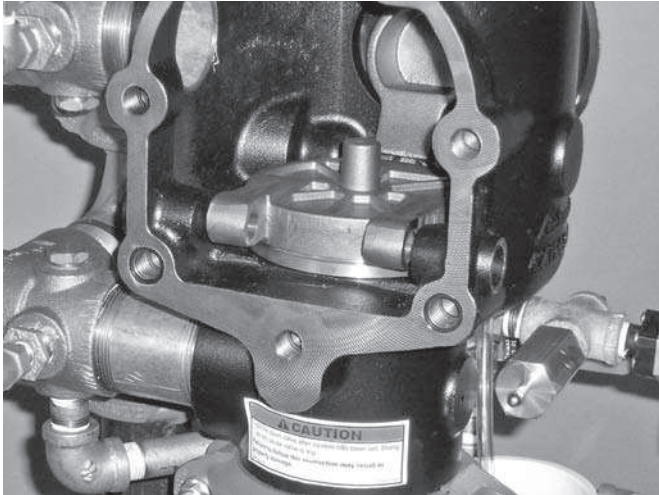
3. Remove the clapper shaft. **NOTE:** As the shaft is being removed, the clapper spring will drop out of position. Keep the clapper spring for re-installation.



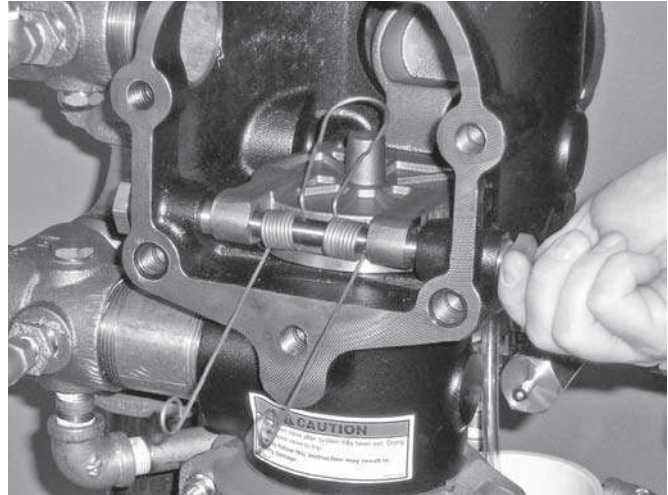
4. Remove the clapper from the valve body.

## FireLock NXT™ Preaction Valve

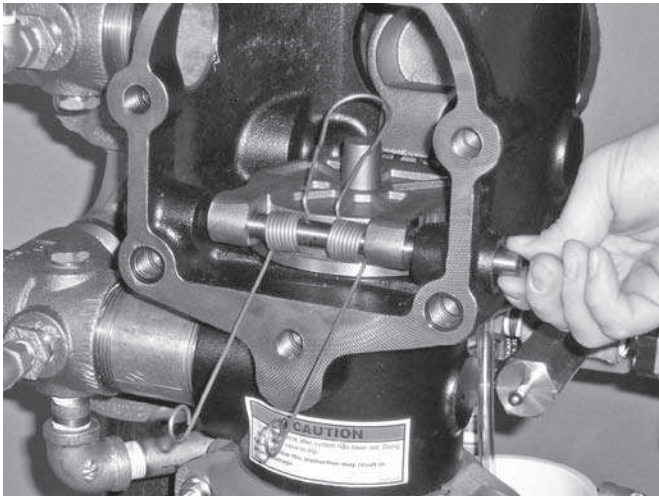
SERIES 769



5. Place the new clapper assembly onto the valve-body seat ring. Make sure the holes in the clapper arms align with the holes in the valve body.



9. Apply thread sealant to the clapper shaft bushings. Install the clapper shaft bushings into the valve body until hand-tight.
10. Tighten the clapper shaft bushings until metal-to-metal contact occurs with the valve body.



6. Insert the clapper shaft halfway into the valve body.
7. Install the clapper spring onto the clapper shaft. Make sure the loop of the clapper spring is facing toward the clapper, as shown above.
8. Finish inserting the clapper shaft through the clapper arm and valve body.



11. Check the clapper for freedom of movement.
12. Replace the cover plate by following the "Installing the Cover Plate Gasket and Cover Plate" section.
13. Place the system back in service by following the "Placing the System in Service" section.



# FireLock NXT™ Preaction Valve

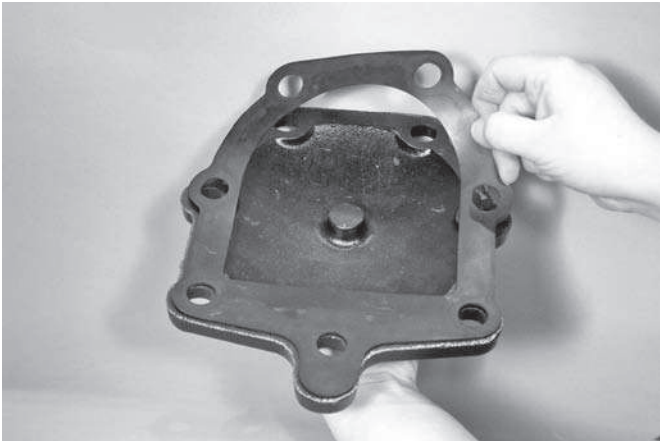
SERIES 769

## INSTALLING THE COVER PLATE GASKET AND COVER PLATE

**CAUTION**

- Use only Victaulic-supplied replacement parts. Failure to follow this instruction could cause improper valve operation, resulting in property damage.

1. Verify that the cover plate gasket is in good condition. If the gasket is torn or worn, replace it with a new, Victaulic-supplied gasket.



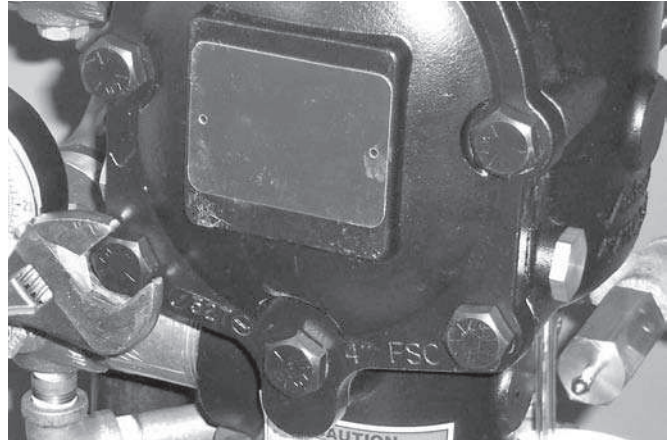
2. Align the holes of the cover plate gasket with the holes in the cover plate.



3. Insert one cover plate bolt through the cover plate and cover plate gasket to ease alignment. **NOTE:** For 1 1/2-inch/48.3-mm and 2-inch/60.3-mm valve sizes, a washer must be re-installed under the head of each cover plate bolt.

**CAUTION**

- DO NOT over-tighten the cover plate bolts. Failure to follow this instruction could cause damage to the cover plate gasket, resulting in valve leakage.



4. Align the cover plate/cover plate gasket to the valve. Make sure the clapper spring's arms are rotated to their installed position. Tighten all cover plate bolts into the cover plate/valve body.
5. Torque all cover plate bolts in an even, crossing pattern. Refer to the "Required Cover Plate Bolt Torques" table below for the required torque values. DO NOT over-tighten the cover plate bolts.

### REQUIRED COVER PLATE BOLT TORQUES

Size		Torque
Nominal Size inches	Actual Outside Diameter inches mm	ft-lbs N•m
1 1/2	1.900	30
	48.3	41
2	2.375	30
	60.3	41
2 1/2	2.875	60
	73.0	81
76.1 mm	3.000	60
	76.1	81
3	3.500	60
	88.9	81
4	4.500	100
	114.3	136
165.1 mm	6.500	115
	165.1	156
6	6.625	115
	168.3	156
8	8.625	100
	219.1	136

6. Place the system back in service by following the "Placing the System in Service" section.

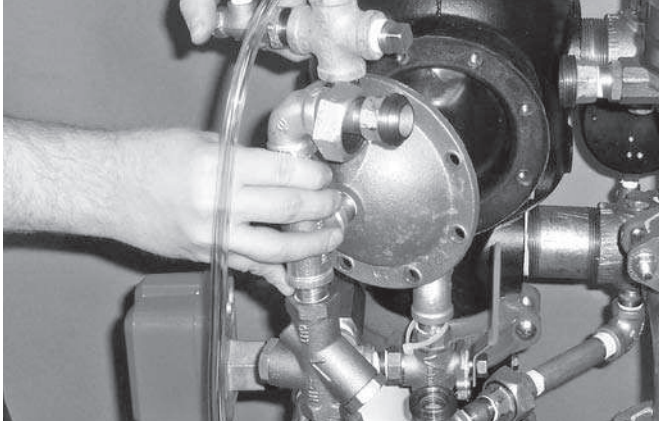


# FireLock NXT™ Preaction Valve

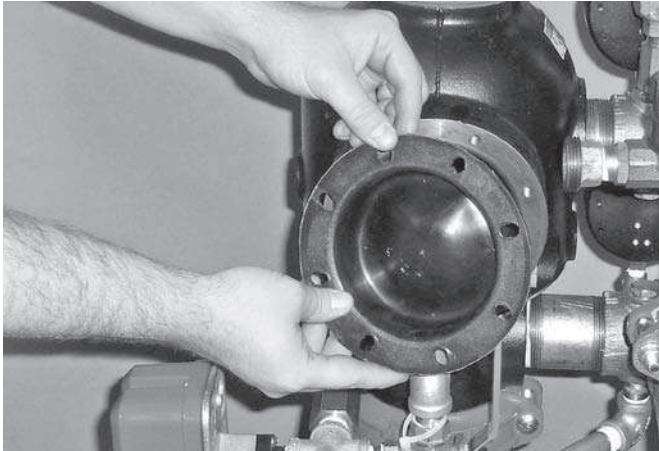
SERIES 769

## REMOVING AND REPLACING THE DIAPHRAGM ASSEMBLY

1. Remove the system from service by following steps 1 – 11 of the “Required Internal Inspection” section.
2. Break the unions that connect the trim to the diaphragm cover. Refer to the applicable trim drawing for details.



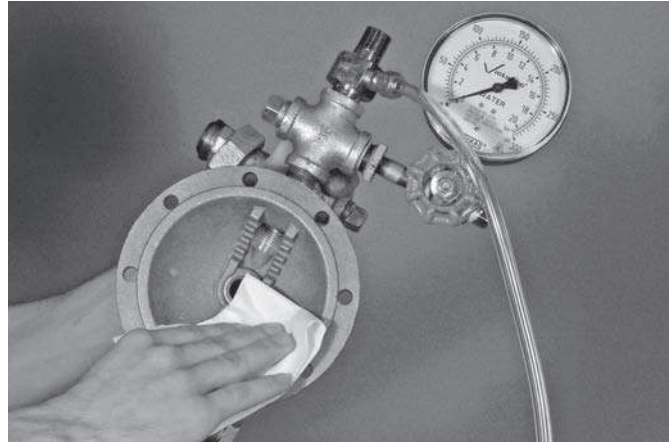
3. Remove the cap screws from the diaphragm cover, and pull the diaphragm cover/trim off the valve.



4. Remove the diaphragm from the valve body.



5. Clean the back of the valve body to remove any debris that may interfere with proper diaphragm seating.



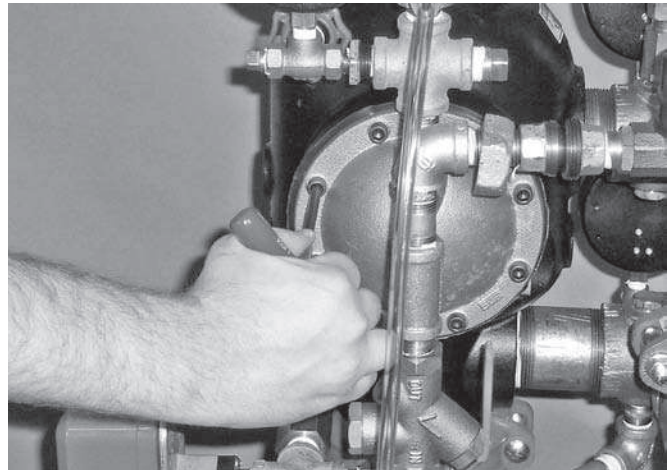
- 5a. Clean the inside of the diaphragm cover to remove any foreign material.

### CAUTION

- Use caution when installing a new diaphragm into the valve body.

Failure to follow this instruction could cause damage to the diaphragm, resulting in improper valve operation and valve leakage.

6. Replace the diaphragm with a new, Victaulic-supplied diaphragm. Align the holes in the diaphragm with the holes in the valve body. Be careful not to damage the diaphragm during installation.



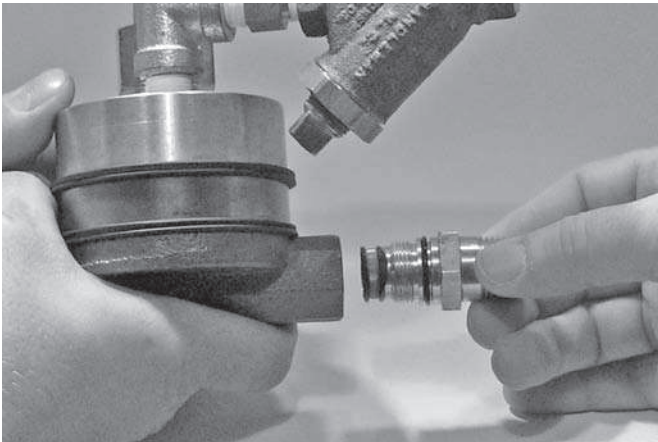
7. Align the holes of the diaphragm cover with the holes in the diaphragm/valve body. Tighten all cap screws into the diaphragm cover/valve body.
8. Re-attach the trim at the unions that were loosened in step 2. Refer to the applicable trim drawing for details. **MAKE SURE ALL UNIONS THAT WERE LOOSENED TO PERMIT ACCESS TO THE DIAPHRAGM COVER ARE RE-TIGHTENED BEFORE ATTEMPTING TO PLACE THE SYSTEM BACK IN SERVICE.**
9. Place the system back in service by following the “Placing the System in Service” section.

## FireLock NXT™ Preaction Valve

### SERIES 769

#### REPLACING THE STRAINER SCREEN FOR SERIES 776 LOW-PRESSURE ACTUATORS

1. Remove the system from service by following steps 1 – 11 of the “Required Internal Inspection” section.
2. Remove the Series 776 Low-Pressure Actuator from the trim. Refer to the applicable trim drawing for details.



3. Remove the strainer assembly from the Series 776 Low-Pressure Actuator, as shown above. Discard the strainer screen only.

#### CAUTION

- **DO NOT re-use strainer screens. After removal, the old strainer screen must be replaced with a new, Victaulic-supplied screen.**

**Failure to follow this instruction could cause improper valve operation, resulting in property damage.**

4. Use only a new, Victaulic-supplied strainer screen. Insert the strainer screen into the strainer assembly.
5. Install the strainer assembly into the Series 776 Low-Pressure Actuator carefully. Avoid damage to the o-ring seals.
6. Re-install the Series 776 Low-Pressure Actuator into the trim. Refer to the applicable trim drawing for details.
7. Place the system back in service by following the “Placing the System in Service” section.

# FireLock NXT™ Preaction Valve

SERIES 769

## TROUBLESHOOTING – SERIES 776 LOW-PRESSURE ACTUATOR

Problem	Possible Cause	Solution
When the Auto Vent Sleeve of the Series 776 Low-Pressure Actuator is pulled up, the screw does not stay set in the “UP” position.	The Series 776 Low-Pressure Actuator is not receiving enough air.	Increase the air pressure going into the Series 776 Low-Pressure Actuator.
	The Series 776 Low-Pressure Actuator has a broken seal.	If the above procedure does not work, contact Victaulic.
Water is leaking through the Series 776 Low-Pressure Actuator.	The air chamber of the Series 776 Low-Pressure Actuator is not set.	Make sure the vent seal of the Series 776 Low-Pressure Actuator is in the set position and the air chamber is pressurized.
	The strainer on the Series 776 Low-Pressure Actuator is clogged.	Replace the strainer screen of the Series 776 Low-Pressure Actuator. Refer to the “Replacing the Strainer Screen for Series 776 Low-Pressure Actuators” section.
	The Series 776 Low-Pressure Actuator has a ripped diaphragm.	If water still leaks through the Series 776 after performing the above procedures, contact Victaulic.
No water is passing through the Series 776 Low-Pressure Actuator.	The strainer on the diaphragm charge line is clogged.	Disassemble and clean the diaphragm charge line strainer. Refer to the applicable trim drawing for details.

## TROUBLESHOOTING – SERIES 753-E SOLENOID VALVE

Problem	Possible Cause	Solution
No water is passing through the Series 753-E Solenoid Valve.	The strainer on the diaphragm charge line is clogged.	Disassemble and clean the diaphragm charge line strainer. Refer to the applicable trim drawing for details.
The Series 776 Low Pressure Actuator does not open.	No power is going to the solenoid.	Check all electrical connections to make sure power is being supplied to the solenoid.

## TROUBLESHOOTING – SERIES 746-LPA DRY ACCELERATOR

Problem	Possible Cause	Solution
The valve operates without sprinkler activation.	There is a loss of air pressure in the lower inlet chamber of the Series 746-LPA Dry Accelerator.	Check for air loss at the lower chamber seal. If a leak is present, turn the adjustment nut counterclockwise to seal.
		Check for any leaks in the system and trim. Confirm that the AMTA is operating properly.
The Series 746-LPA Dry Accelerator does not operate within a 5-psi/34-kPa/0.3-Bar pressure drop in system air pressure.	There is a loss of air pressure in the upper air chamber of the Series 746-LPA Dry Accelerator.	Apply soapy water to all joints around the Series 746-LPA Dry Accelerator to check for leaks. Repair any leaks and re-test.
	The air decay rate of the system is too slow.	Make sure there are no restrictions in the remote system test valve (inspector’s test connection). If the above procedures do not work, contact Victaulic.
The Series 746-LPA Dry Accelerator does not set up properly (cannot get pressure on the upper gauge, and the button pops up immediately when pressure is introduced).	The Series 746-LPA Dry Accelerator is installed upside-down.	Remove the Series 746-LPA Dry Accelerator from the trim, and turn the unit around so that the vent seal “button” is facing down (toward the Series 776 Low-Pressure Actuator).

# FireLock NXT™ Preaction Valve

SERIES 769

## TROUBLESHOOTING – SYSTEM

Problem	Possible Cause	Solution
The valve operates without sprinkler activation.	There is a loss of air pressure in the system or trim.	Check for any leaks in the system and trim. Confirm that the AMTA is operating properly. Consider installing a low-air supervisory switch.
	The pressure switch on the air compressor is set too low, or the compressor is not operating properly.	Increase the "ON" setting of the air compressor's pressure switch, and check the air compressor for proper operation.
Water is leaking from the drip check located in the alarm line.	Water is getting past the clapper seal and into the intermediate chamber of the valve.	Check the clapper seal and valve body seat ring for physical damage and foreign material.
	Water is under the clapper seal.	Inspect the clapper seal to make sure no water is under the seal. If water is present, remove and replace the seal. Refer to the "Removing and Replacing the Clapper Seal" section.
Air is leaking from the drip check located in the alarm line.	Air is getting past the clapper seal and into the intermediate chamber of the valve.	Check the clapper seal and valve body seat ring for physical damage and foreign material.
	Water is under the clapper seal.	Inspect the clapper seal to make sure no water is under the seal. If water is present, remove and replace the seal. Refer to the "Removing and Replacing the Clapper Seal" section.
The clapper will not latch closed.	There is no water pressure on the diaphragm.	Check the water pressure in the diaphragm charge line. Make sure the restrictor in the diaphragm charge line is clean.
	The Auto Drain is not set.	Set the Auto Drain by pulling up on the Auto Drain Sleeve.
Water is leaking from the diaphragm assembly.	The diaphragm is damaged.	Contact Victaulic.
Air is leaking from the diaphragm assembly.	The diaphragm is damaged.	Contact Victaulic.





## FireLock NXT™ Preaction Valve

### SERIES 769

NON-INTERLOCKED, PNEUMATIC RELEASE WITH SERIES 776 LOW-PRESSURE ACTUATOR

NON-INTERLOCKED, PNEUMATIC/ELECTRIC RELEASE WITH SERIES 776 LOW-PRESSURE ACTUATOR AND SERIES 753-E SOLENOID VALVE

SINGLE-INTERLOCKED, PNEUMATIC RELEASE WITH SERIES 776 LOW-PRESSURE ACTUATOR

SINGLE-INTERLOCKED, ELECTRIC RELEASE WITH SERIES 753-E SOLENOID VALVE

DOUBLE-INTERLOCKED, ELECTRIC (ELECTRIC-PNEUMATIC/ELECTRIC) RELEASE WITH SERIES 753-E SOLENOID VALVE

---



WCAS-7EFFBU

For complete contact information, visit [www.victaulic.com](http://www.victaulic.com)

I-769P 4259 REV D UPDATED 05/2008 Z000769P00

VICTAULIC IS A REGISTERED TRADEMARK OF VICTAULIC COMPANY. © 2007 VICTAULIC COMPANY. ALL RIGHTS RESERVED. PRINTED IN THE USA.

I-769P



PREACTION-PAC  
with NOTIFIER NFS2-640 RELEASING CONTROL PANEL  
INSTALLATION, OPERATION, AND MAINTENANCE MANUAL  
P/N 10-500001-00B  
VERSION 1.1 – JULY 2011

# SECTION

# 3

General Air Products  
Manual OILLESSINST

Compressor

## OIL-LESS COMPRESSOR INSTRUCTION SHEETS

### NOTE

This compressor is intended for installation indoors for use on dry sprinkler systems in accordance with the Standard for Installation of Sprinkler Systems, NFPA 13 and the National Electrical Code, NFPA 70. The compressor should be sized to restore and maintain the air pressure in the sprinkler system in accordance with the requirements in NFPA 13.

### DANGER

This compressor is not equipped and should NOT be used "as is" to supply breathing quality air.

### WARNING

Motors, electrical equipment and controls can cause electrical arcs that will ignite a flammable gas or vapor. Never operate or repair in or near a flammable gas or vapor. Never store flammable liquids or gases near the compressor.

### WARNING

These compressors are suitable for pumping only atmospheric air. As defined in Compressed Gas Association Pamphlet G-7, page 3, atmospheric air is a mixture of elements and compounds where nitrogen and oxygen comprise more than 99% with all other trace gases comprising less than 1%. **DO NOT USE THIS COMPRESSOR IN CONTAMINATED ENVIRONMENTS OR FOR PUMPING MIXTURES OTHER THAN ATMOSPHERIC AIR**

### WARNING

Compressed air contains liquid water and is saturated with water vapor, which can freeze. Do not connect compressor outlet to freezer rooms or systems exposed to temperatures below freezing. If system connects to a freezer room or area exposed to freezing temperatures, a Dry Air Pac™ should be used.

### Receiving

Your compressor is inspected at the factory and packaged to protect against shipping damage. When the compressor is unpacked, inspect for damage or missing parts. All claims should be settled directly with the freight company.

**WARNING: Do not operate this compressor if damaged during shipment, handling, or use. Damage may result in bursting and cause injury or property damage.**

### Location

**NOTE: Do not connect compressor intake to freezer room. – CALL 1-800-345-8207.**

Locate the compressor in a clean, well-ventilated area where the air is relatively cool, clean, and dry. A 110°F (35 C) maximum and 40°F (4.5 C) minimum temperature for surrounding and inlet air are recommended. Provide at least 12 to 18 inches from any wall or other obstruction that will interfere with airflow through the motor's fan built into the motor. Blocking airflow through the fan may cause the compressor to over heat. Do not place the compressor in an area of excessive heat, such as near a boiler.

### Mounting

Riser mounted compressors may be mounted to a firm level floor, wall or system riser. A mounting bracket

and straps are provided. Tank mounted compressors should be bolted to the floor using the bolt holes provided in the tank legs. Always shim the unit level before bolting it to the floor. Vibration isolators (P/N KVP4X4) are recommended. When using isolator pads, do not draw bolts tight. Allow the pad to absorb vibrations. When isolators are used, a flexible hose (P/N P1202MP) should be installed between the compressor and service piping.

### Lubrication

**NOTE:** This compressor is designed for non-lubricated service. Bearings are permanently lubricated. Do not lubricate any part of the compressor or motor.

### Piping (reference "Installation Instructions" drawings)

### WARNING

Compressed air contains liquid water and is saturated with water vapor, which can freeze. Do not connect compressor outlet to freezer rooms or systems exposed to temperatures below freezing. If system connects to a freezer room or area exposed to freezing temperatures, a Dry Air Pac™ should be used.

Piping between the compressor, accessory items and the sprinkler system should be at least ½" internal

For Assistance Please Call 1-800 345-8207

Please keep these instructions for future reference.

# ✿GENERAL AIR PRODUCTS, INC.

diameter to minimize pressure drop from the compressor to system. Larger pipe size may be required by code and may be substituted with no adverse effects. Smaller line size must not be used and will restrict the compressor flow, lowering capacity and causing the compressor/motor to work harder, which shortens compressor/motor life. All piping connected to the compressor must be fully supported and not transfer any loads to the compressor.

If an AMD-1 is used, allow sufficient distance between the compressor and AMD-1 to ensure that the maximum temperature at the AMD-1 is 200°F or less.

**When an AMD is used with riser mounted units, a riser mounted tank kit (p/n OLR-TK) should be installed to prevent short cycling the compressor.**

All oil-less compressors include a relief valve. For riser mounted models, the relief valve is installed on the compressor outlet. For tank mounted models, an ASME Code relief valve is mounted on the compressor's tank. This valve will open at a preset value above the pressure switch setting to prevent excess tank pressure in the event of switch failure.

**WARNING:** Do not attempt to change the safety relief valve setting.

A manual drain is provided on the bottom of each tank mounted compressor. Moisture accumulated in the tank, must be drained weekly. An automatic drain , P/N DVA-2T, is recommended in areas of high humidity.

The compressor outlet piping should contain an accessible drain. As a minimum a manual drain may be used, but an automatic drain is recommended to remove excess water.

**NOTE:** Accumulation of condensed water in a system causes corrosion of components and reduces system capacity.

**NOTICE:** Warranty is void if a separate check valve is not installed to prevent water back flow.

Wiring (reference "Wiring Instructions" drawings)

**WARNING**

Have a qualified electrician wire the compressor to ensure that the supply line has the same characteristics (voltage, frequency and phasing) as the motor. Wiring must comply with all local and national codes.

## CAUTION

Inadequate wiring size can cause insufficient voltage at the compressor during start-up. Overheating and damage to the motor and controls may result

The supply wire must be of adequate size and no other equipment should be connected to the same line. The table below lists the recommended wire size for each model, based on a 100' run. Consult factory for longer runs.

MINIMUM RECOMMENDED WIRE SIZE		
MODEL	1 PHASE	3 PHASE
OL11016**	12	N/A
OL21533**	10	N/A
OL33550**	8	12
OL42575**	8	12
OL435V75**	8	12
OL525100**	8	12
OL610V100**	8	12
OL675150**	6	12
OL900V100**	8	12
OL900V150**	8	12
OL1200V200**	10	10

The motors supplied are multiple voltage motors. A label on the pressure switch cover indicates the voltage the motor is pre-wired for. If the supply voltage, on site, is different from the voltage indicated on this label, change the internal motor voltage connections to match the supply voltage. To change internal voltage connections, remove the cover plate located on the rear or side of the motor and reconnect the wire leads as shown on the motor's wiring diagram.

On all three phase and ½ Hp and ¾ Hp single phase models, an arrow on the motor indicates the direction of rotation of the compressor. If the compressor rotates in the opposite direction, reverse the rotation of the motor. On single phase units, reverse motor rotation by interchanging the red and black motor leads. Interchanging any two incoming supply wires reverses rotation of three phase motors.

**NOTICE:** **Single-phase oil-less compressors can not be operated at 208V. Operating the compressor at 208V voids the warranty.**

**NOTICE:** Single-phase motors include internal thermal overload protection, which has an automatic reset device.

**WARNING:** Disconnect electrical power before servicing to disable reset devices. Thermal protection can automatically start the motor when the protector resets.

On single phase models, the motor is pre-wired to the pressure switch provided, which controls starting (cut

## **GENERAL AIR PRODUCTS, INC.**

in pressure) and stopping (cut out pressure) of the motor. The pressure switch is factory set. Standard models switch is set at 27 psig cut in and 40 psig cut out. Low pressure models (“-LP”) switch is set at 13 psig cut in and 18 psig cut out. Consult General Air Products before adjusting the pressure switch.

On three-phase compressors, the motor is not pre-wired to the pressure switch. Refer to the three phase wiring instruction drawing for recommended wiring.

A magnetic starter is required, for all three phase models, to protect the motor from overload conditions. A magnetic starter is recommended, for all single phase models. Consult the National Electric Code and local codes for motor starter requirements. Refer to

the proper wiring instruction drawing for recommended wiring to a starter.

**NOTE:** Do not run two phases of a three phase supply through the pressure switch. Serious damage can result.

**NOTE:** Failure to use the pressure switch may result in overpressure of the compressor or other components in the system. Overpressure of the compressor may result in blown head gaskets or other damage.

### Maintenance Instructions

**WARNING**  
DISCONNECT, TAG AND LOCK OUT POWER SOURCE THEN RELEASE ALL PRESSURE FROM THE SYSTEM BEFORE ATTEMPTING TO INSTALL, SERVICE, RELOCATE OR PERFORM ANY SERVICE.

The following instructions are based on NORMAL operation. If the compressor is in an excessively dusty area, increase frequency of maintenance checks.

#### WEEKLY

- Drain condensate from receiver and traps.
- Check for unusual noise or vibration.
- Clean air filters. – **NOTE: Do not clean filters with petroleum based products.**
- Clean all external parts of the compressor and motor.

#### MONTHLY

- Manually test safety relief valve.
- Inspect air system for leaks and tighten nuts and cap screws as required.

#### QUARTERLY

- Change filters.

### Limited Warranty

General Air Products, Inc. warrants its products to be free of defects in material and workmanship under normal use and service for 12 months from date of purchase. Our warranty applies only when such defective parts are returned to us, or our Authorized Service Depot, transportation prepaid, and subject to our inspection and approval. Liability is limited to repair or replacement of material found defective, free of charge, FOB our plant. Unauthorized repairs or replacements will not be subject to factory warranty. This warranty is in lieu of all other warranties, expressed or implied.

### General Notes

- 1) Warranty can be voided if modifications or adjustments are made without consultation and approval; from factory personnel.
- 2) If there are any questions regarding installation or operation of this compressor, please call the 800 number listed below.

 **GENERAL AIR PRODUCTS, INC.**

For Assistance Please Call 1-800 345-8207  
Please keep these instructions for future reference.

OILLESSINST  
REV 080906



** GENERAL AIR PRODUCTS, INC.**

**Trouble Shooting Guide**

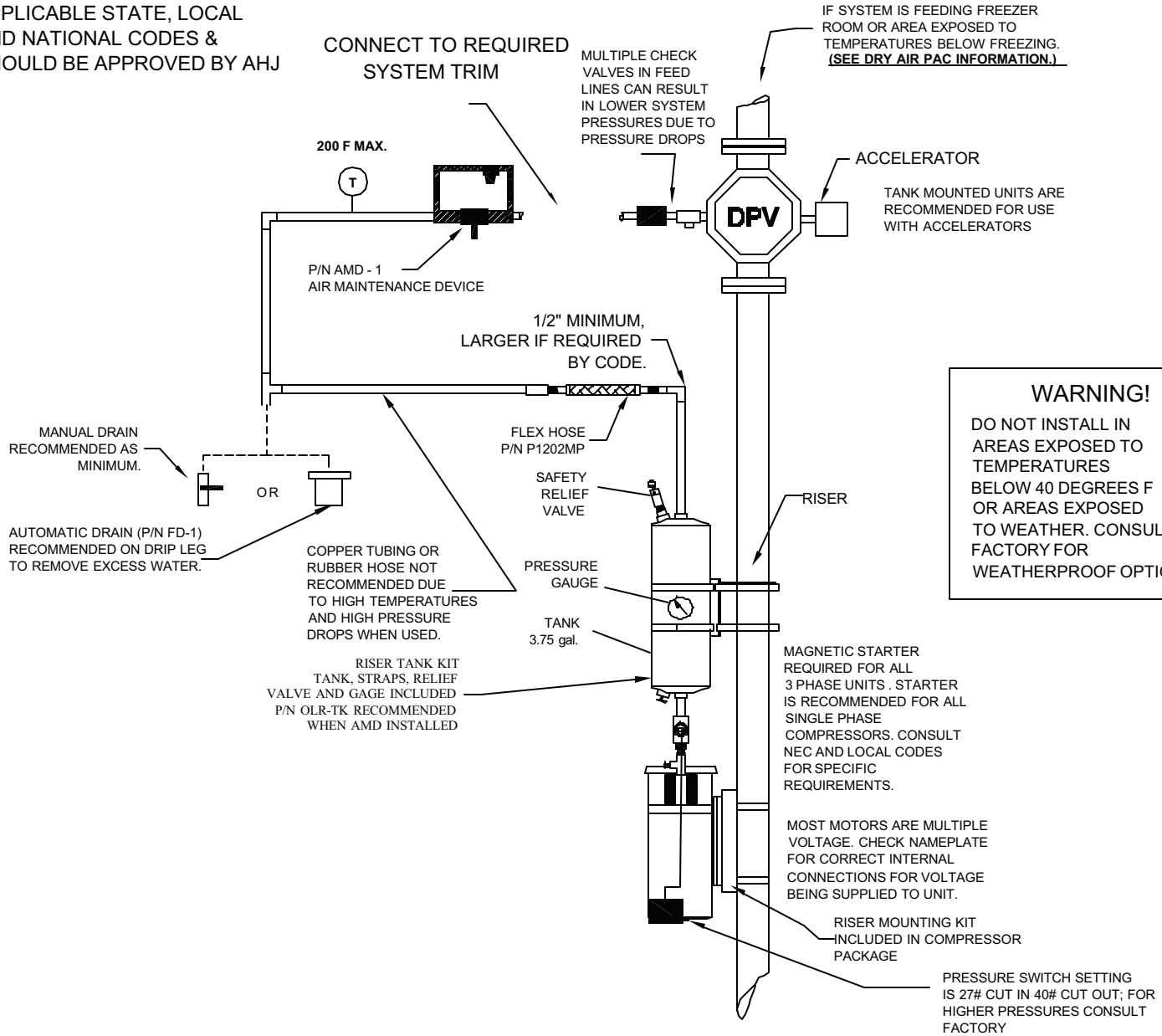
Symptom	Possible Cause(s)	Corrective Action
Motor hums and runs slowly or not at all	<ol style="list-style-type: none"> <li>1. Low voltage or no voltage</li> <li>2. Shorted or open motor winding</li> <li>3. Defective check valve</li> <li>4. Defective pressure switch – contacts will not close</li> </ol>	<ol style="list-style-type: none"> <li>1. Check voltage during attempt to start. Voltage must be within +/-10% of nominal voltage to start motor. Increase wire size if necessary to lower voltage drop.</li> <li>2. Replace motor</li> <li>3. Replace check valve</li> <li>4. Repair or replace pressure switch</li> </ol>
Reset mechanism cuts out repeatedly or fuses blow repeatedly	<ol style="list-style-type: none"> <li>1. Insufficient voltage to motor</li> <li>2. Pressure switch set too high</li> <li>3. Wrong fuse size</li> <li>4. Piping too restrictive</li> <li>5. Defective motor</li> </ol>	<ol style="list-style-type: none"> <li>1. Check voltage during attempt to start. Voltage must be within +/-10% of nominal voltage to start motor. Increase wire size if necessary to lower voltage drop.</li> <li>2. Consult factory, adjust or replace</li> <li>3. Be sure fuses and heaters are rated properly</li> <li>4. Add receiver vessel or increase pipe volume after compressor.</li> <li>5. Replace motor</li> </ol>
Unit short cycles repeatedly	<ol style="list-style-type: none"> <li>1. Piping too restrictive</li> <li>2. Leak in line before system check valve</li> </ol>	<ol style="list-style-type: none"> <li>1. Add receiver vessel or increase pipe volume after compressor.</li> <li>2. Repair leaks(s)</li> </ol>
Compressor Overheating	<ol style="list-style-type: none"> <li>1. Dirty intake filter</li> <li>2. Wrong motor rotation</li> <li>3. Air flow to fan on flywheel blocked</li> </ol>	<ol style="list-style-type: none"> <li>1. Clean intake filter</li> <li>2. Correct rotation</li> <li>3. Clear air flow to fan or relocate unit</li> </ol>
Excessive noise in operation	<ol style="list-style-type: none"> <li>1. Damaged bearings</li> <li>2. Worn piston rings or skirts</li> <li>3. Broken valves</li> <li>4. Loose blower wheel</li> <li>5. Damaged Blower baffle</li> </ol>	<ol style="list-style-type: none"> <li>1. Contact General Air Products, Inc. Service Department. 1-(800)345-8207</li> </ol>
System pressure builds slowly	<ol style="list-style-type: none"> <li>1. Compressor sized incorrectly</li> <li>2. Leaks or restrictions in piping</li> <li>3. Dirty intake filter</li> <li>4. Blown head gasket</li> </ol>	<ol style="list-style-type: none"> <li>1. Check system size and compressor sizing</li> <li>2. Correct leaks and remove restrictions</li> <li>3. Clean intake filter</li> <li>4. Replace head gasket</li> </ol>

For Assistance Please Call 1-800 345-8207  
Please keep these instructions for future reference.

# RISER MOUNT OIL-LESS COMPRESSORS WITH RISER TANK KIT INSTALLATION INSTRUCTIONS



ALL PIPING AND WIRING TO BE IN ACCORDANCE WITH APPLICABLE STATE, LOCAL AND NATIONAL CODES & SHOULD BE APPROVED BY AHJ

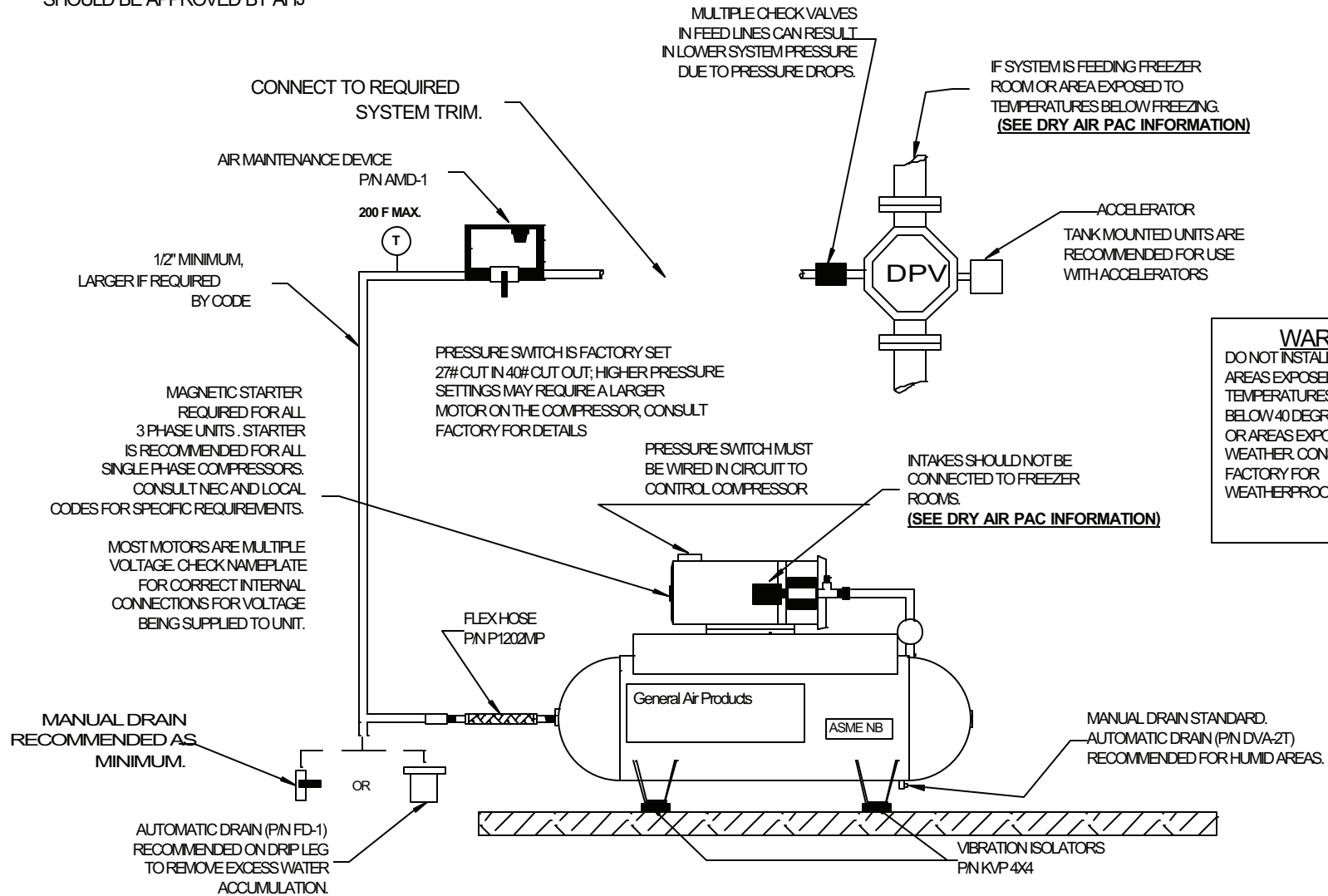


PART NUMBERS LISTED ARE FOR ACCESSORY ITEMS RECOMMENDED FOR COMPLETE INSTALLATION - CONSULT YOUR LOCAL DISTRIBUTOR FOR AVAILABILITY

# TANK MOUNTED OIL-LESS COMPRESSORS INSTALLATION INSTRUCTIONS



ALL PIPING AND WIRING TO BE IN ACCORDANCE WITH APPLICABLE STATE, LOCAL AND NATIONAL CODES & SHOULD BE APPROVED BY AHJ



PART NUMBERS LISTED ARE FOR ACCESSORY ITEMS RECOMMENDED FOR COMPLETE INSTALLATION - CONSULT YOUR LOCAL DISTRIBUTOR FOR AVAILABILITY

# OIL-LESS COMPRESSOR SINGLE PHASE WIRING INSTRUCTIONS

NOTE: MOST MOTORS ARE MULTIPLE VOLTAGE. CHECK NAMEPLATE AND VERIFY CORRECT INTERNAL CONNECTIONS FOR VOLTAGE BEING SUPPLIED TO UNIT.

FEEDER WIRE SIZE MUST BE CAPABLE OF CARRYING CURRENT LOAD OF COMPRESSOR AT MAXIMUM PRESSURE.

**FIG 1**

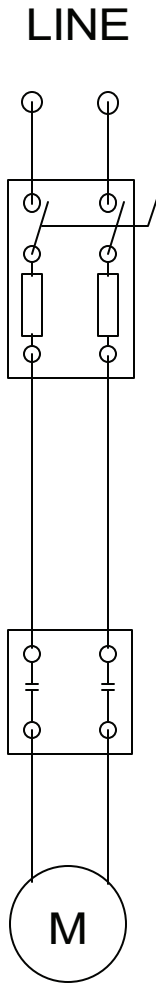
SINGLE PHASE BUILT IN OVERLOAD PROTECTION. (NOT TO EXCEED 3/4 HP).

FOR 115V ELIMINATE FUSE IN GROUND LEG.

PRESSURE SWITCH HP RATING MUST NOT BE EXCEEDED.

OTHER WIRING VARIATIONS POSSIBLE DEPENDING ON LOCAL CODES.

PRESSURE SWITCH



**FIG 1**

**FIG 2**

SINGLE PHASE WITH OR WITHOUT OVERLOAD PROTECTION.

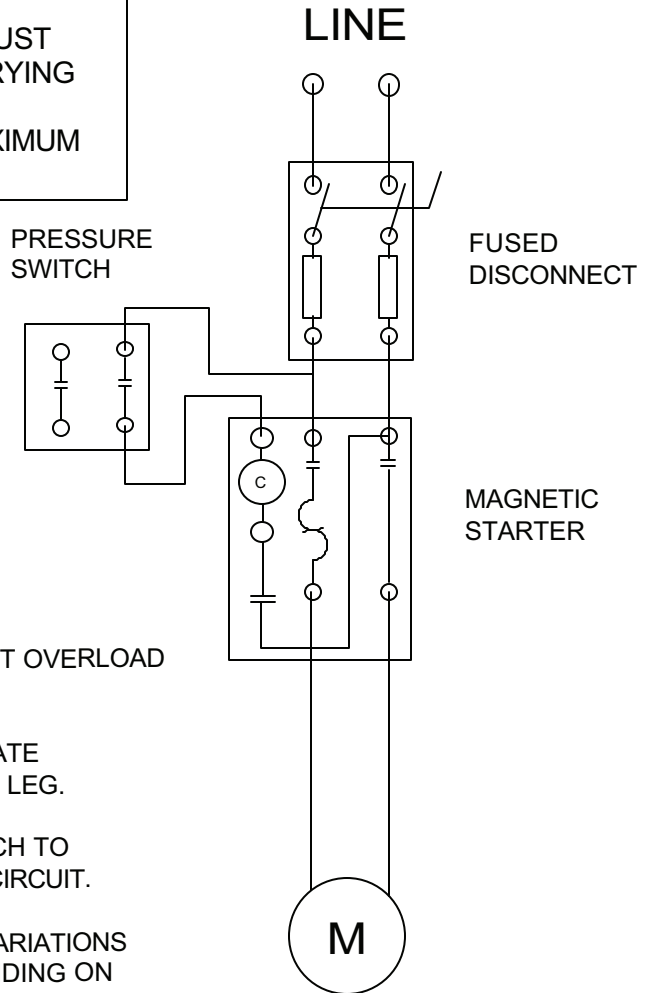
FOR 115V ELIMINATE FUSE IN GROUND LEG.

PRESSURE SWITCH TO CONTROL PILOT CIRCUIT.

OTHER WIRING VARIATIONS POSSIBLE DEPENDING ON LOCAL CODES.

CONSULT MANUFACTURER'S INSTRUCTIONS ON STARTER FOR VARIATIONS ON DIAGRAM SHOWN.

PRESSURE SWITCH



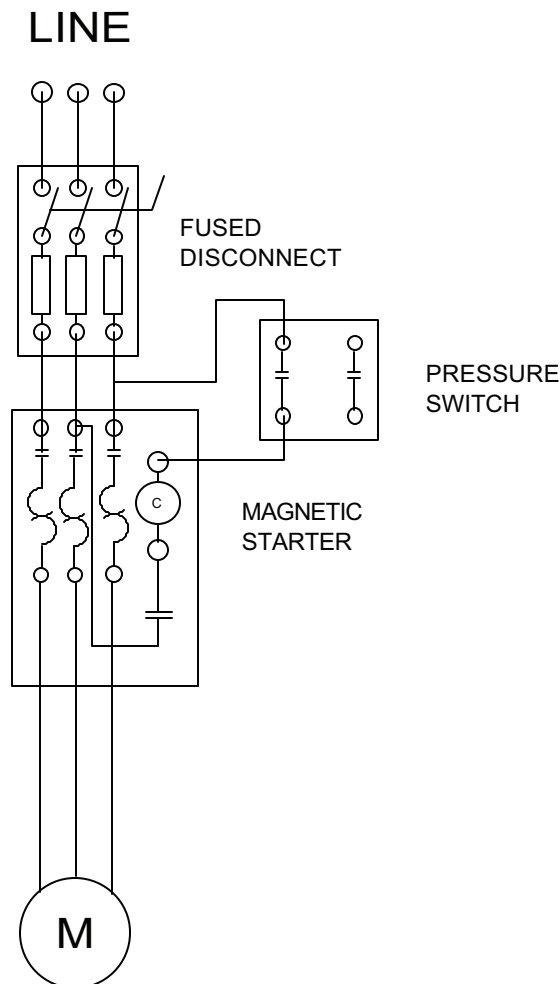
**FIG 2**

# OIL-LESS COMPRESSOR THREE PHASE WIRING INSTRUCTIONS



NOTE: MOST MOTORS ARE MULTIPLE VOLTAGE. CHECK NAMEPLATE AND VERIFY CORRECT INTERNAL CONNECTIONS FOR VOLTAGE BEING SUPPLIED TO UNIT.

FEEDER WIRE SIZE MUST BE CAPABLE OF CARRYING CURRENT LOAD OF COMPRESSOR AT MAXIMUM PRESSURE.



THREE PHASE

OTHER WIRING VARIATIONS POSSIBLE DEPENDING ON LOCAL CODES

PRESSURE SWITCH TO CONTROL PILOT CIRCUIT

CONSULT MANUFACTURERS INSTRUCTIONS ON STARTER FOR VARIATIONS ON DIAGRAM SHOWN

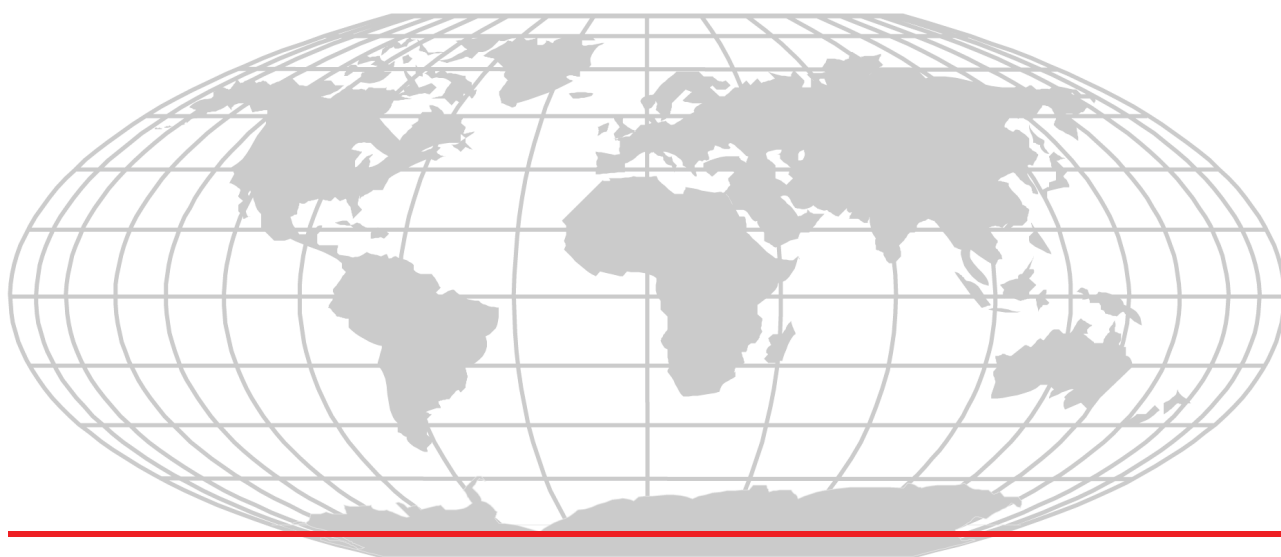


# SECTION

# 4.1

Notifier Manual 52741

NFS2-640 Control Panel  
Installation



---

**Fire Alarm Control Panel**  
**NFS2-640/E**  
**Installation Manual**

# Fire Alarm System Limitations

*While a fire alarm system may lower insurance rates, it is not a substitute for fire insurance!*

**An automatic fire alarm system**—typically made up of smoke detectors, heat detectors, manual pull stations, audible warning devices, and a fire alarm control panel with remote notification capability—can provide early warning of a developing fire. Such a system, however, does not assure protection against property damage or loss of life resulting from a fire.

The Manufacturer recommends that smoke and/or heat detectors be located throughout a protected premise following the recommendations of the current edition of the National Fire Protection Association Standard 72 (NFPA 72), manufacturer's recommendations, State and local codes, and the recommendations contained in the Guides for Proper Use of System Smoke Detectors, which are made available at no charge to all installing dealers. These documents can be found at <http://www.systemsensor.com/html/applicat.html>. A study by the Federal Emergency Management Agency (an agency of the United States government) indicated that smoke detectors may not go off in as many as 35% of all fires. While fire alarm systems are designed to provide early warning against fire, they do not guarantee warning or protection against fire. A fire alarm system may not provide timely or adequate warning, or simply may not function, for a variety of reasons:

**Smoke detectors** may not sense fire where smoke cannot reach the detectors such as in chimneys, in or behind walls, on roofs, or on the other side of closed doors. Smoke detectors also may not sense a fire on another level or floor of a building. A second-floor detector, for example, may not sense a first-floor or basement fire.

**Particles of combustion or "smoke"** from a developing fire may not reach the sensing chambers of smoke detectors because:

- Barriers such as closed or partially closed doors, walls, or chimneys may inhibit particle or smoke flow.
- Smoke particles may become "cold," stratify, and not reach the ceiling or upper walls where detectors are located.
- Smoke particles may be blown away from detectors by air outlets.
- Smoke particles may be drawn into air returns before reaching the detector.

The amount of "smoke" present may be insufficient to alarm smoke detectors. Smoke detectors are designed to alarm at various levels of smoke density. If such density levels are not created by a developing fire at the location of detectors, the detectors will not go into alarm.

Smoke detectors, even when working properly, have sensing limitations. Detectors that have photoelectronic sensing chambers tend to detect smoldering fires better than flaming fires, which have little visible smoke. Detectors that have ionizing-type sensing chambers tend to detect fast-flaming fires better than smoldering fires. Because fires develop in different ways and are often unpredictable in their growth, neither type of detector is necessarily best and a given type of detector may not provide adequate warning of a fire.

Smoke detectors cannot be expected to provide adequate warning of fires caused by arson, children playing with matches (especially in bedrooms), smoking in bed, and violent explosions (caused by escaping gas, improper storage of flammable materials, etc.).

**Heat detectors** do not sense particles of combustion and alarm only when heat on their sensors increases at a predetermined rate or reaches a predetermined level. Rate-of-rise heat detectors may be subject to reduced sensitivity over time. For this reason, the rate-of-rise feature of each detector should be tested at least once per year by a qualified fire protection specialist. Heat detectors are designed to protect property, not life.

**IMPORTANT! Smoke detectors** must be installed in the same room as the control panel and in rooms used by the system for the connection of alarm transmission wiring, communications, signaling, and/or power. If detectors are not so located, a developing fire may damage the alarm system, crippling its ability to report a fire.

**Audible warning devices** such as bells may not alert people if these devices are located on the other side of closed or partly open doors or are located on another floor of a building. Any warning device may fail to alert people with a disability or those who have recently consumed drugs, alcohol or medication. Please note that:

- Strobes can, under certain circumstances, cause seizures in people with conditions such as epilepsy.
- Studies have shown that certain people, even when they hear a fire alarm signal, do not respond or comprehend the meaning of the signal. It is the property owner's responsibility to conduct fire drills and other training exercise to make people aware of fire alarm signals and instruct them on the proper reaction to alarm signals.
- In rare instances, the sounding of a warning device can cause temporary or permanent hearing loss.

**A fire alarm system** will not operate without any electrical power. If AC power fails, the system will operate from standby batteries only for a specified time and only if the batteries have been properly maintained and replaced regularly.

**Equipment used in the system** may not be technically compatible with the control panel. It is essential to use only equipment listed for service with your control panel.

**Telephone lines** needed to transmit alarm signals from a premise to a central monitoring station may be out of service or temporarily disabled. For added protection against telephone line failure, backup radio transmission systems are recommended.

**The most common cause** of fire alarm malfunction is inadequate maintenance. To keep the entire fire alarm system in excellent working order, ongoing maintenance is required per the manufacturer's recommendations, and UL and NFPA standards. At a minimum, the requirements of NFPA 72 shall be followed. Environments with large amounts of dust, dirt or high air velocity require more frequent maintenance. A maintenance agreement should be arranged through the local manufacturer's representative. Maintenance should be scheduled monthly or as required by National and/or local fire codes and should be performed by authorized professional fire alarm installers only. Adequate written records of all inspections should be kept.

Limit-C1-2-2007

# Installation Precautions

*Adherence to the following will aid in problem-free installation with long-term reliability:*

**WARNING - Several different sources of power can be connected to the fire alarm control panel.** Disconnect all sources of power before servicing. Control unit and associated equipment may be damaged by removing and/or inserting cards, modules, or interconnecting cables while the unit is energized. Do not attempt to install, service, or operate this unit until manuals are read and understood.

**CAUTION - System Re-acceptance Test after Software Changes:** To ensure proper system operation, this product must be tested in accordance with NFPA 72 after any programming operation or change in site-specific software. Re-acceptance testing is required after any change, addition or deletion of system components, or after any modification, repair or adjustment to system hardware or wiring. All components, circuits, system operations, or software functions known to be affected by a change must be 100% tested. In addition, to ensure that other operations are not inadvertently affected, at least 10% of initiating devices that are not directly affected by the change, up to a maximum of 50 devices, must also be tested and proper system operation verified.

**This system** meets NFPA requirements for operation at 0-49° C/32-120° F and at a relative humidity 93% ± 2% RH (non-condensing) at 32°C ± 2°C (90°F ± 3°F). However, the useful life of the system's standby batteries and the electronic components may be adversely affected by extreme temperature ranges and humidity. Therefore, it is recommended that this system and its peripherals be installed in an environment with a normal room temperature of 15-27° C/60-80° F.

**Verify that wire sizes are adequate** for all initiating and indicating device loops. Most devices cannot tolerate more than a 10% I.R. drop from the specified device voltage.

**Like all solid state electronic devices,** this system may operate erratically or can be damaged when subjected to lightning induced transients. Although no system is completely immune from lightning transients and interference, proper grounding will reduce susceptibility. Overhead or outside aerial wiring is not recommended, due to an increased susceptibility to nearby lightning strikes. Consult with the Technical Services Department if any problems are anticipated or encountered.

**Disconnect AC power and batteries** prior to removing or inserting circuit boards. Failure to do so can damage circuits.

**Remove all electronic assemblies** prior to any drilling, filing, reaming, or punching of the enclosure. When possible, make all cable entries from the sides or rear. Before making modifications, verify that they will not interfere with battery, transformer, or printed circuit board location.

**Do not tighten screw terminals** more than 9 in-lbs. Overtightening may damage threads, resulting in reduced terminal contact pressure and difficulty with screw terminal removal.

**This system contains static-sensitive components.** Always ground yourself with a proper wrist strap before handling any circuits so that static charges are removed from the body. Use static suppressive packaging to protect electronic assemblies removed from the unit.

**Follow the instructions** in the installation, operating, and programming manuals. These instructions must be followed to avoid damage to the control panel and associated equipment. FACP operation and reliability depend upon proper installation.

Precau-D1-9-2005

## FCC Warning

**WARNING:** This equipment generates, uses, and can radiate radio frequency energy and if not installed and used in accordance with the instruction manual may cause interference to radio communications. It has been tested and found to comply with the limits for class A computing devices pursuant to Subpart B of Part 15 of FCC Rules, which is designed to provide reasonable protection against such interference when devices are operated in a commercial environment. Operation of this equipment in a residential area is likely to cause interference, in which case the user will be required to correct the interference at his or her own expense.

## Canadian Requirements

This digital apparatus does not exceed the Class A limits for radiation noise emissions from digital apparatus set out in the Radio Interference Regulations of the Canadian Department of Communications.

Le present appareil numerique n'emette pas de bruits radioelectriques depassant les limites applicables aux appareils numeriques de la classe A prescrites dans le Reglement sur le brouillage radioelectrique edicte par le ministere des Communications du Canada.

**HARSH™, NIS™, Notifier Integrated Systems™, and NOTI-FIRE-NET™** are all trademarks; and **Acclimate® Plus, FlashScan®, NION®, NOTIFIER®, ONYX®, ONYXWorks®, UniNet®, VeriFire®, and VIEW®** are all registered trademarks of Honeywell International Inc. **Echelon®** is a registered trademark and **LonWorks™** is a trademark of Echelon Corporation. **ARCNET®** is a registered trademark of Datapoint Corporation. **Microsoft®** and **Windows®** are registered trademarks of the Microsoft Corporation. **LEXAN®** is a registered trademark of GE Plastics, a subsidiary of General Electric Company.

©Thursday, September 04, 2008 by Honeywell International Inc. All rights reserved. Unauthorized use of this document is strictly prohibited.

## Software Downloads

In order to supply the latest features and functionality in fire alarm and life safety technology to our customers, we make frequent upgrades to the embedded software in our products. To ensure that you are installing and programming the latest features, we strongly recommend that you download the most current version of software for each product prior to commissioning any system. Contact Technical Support with any questions about software and the appropriate version for a specific application.

## Documentation Feedback

Your feedback helps us keep our documentation up-to-date and accurate. If you have any comments or suggestions about our online Help or printed manuals, you can email us.

Please include the following information:

- Product name and version number (if applicable)
- Printed manual or online Help
- Topic Title (for online Help)
- Page number (for printed manual)
- Brief description of content you think should be improved or corrected
- Your suggestion for how to correct/improve documentation

Send email messages to:

**FireSystems.TechPubs@honeywell.com**

Please note this email address is for documentation feedback only. If you have any technical issues, please contact Technical Services.



# Table of Contents

<b>Section 1: About This Manual</b> .....	<b>7</b>
1.1: Standards and Other Documents.....	7
1.2: UL 864 Compliance.....	8
1.2.1: Products Subject to AHJ Approval.....	8
1.3: Related Documents.....	8
1.4: Cautions and Warnings.....	10
<b>Section 2: System Overview</b> .....	<b>11</b>
2.1: System Description.....	11
2.1.1: Standard Features.....	11
2.1.2: Options.....	12
2.1.3: System Limitations.....	12
2.2: System Components.....	12
2.2.1: Basic Equipment.....	12
2.2.2: Control Panel Circuit Board.....	13
2.2.3: Main Power Supply (CPS-24/E).....	13
2.2.4: Circuit Board Components.....	14
2.3: System Cabinets.....	16
2.4: Compatible Equipment.....	17
<b>Section 3: Installation</b> .....	<b>19</b>
3.1: Preparing for Installation.....	19
3.1.1: Standards and Codes.....	19
3.2: Installation Checklist.....	20
3.3: Mounting a Cabinet.....	20
3.4: Laying Out Equipment in Cabinet and Chassis.....	21
3.5: Installing the Control Panel.....	25
3.5.1: Control Panel Circuit Board & Keypad/Display Unit.....	25
3.5.2: Using NCA-2 as Primary Display.....	26
3.6: Mounting Option Boards.....	27
3.6.1: Option Boards in the NFS2-640 Chassis.....	27
3.6.2: Option Boards in CHS-4L.....	28
3.6.3: Option Boards on BMP-1 in Dress Panels.....	29
3.6.4: Transmitter Module TM-4.....	30
3.6.5: Loop Expander Module.....	30
3.6.6: Network Communications Module.....	31
3.6.7: DVC Digital Voice Command.....	32
3.7: Connecting the Power Cables.....	33
3.7.1: Overview.....	33
3.7.2: Connecting the Control Panel to AC Power.....	34
3.7.3: Checking AC Power.....	35
3.7.4: Installing and Connecting the Batteries.....	35
3.7.5: External DC Power Output Connections.....	36
3.7.6: Accessories DC Power Output Connections.....	36
3.8: NAC Connections and Releasing Circuits.....	37
3.9: Output Relay Connections.....	38
3.10: Backup-Alarm Switches.....	38
3.11: UL Power-limited Wiring Requirements.....	39
3.11.1: Labeling Modules and Circuits.....	40
3.12: Installing EIA-485 Devices.....	40
3.13: Installing Remote Printers and/or CRT.....	40
3.13.1: Custom Cable Fabrication.....	40
3.13.2: Installing and Configuring the PRN Series Printer.....	41
3.13.3: Installing and Configuring a Keltron Printer.....	42
3.13.4: Installing and Configuring a CRT-2.....	43

3.13.5: Connecting Multiple Printers, CRTs, or CRT/PRN Combination .....	45
3.14: Wiring a Signaling Line Circuit (SLC).....	45
3.15: Connecting a PC for Off-Line Programming.....	46
<b>Section 4: Applications .....</b>	<b>47</b>
4.1: Overview.....	47
4.2: Devices Requiring External Power Supervision.....	47
4.3: NFPA 72 Central or Remote Station Fire Alarm System (Protected Premises Unit) .....	48
4.4: NFPA 72 Proprietary Fire Alarm Systems.....	49
4.5: Fire/Security Applications .....	50
4.5.1: General Operation.....	50
4.5.2: Installing a Security Tamper Switch.....	50
4.5.3: Receiving Unit .....	51
4.5.4: Programming .....	51
4.5.5: Wiring for Proprietary Security Alarm Applications .....	51
4.6: Releasing Applications .....	52
4.6.1: Overview.....	52
4.6.2: Programming .....	53
4.6.3: Connecting a Releasing Device to the Control Panel.....	53
4.6.4: Connecting a Releasing Device to the FCM-1 Module (Retrofit applications only) .....	55
4.7: Connecting Releasing Devices to the FCM-1-REL Control Module .....	56
4.8: Connecting an NBG-12LRA Agent Release-Abort Station .....	57
<b>Section 5: Testing the System .....</b>	<b>59</b>
5.1: Acceptance Test .....	59
5.2: Periodic Testing and Service.....	59
5.3: Operational Checks .....	59
5.4: Battery Checks and Maintenance.....	60
<b>Appendix A: Power Supply Calculations .....</b>	<b>61</b>
A.1: Calculating AC Branch Circuit Current.....	61
A.2: Calculating the System Current Draws .....	61
A.2.1: Calculating the Maximum Secondary Power Fire Alarm Current Draw.....	63
A.3: Calculating the Battery Requirements .....	65
A.3.1: Calculating the Battery Capacity .....	65
A.3.2: Calculating the Battery Size .....	66
<b>Appendix B: Electrical Specifications .....</b>	<b>67</b>
B.1: Electrical Specifications.....	67
B.2: Wire Requirements.....	69
<b>Appendix C: Canadian Applications.....</b>	<b>71</b>
C.1: Standalone Application .....	71
C.1.1: NFS2-640/E with KDM-R2 .....	71
C.1.2: NFS2-640/E with NCA-2.....	71
C.2: Local Network Application.....	71
C.3: Automatic Alarm Signal Silence.....	71
C.4: Annunciator Applications .....	71
C.5: Releasing Devices .....	71
<b>Index .....</b>	<b>73</b>

# Section 1: About This Manual

## 1.1 Standards and Other Documents



■ **This Fire Alarm Control Panel complies with the following NFPA standards:**

- NFPA 12 CO<sub>2</sub> Extinguishing Systems
- NFPA 12A Halon 1301 Extinguishing Systems
- NFPA 13 Sprinkler Systems
- NFPA 15 Water Spray Systems
- NFPA 16 Foam/Water Deluge and Foam/Water Spray Systems
- NFPA 17 Dry Chemical Extinguishing Systems
- NFPA 17A Wet Chemical Extinguishing Systems
- NFPA 72 Central Station Fire Alarm Systems (Automatic, Manual and Waterflow) Protected Premises Unit (requires Notifier UDACT).
- NFPA 72 Local (Automatic, Manual, Waterflow and Sprinkler Supervisory) Fire Alarm Systems.
- NFPA 72 Auxiliary (Automatic, Manual and Waterflow) Fire Alarm Systems (requires TM-4).
- NFPA 72 Remote Station (Automatic, Manual and Waterflow) Fire Alarm Systems
- NFPA 72 Proprietary (Automatic, Manual and Waterflow) Fire Alarm Systems (Protected Premises Unit).
- NFPA 2001 Clean Agent Fire Extinguishing Systems

■ **The installer should be familiar with the following documents and standards:**

- NFPA 72 Initiating Devices for Fire Alarm Systems
- NFPA 72 Inspection, Testing and Maintenance for Fire Alarm Systems
- NFPA 72 Notification Appliances for Fire Alarm Systems

**Underwriters Laboratories**



- UL 38 Manually Actuated Signaling Boxes
- UL 217 Smoke Detectors, Single and Multiple Station
- UL 228 Door Closers - Holders for Fire Protective Signaling Systems
- UL 268 Smoke Detectors for Fire Protective Signaling Systems
- UL 268A Smoke Detectors for Duct Applications
- UL 346 Waterflow Indicators for Fire Protective Signaling Systems
- UL 464 Audible Signaling Appliances
- UL 521 Heat Detectors for Fire Protective Signaling Systems
- UL 864 Standard for Control Units for Fire Protective Signaling Systems
- UL 1481 Power Supplies for Fire Protective Signaling Systems
- UL 1971 Visual Signaling Appliances
- UL 1076 Proprietary Burglar Alarm Systems
- UL 2017 Standard for general-Purpose Signaling Devices and Systems
- UL 60950 Safety of Information Technology Equipment

**Underwriters Laboratories of Canada (ULC)**



- Standard CAN/ULC-S527-M99
- CAN/ULC-S524-M91 Standard for the Installation of Fire Alarm Systems

**Other**

- EIA-485 and EIA-232 Serial Interface Standards
- NEC Article 300 Wiring Methods
- NEC Article 760 Fire Protective Signaling Systems
- Applicable Local and State Building Codes
- Requirements of the Local Authority Having Jurisdiction

## 1.2 UL 864 Compliance

### 1.2.1 Products Subject to AHJ Approval

This product has been certified to comply with the requirements in the Standard for Control Units and Accessories for Fire Alarm Systems, UL 864 9th Edition.

The following products have not received UL 864 9th Edition certification and may only be used in retrofit applications. Operation of the NFS2-640/E with products not tested for UL 864 9th Edition has not been evaluated and may not comply with NFPA 72 and/or the latest edition of UL 864. These applications will require the approval of the local Authority Having Jurisdiction (AHJ).

- For a complete list of all peripherals that can be used with this fire alarm control panel (FACP), and which of those peripherals have not received UL 864, 9th Edition certification and may only be used in retrofit applications, see Section 2.4, “Compatible Equipment”, on page 17.

## 1.3 Related Documents

Table 1.1 below provides a list of documents referenced in this manual, as well as documents for selected other compatible devices. The document series chart (DOC-NOT) provides the current document revision. A copy of this document is included in every shipment.

<b>Compatible Conventional Devices (Non-addressable)</b>	<b>Document Number</b>
Device Compatibility Document	15378
<b>Fire Alarm Control Panel (FACP) and Main Power Supply Installation</b>	<b>Document Number</b>
NFS2-640/E Installation, Operations, and Programming Manuals	52741, 52742, 52743
DVC and DAA Digital Audio Series Manual	52411
SLC Wiring Manual	51253
Note: For individual SLC Devices, refer to the <i>SLC Wiring Manual</i>	
<b>Off-line Programming Utility</b>	<b>Document Number</b>
VeriFire® Tools CD help file	VERIFIRE-TCD
<b>Cabinets &amp; Chassis</b>	<b>Document Number</b>
CAB-3/CAB-4 Series Cabinet Installation Document	15330
Battery/Peripherals Enclosure Installation Document	50295
<b>Power Supplies, Auxiliary Power Supplies &amp; Battery Chargers</b>	<b>Document Number</b>
ACPS-2406 Installation Manual	51304
ACPS-610 Installation Manual	53108
APS-6R Instruction Manual	50702
CHG-120 Battery Charger Manual	50641
FCPS-24 Field Charger/Power Supply Manual	50059
FCPS-24S6/FCPS-24S8 Field Charger/Power Supply Manual	51977
<b>Networking</b>	<b>Document Number</b>
Noti•Fire•Net Manual, Network Version 5.0 & Higher	51584

**Table 1.1 Reference Documentation (1 of 2)**

NCM-W/F Installation Document	51533
ONYXWorks™ Workstation Hardware & Software Application: Installation and Operation Manual	52342
ONYXWorks™ NFN Gateway (PC Platform) Installation & Operation Manual	52307
ONYXWorks™ NFN Gateway (Embedded Platform) Installation & Operation Manual	52306
NCS ONYX® Network Control Station Manual, Network Version 5.0 & Higher	51658
NCA-2 Network Control Annunciator Manual	52482
NCA Network Control Annunciator Manual	51482
<b>System Components</b>	<b>Document Number</b>
Annunciator Control System Manual	15842
ACM-8R Annunciator Control Module Manual	15342
FDU-80 Remote Annunciator Manual	51264
LCD-80 Manual	15037
LDM Series Lamp Driver Annunciator Manual	15885
SCS Smoke Control Manual (Smoke and HVAC Control Station)	15712
DPI-232 Direct Panel Interface Manual	51499
TM-4 Installation Document (Reverse Polarity Transmitter)	51490
UDACT Manual (Universal Digital Alarm Communicator/Transmitter)	50050
AA-Series Audio Amplifiers Manual	52526
ACT-1 Installation Document	52527
ACT-2 Installation Document	51118
FireVoice-25/50 & FireVoice-25/50ZS Manual	52290
RM-1 Series Remote Microphone Installation Document	51138
RA400Z Remote LED Annunciator Installation Document	I56-508
XP Transponder Manual	15888
XP10-M Installation Document	I56-1803
XP5 Series Manual	50786
XP6-C Installation Document	I56-1805
XP6-MA Installation Document	I56-1806
XP6-R Installation Document	I56-1804
XPIQ Audio Transponder Manual	51013

**Table 1.1 Reference Documentation (2 of 2)**



## 1.4 Cautions and Warnings

This manual contains cautions and warnings to alert the reader as follows:

**CAUTION:**

Information about procedures that could cause programming errors, runtime errors, or equipment damage.

---

**WARNING:**

Indicates information about procedures that could cause irreversible damage to the control panel, irreversible loss of programming data or personal injury.

---

# Section 2: System Overview

## 2.1 System Description

The NFS2-640/E control panel is a modular, intelligent fire alarm control panel (FACP) with an extensive list of powerful features. The control panel uses the CPS-24/E power supply with integral battery charger. This is combined with a mounting chassis and cabinet to create a complete fire alarm control system. The panel supports FlashScan® protocol and has network capabilities. A single SLC loop is supported with the basic equipment package; a second SLC loop can be added by attaching an optional loop expander module (LEM-320).

Modular devices mount to the chassis to provide additional output circuits, including voice and telephone modules to form a complete voice evacuation system. Five cabinet options are available for enclosing system components; each is available in red or black.

The control panel has the capacity for installing up to 636 addressable points; 159 detectors and 159 monitor/control modules per SLC (Signaling Line Circuit).

### 2.1.1 Standard Features

- Uses Notifier's VIEW® early warning fire detection and the FlashScan® or Classic Loop Interface Protocol (CLIP) families of detectors and modules
- Four standard Notification Appliance Circuits (NAC), Class A or B
- Alarm, Trouble, Supervisory and Security relays
- Support for 32 annunciator addresses, with 10 special annunciator groups
- Supports Style 4, Style 6, Style 7 SLC loops
- Connections to easily mount an expander board to add a second SLC loop
- Releasing service using on-board NACs or FCM-1 modules
- Logic Equations
- Display scroll selection
- Alarm verification supervisory indication (NYC)
- Supervisory duct detectors
- Supports Advanced Warning Addressable Combustion Sensing (AWACS) algorithms
- Network operation
- Battery charger supports 18 to 200 amp hour sealed lead-acid batteries
- EIA-485 connections for wiring ACS annunciators (including LDM custom graphic annunciators), TM-4 transmitter
- EIA-232 connections for printer, CRT, printer/CRT, or network operation
- Autoprogram feature for faster programming of new devices
- The control panel provides 6 amps of usable output power in an alarm condition; it provides 3 amps of usable output power in normal or continuous operating conditions
- Diagnostic LEDs and switches
- Ground fault detection (0 ohm impedance)
- Battery and battery-charger supervision, voltage-monitoring, and current-monitoring
- Programmable for strobe synchronization

## 2.1.2 Options

Refer to Section 2.4 “Compatible Equipment” for other peripherals listed for use with this panel.

- QWERTY silicone-rubber keypad with a 2x40 LCD display and eight indicator LEDs
- Optional LEM-320 provides a second SLC loop that is electrically identical to the one on the main board
- Optional devices include: UDACT Universal Digital Alarm Communicator/Transmitter, ACM-8R remote relay module to increase point capacity, and audio and voice components.
- Optional annunciators connected through the EIA-485 interface allow remote system monitoring.

## 2.1.3 System Limitations

System expansion must take into consideration the following:

1. The physical limitations of the cabinet configuration.
2. The electrical limitations of the system power supply.
3. The capacity of the secondary power source (standby batteries). (Note that batteries larger than 26 AH will require a separate battery backbox.)

## 2.2 System Components

### 2.2.1 Basic Equipment

A basic NFS2-640/E system has the following components:

1. The control panel and power supply. CPU2-640 (120V operation) or CPU2-640E (240V operation) is the “control panel” itself and the heart of the system; it ships with a grounding cable, battery interconnect cables, and document kit. It includes power supply CPS-24/E, mounted directly on the CPU2-640/E.
2. One or more chassis. The NFS2-640 chassis (included with the CPU) mounts the CPU2-640/CPU2-640E and peripherals. Mount additional rows of equipment in a compatible chassis selected from Table 3.3 on page 24.
3. *Optional:* A primary display. Generally this is a KDM-R2 keypad/display behind a DP-DISP2 or ADP2-640 dress panel. For information on using NCA-2 as primary display instead of KDM-R2, see Section 3.5.2 “Using NCA-2 as Primary Display” and the *NCA-2 Manual*.
4. A backbox and door:  
SBB-A4 and DR-A4 (one row of equipment) or  
SBB-B4 and DR-B4 (two rows of equipment) or  
SBB-C4 and DR-C4 (three rows of equipment) or  
SBB-D4 and DR-D4 (four rows of equipment)  
(For a solid-metal door add “B” to the part number; for a red door add “R”.)
5. A battery dress panel BP2-4 is required.
6. Batteries (Refer to Appendix A.3 “Calculating the Battery Requirements” for system current-draw calculations; CAB-4 series backboxes holds batteries up to 26 AH maximum.)

Refer to Section 2.4, “Compatible Equipment” for other peripherals listed for use with this FACP.

## 2.2.2 Control Panel Circuit Board

The control panel electronics are contained on one printed circuit board that incorporates a signaling line circuit (SLC) and the central processing unit (CPU). The built-in power supply includes an integral battery charger. A keypad/display unit can be installed over the power supply; see Figure 2.1. Wiring connections and system components are detailed in Figures 2.2 and 2.3.

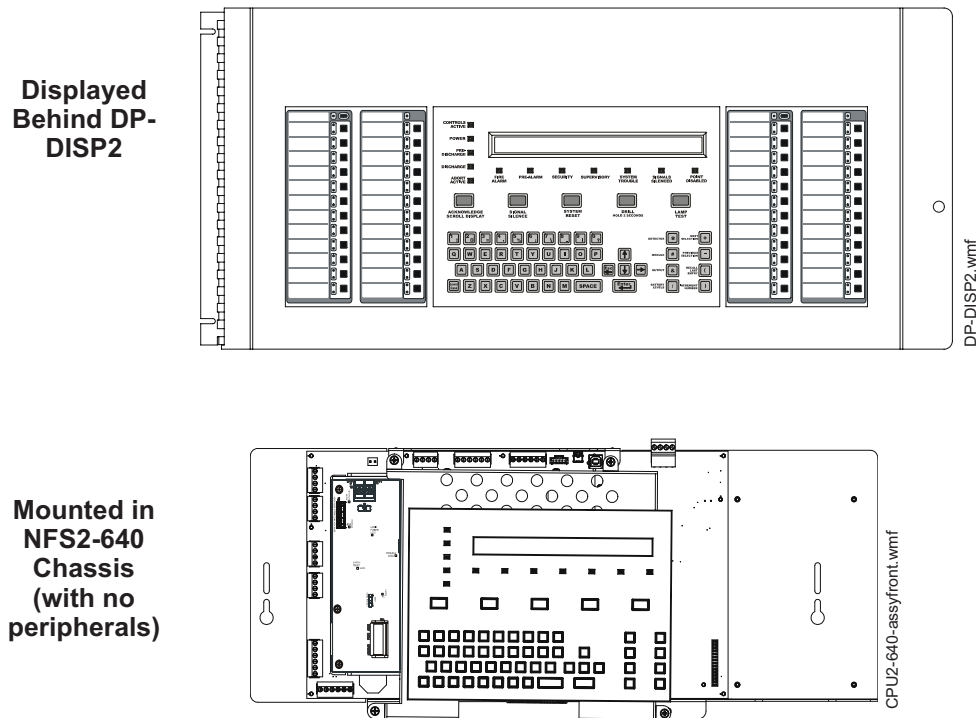


Figure 2.1 NFS2-640/E Control Panel with Optional Keypad/Display Unit Installed

## 2.2.3 Main Power Supply (CPS-24/E)

The main power supply mounts directly over the control panel's circuit board. It provides a total of 3 A (6 A in alarm) and contains an integral battery charger. This can be used for many functions including:

- Powering the NFS2-640/E
- Powering a variety of UL-listed 24 VDC notification appliances from four built-in NAC outputs
- Providing up to 1.25 A of resettable power for four-wire smoke detectors
- Providing up to 1.25 A of non-resettable power for external devices such as the TM-4 Transmitter Module.
- Providing auxiliary 24 VDC power @ 0.5A and 5 VDC power @ 0.15A.

See Figure 2.2, "CPU2-640/CPU2-640E and Power-Supply: Wiring Connections" and Figure 2.3, "CPU2-640/CPU2-640E and Power-Supply: Jumpers, LEDs and Switches" for details.

## 2.2.4 Circuit Board Components

The following two figures illustrate the location of the various connections, switches, jumpers and LEDs on the CPU2-640/CPU2-640E and its power supply. Figure 2.2 shows wiring connections; Figure 2.3 shows jumpers, LEDs and switches. See Section 3 “Installation” for larger images and more details. (Larger images are referenced on these drawings.)

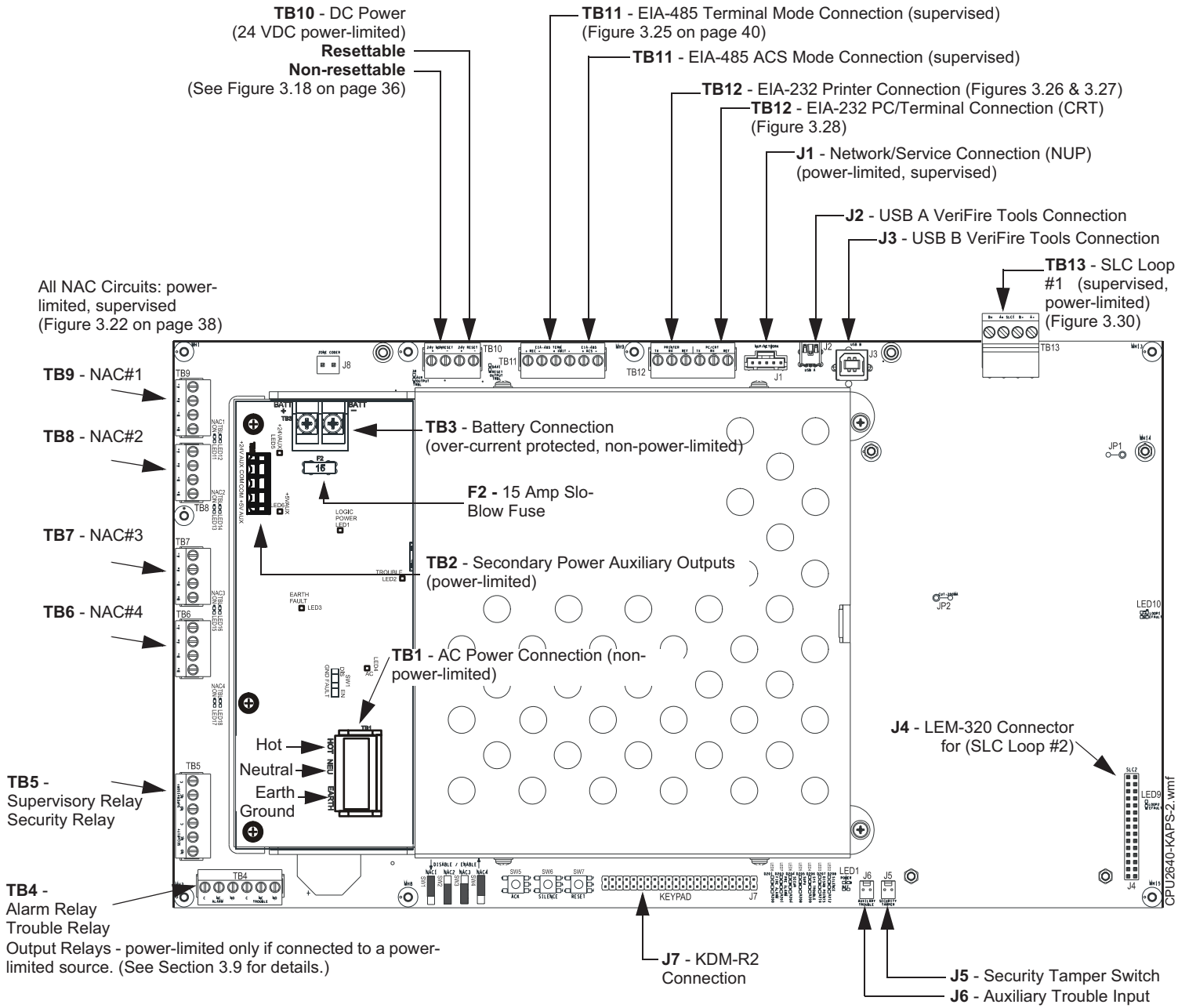


Figure 2.2 CPU2-640/CPU2-640E and Power-Supply: Wiring Connections



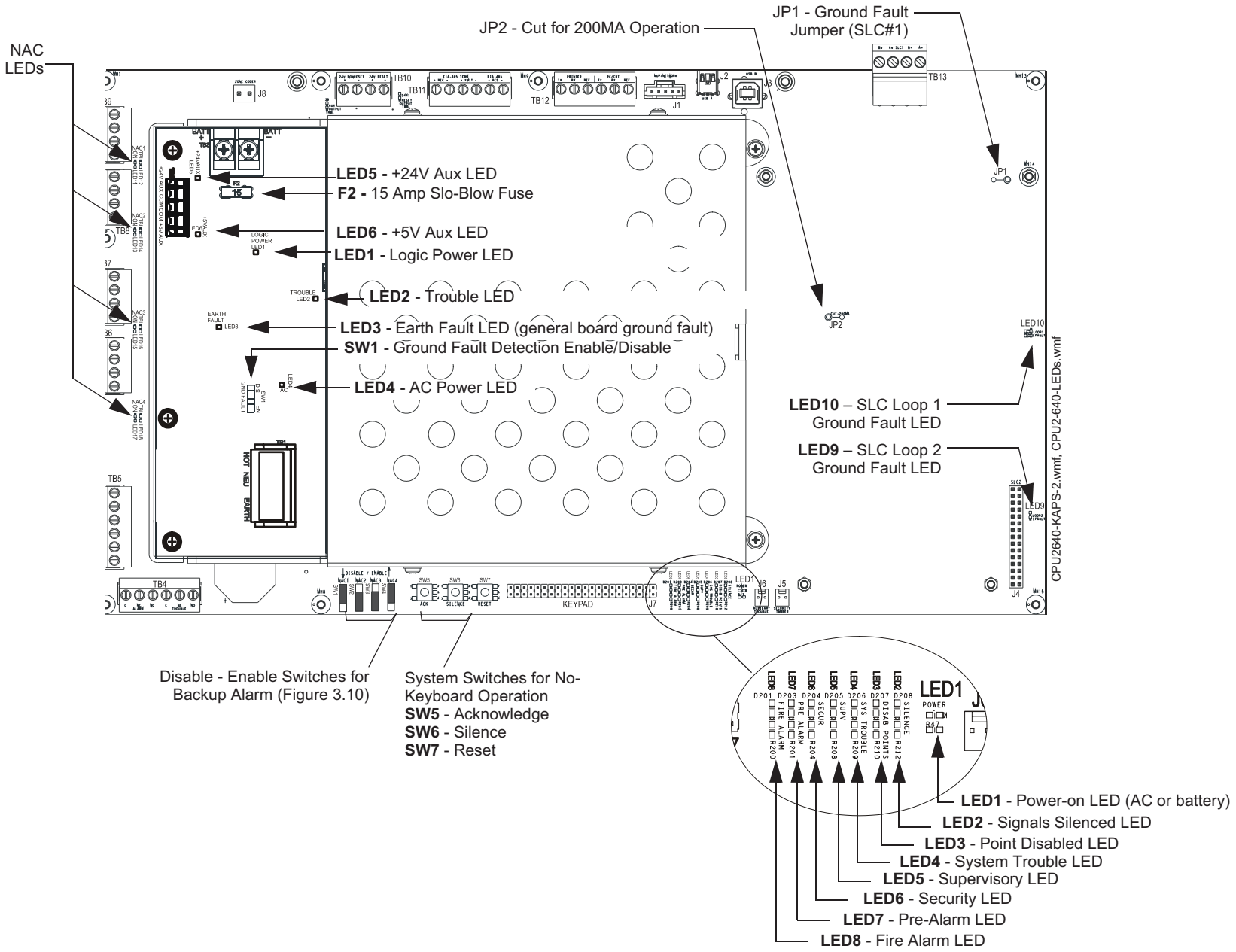


Figure 2.3 CPU2-640E and Power-Supply: Jumpers, LEDs and Switches

## 2.3 System Cabinets

The control panel and modules are installed in a CAB-4 series backbox. There are four different sizes available, holding from one to four rows of equipment plus batteries (up to two 26 AH batteries). Backboxes are ordered separately from doors. The doors can be mounted on the left or the right side of the cabinet; reversible hinges are provided so that this choice can be made in the field. Doors open a full 180 degrees and have locks. Mounting methods include surface-mounting or semi-flush mounting on a wall between 16 inch (40.64 cm) on-center studs. A trim ring option is available for semi-flush mounting.

External measurements for each backbox are provided below; door dimensions are larger. Refer to *CAB-3/CAB-4 Series Cabinet Installation Document* (shipped with the cabinet) for specific mounting drawings and door dimensions.

<b>A-size backbox (one row)</b>	24.00 in (60.96 cm) wide 20.00 in (50.8 cm) tall 5.218 in (13.254 cm) deep Uses optional trim ring TR-A4	<b>Optional trim ring TR-A4</b> Opening: 24.062 in (61.118 cm) wide; 20.062 in (50.881 cm) tall. Molding width: 1.375 in (3.493 cm)
<b>B-size backbox (two rows)</b>	24.00 in (60.96 cm) wide 28.5 in (72.39 cm) tall 5.218 in (13.254 cm) deep Uses optional trim ring TR-B4	<b>Optional trim ring TR-B4</b> Opening: 24.062 in (61.118 cm) wide; 28.562 in (72.548 cm) tall. Molding width: 1.375 in (3.493 cm)
<b>C-size backbox (three rows)</b>	24.00 in (60.96 cm) wide 37.125 in (94.297 cm) tall 5.218 in (13.254 cm) deep Uses optional trim ring TR-C4	<b>Optional trim ring TR-C4</b> Opening: 24.062 in (61.118 cm) wide; 37.187 in (94.455 cm) tall. Molding width: 1.375 in (3.493 cm)
<b>D-size backbox (four rows)</b>	24.00 in (60.96 cm) wide 45.75 in (1162.05 cm) tall 5.218 in (13.254 cm) deep Uses optional trim ring TR-D4	<b>Optional trim ring TR-D4</b> Opening: 24.062 in (61.118 cm) wide; 45.812 in (114.775 cm) tall. Molding width: 1.375 in (3.493 cm)
<b>Trim Rings:</b> When using trim rings, mount backbox with at least 1 inch (2.54 cm) between wall surface and front of backbox, to allow door to open fully past the trim ring.		

**Table 2.1 Backbox Measurements**

For details on mounting options within the cabinet, see Section 3.4, “Laying Out Equipment in Cabinet and Chassis”.

## 2.4 Compatible Equipment

These are the most common devices at time of publishing; the most complete list of compatible intelligent SLC loop devices is provided in the *SLC Wiring Manual*; for conventional non-addressable equipment see the *Device Compatibility Document*. These devices are UL and ULC listed unless marked otherwise (in parentheses next to the product). Other control panels and their equipment can also be connected in a network, via Noti•Fire•Net version 5.0; refer to the *Noti•Fire•Net Version 5.0 & Higher Installation Manual*. For products documented separately, see Section 1.3 “Related Documents”.



### WARNING: UL 9th Edition Compliance

This product has been certified to comply with the requirements in the Standard for Control Units and Accessories for Fire Alarm Systems, UL 864 9th Edition. Operation of the NFS2-640/E with products not tested for UL 864 9th Edition has not been evaluated and may not comply with NFPA 72 and/or the latest edition of UL 864. These applications will require the approval of the local Authority Having Jurisdiction (AHJ).

Peripheral devices in the second list were listed under UL 8th Edition and may only be used in retrofit applications (see Section 1.2, “UL 864 Compliance”, on page 8).

### Notifier Compatible Equipment

NOTE: Products marked with a checkmark “✓” have not received UL 864 9th Edition certification and may only be used in retrofit applications (see Section 1.2, “UL 864 Compliance”, on page 8).

#### Electronic Equipment

**AA-30** 30-Watt Audio Amplifier  
**AA-100** 100-Watt Audio Amplifier  
**AA-120** 120-Watt Audio Amplifier  
**ACM-24AT** Annunciator Control Module  
**ACM-48A** Annunciator Control Module  
**ACM-8R** Annunciator Control Module  
**ACPS-610** Addressable Charger/Power Supply  
**ACT-1** Audio Coupling Transformer  
**ACT-2** Audio Coupling Transformer  
**AEM-24AT** Annunciator Expander Module  
**AEM-48A** Annunciator Expander Module  
**AKS-1B** Annunciator Key Switch  
**APJ-1B** Annunciator Phone Jack  
**BAT-12120** Battery 12-volt, 12 amp-hour  
**BAT-12180** Battery 12-volt, 18 amp-hour  
**BAT-12250** Battery 12-volt, 25 amp-hour  
**BAT-12260** Battery 12-volt, 26 amp-hour  
**BAT-12550** Battery 12-volt, 55 amp-hour  
**BAT-12600** Battery 12-volt, 60 amp-hour  
**BX-501** Intelligent Detectors/Sensors Base  
**B501** Intelligent base  
**B501BH** Sounder base  
**B710LP** Intelligent detector base  
**CCM-1** Communication Converter Module  
**CMX-1** Addressable Control Module  
**CMX-2** Addressable Control Module  
**CPU2-640/E** Control Panel Circuit Board  
**CPX-551** Ionization Smoke Detector  
**CPX-751** Intelligent Ionization Smoke Detector  
**CRT-2** Video Display Monitor with Keyboard  
**DPI-232** Direct Panel Interface  
**DAA** Digital Audio Amplifier  
**DVC-EM** Digital Voice Command Extended Memory  
**DVC-AO** Digital Voice Command Audio Output  
**FCM-1** NAC Module  
**FCM-1-REL** Control Module  
**FCPS-24S6/S8** Field Charger Power Supply  
**FDX-551** Intelligent Thermal Sensor  
**FDU-80, FDU-80G** Remote Fire Annunciator  
**FHS** Fireman’s Handset  
**FMM-1** Monitor Module

**FMM-101** Mini Monitor Module  
**FSC-851** IntelliQuad Multi-Criteria Smoke Detector  
**FSB-200S** Single-ended beam smoke detector with sensitivity testing  
**FSB-200** Single-ended beam smoke detector.  
**FSD-751P** Photoelectric Duct Detector  
**FSD-751RP** Photoelectric Duct Detector with alarm relay  
**FSD-751PL** Low-flow Duct Detector  
**FSD-751RPL** Low-flow Duct Detector with alarm relay  
**DHX-501, DHX-502** Duct Detectors  
**FSI-751, FSI-851** Ion Detector  
**Acclimate Plus™ FAPT-751, FAPT-851**  
 Combination Photoelectric/Heat Detector  
**FSH-751 HARSH™** Smoke Detector  
**HPX-751** Intelligent HARSH™ Detector  
**FSL-751 VIEW®** Low Profile Laser Detector  
**FSM-101** Pull Station Monitor Module  
**FPJ** Firefighter’s Phone Jack  
**FRM-1** Relay Module  
**FSP-751, FSP-851** Photo Detector  
**FSP-751T, FSP-851T** Photo/Thermal Detector  
**FST-751, FST-851** Thermal Detector  
**FST-751R, FST-851R** Thermal Detector (rate of rise)  
**FST-851H High Temperature Detector**  
**FTM-1** Telephone Module  
**FZM-1** Monitor and Zone Interface Module  
**FDM-1** Dual Monitor Module  
**ISO-X** Loop Fault Isolator Module  
**KDM-R2** Keypad/Display Unit  
**LCD-80** Liquid Crystal Display Annunciator  
**LDM-32** Lamp Driver Module  
**LDM-E32** Lamp Driver Module  
**LDM-R32** Lamp Driver Module  
**LEM-320** Loop Expander Module  
**LPX-751 VIEW®** Low Profile Laser Detector (CLIP)  
**MMX-1** Addressable Monitor Module  
**MMX-2** Addressable Monitor Module  
**MMX-101** Addressable Mini Monitor Module  
**NBG-12LRA** Agent Release-Abort Station  
**NBG-12 Series** Manual Pull Station

*Continued on next page...*

**NBG-12LX** Addressable Manual Pull Station  
**NBG-12LXP** Portuguese-labeled Addressable Manual Pull Station  
**NBG-12LXSP** Spanish-labeled Addressable Manual Pull Station  
**NCA-2** Network Control Annunciator  
**NCM-F** Network Communications Module (Fiber)  
**NCM-W** Network Communications Module (Wire)  
**NCS** Network Control Station  
**NFV-25/50** Notifier FireVoice-25/50  
**N-ELR** Assortment ELR Pack with Mounting Plate  
**ONYXWorks** Graphical Workstation  
**PRN-6** 80-Column Printer  
**R-120** 120 Ohm End-of-Line Resistor  
**R-2.2K** 2.2K End-of-Line Resistor  
**R-27K** 27K End-of-Line Resistor  
**R-470** 470 End-of-Line Resistor  
**R-47K** 47K End-of-Line Resistor  
**A77-716B** End-of-Line Resistor Assembly

#### Backboxes, Chassis, Dress Panels, etc.

**ABF-1B** Annunciator Flush Box  
**ABF-1DB** Annunciator Flush Box with Door  
**ABF-2B** Annunciator Flush Box  
**ABF-2DB** Annunciator Flush Box with Door  
**ABF-4B** Annunciator Flush Box  
**ABM-16AT** Annunciator Blank Module  
**ABM-32A** Annunciator Module Blank  
**ABS-1TB** Annunciator Surface Box  
**ABS-1B** Annunciator Surface Box  
**ABS-2B** Annunciator Surface Box  
**ABS-4D** Annunciator Surface Box  
**ABS-8RB** Annunciator Backbox for ACM-8R  
**ADP2-640** Dress Panel: NFS2-640/E in lower row  
**ADP-4B** Annunciator Dress Panel  
**BMP-1** Blank Module Plate  
**BP2-4** Battery Dress Plate  
**CAB-4 Series Doors (Black unless “R” is added to the P/N. Add B to the P/N for blank door)**  
**DR-A4** A-sized door, 1 row of equipment  
**DR-B4** B-sized door, 2 rows of equipment  
**DR-C4** C-sized door, 3 rows of equipment  
**DR-D4** D-sized door, 4 rows of equipment

#### System Sensor Equipment

**A2143-00** End of Line Resistor Assembly  
**EOLR-1** End-of-Line Resistor Assembly

**RPJ-1** Fireman's Phone Jack  
**RPT-485F** EIA-485 Repeater (Fiber)  
**RPT-485W** EIA-485 Repeater (Wire)  
**RPT-485WF** EIA-485 Repeater (Wire/Fiber)  
**RM-1** Remote Microphone  
**RM-1SA** Remote Microphone  
**SCS-8, SCE-8** Smoke Control Station  
**SCS-8L, SCE-8L** Smoke Control Lamp Driver  
**SDX-551** Intelligent Photoelectric Detector  
**SDX-751** Intelligent Photoelectric Detector  
**STS-1** Security Tamper Switch  
**TM-4** Transmitter Module  
**UDACT** Universal Digital Alarm Communicator Transmitter  
**XPIQ** Quad Intelligent Audio Transponder  
**XP6-C** Supervised Control Module  
**XP6-R** Six Relay Control Module  
**XP6-MA** Six Zone Interface Module  
**XP10-M** Ten Input Monitor Module

#### CAB-4 Series Backboxes (Black unless “R” is added to the P/N.)

**SBB-A4** A-sized backbox  
**SBB-B4** B-sized backbox  
**SBB-C4** C-sized backbox  
**SBB-D4** D-sized backbox  
**CAB-4 Series Trim Rings (Black unless “R” is added to the P/N)**  
**TR-A4** A-sized trim ring  
**TR-B4** B-sized trim ring  
**TR-C4** C-sized trim ring  
**TR-D4** D-sized trim ring  
**CHS-4L** Low-Profile Chassis  
**CHS-4, CHS-4N** Chassis for 4 Option Boards  
**NFS2-640 Chassis** for 1st row (included in basic equipment package)  
**DP-1B** Blank Dress Plate  
**DP-DISP2** Dress Panel: NFS2-640/E in top row  
**DPDW-1B** Double Well Dress Plate  
**DPSW-1B** Single Well Dress Plate  
**NFS-LBB** Battery Box  
**NFS-LBBR** Red Battery Box  
**VP-2B** 2” Filler Dress Plate

**FSB-200, FSB-200S** Beam Detectors

#### Retrofit Equipment: Compatible Notifier Equipment Listed Under Previous Editions of UL 864

NOTE: The products in this list have not received UL 864 9th Edition certification and may only be used in retrofit applications (see Section 1.2, “UL 864 Compliance”, on page 8).

✓ **ACM-16AT** Annunciator Control Module  
 ✓ **ACM-32A** Annunciator Control Module  
 ✓ **ACPS-2406** Auxiliary Charger/Power Supply  
 ✓ **AEM-16AT** Annunciator Expander Module  
 ✓ **AEM-32A** Annunciator Expander Module  
 ✓ **APS-6R** Auxiliary Power Supply  
 ✓ **AMG-1** Audio Message Generator  
 ✓ **AMG-E** Audio Message Generator  
 ✓ **AVL-1** Audio Voice Link (*Not ULC-listed*)  
 ✓ **BGX-101L** Addressable Manual Pull Station  
 ✓ **CHG-120** Battery Charger  
 ✓ **FCPS-24** Field Charger Power Supply  
 ✓ **FFT-7** Fire Fighters Telephone  
 ✓ **FFT-7S** Fire Fighters Telephone  
 ✓ **IPX-751** Advanced Multi-Sensor Intelligent Detector  
 ✓ **NCA** Network Control Annunciator  
 ✓ **P-40** Keltron Printer  
 ✓ **P40-KITB** Dress plate for Keltron Printer  
 ✓ **PRN-4, PRN-5** 80-Column Printers  
 ✓ **RA400** Remote Annunciator  
 ✓ **RA400Z** Remote Annunciator with diode  
 ✓ **XP5-C** Transponder Control Module  
 ✓ **XP5-M** Transponder Monitor Module  
 ✓ **XPC-8** Transponder Control Module  
 ✓ **XPDP** Transponder Dress Panel  
 ✓ **XPM-8** Transponder Monitor Module  
 ✓ **XPM-8L** Transponder Monitor Module  
 ✓ **XPP-1** Transponder Processor  
 ✓ **XPR-8** Transponder Relay Module

# Section 3: Installation

## 3.1 Preparing for Installation

Choose a location for the fire alarm system that is clean, dry, and vibration-free with moderate temperature. The area should be readily accessible with sufficient room to easily install and maintain it. There should be sufficient space for cabinet door(s) to open completely.

Carefully unpack the system and inspect for shipping damage. Count the number of conductors needed for all devices and find the appropriate knockouts. (Refer to Section 3.11 “UL Power-limited Wiring Requirements” for selection guidelines.)

Before installing the fire alarm system, read the following:

- Review the installation precautions at the front of this manual, including temperature and humidity limits for the system (Page 3).
- All wiring must comply with the National and Local codes for fire alarm systems.
- Do not draw wiring into the bottom 9 inches (22.86 cm) of the cabinet except when using a separate battery cabinet; this space is for internal battery installation.
- Review installation instructions in Section 3.2 “Installation Checklist”.



**CAUTION:**

Make sure to install system components in the sequence listed below. Failure to do so can damage the control panel and other system components.

---



**WARNING:**

This system contains static-sensitive components. Always ground yourself with a proper wrist strap before handling any circuits. Use static-suppressive packaging to protect electronic assemblies removed from the unit.

---

### 3.1.1 Standards and Codes

In addition, installers should be familiar with the following standards and codes:

- NEC Article 300 Wiring Methods.
- NEC Article 760 Fire Protective Signaling Systems.
- Applicable Local and State Building Codes.
- Requirements of the Local Authority Having Jurisdiction.
- C22.1-98 The Canadian Electrical Code, Part 1.
- CAN/ULC-S5524-01 Standard for the Installation of Fire Alarm Systems.



## 3.2 Installation Checklist

Table 3.1 provides an installation checklist for installing, wiring, and testing the NFS2-640/E system. It has references to installation information included in manuals listed in Section 1.3 “Related Documents”.

Seq	Task	Refer to
1.	Mount the cabinet backbox to the wall.	Section 3.3 “Mounting a Cabinet”
2.	Install hinges for door	<i>CAB-3/CAB-4 Series Cabinet Installation Document</i>
3.	Install all required chassis in cabinet.	Section 3.5 “Installing the Control Panel”
4.	Install control panel onto chassis.	Section 3.5.1 “Control Panel Circuit Board & Keypad/Display Unit”
5.	Optional: Install auxiliary power supply and/or external battery charger	Auxiliary power manuals
6.	Connect AC wiring, place batteries into backbox without connecting them, and run cable to optional power supplies, DC power outputs, NACs, and relays. <b>CAUTION: Do not apply AC or DC power at this time.</b>	Section 3.7 “Connecting the Power Cables”
7.	Set switches for backup alarm (SW1-SW4).	Section 3.10 “Backup-Alarm Switches”
8.	Optional: Install option boards, annunciators, network equipment, and Audio components	Section 3.6, “Mounting Option Boards”, the relevant annunciator/network-card manual, <i>DVC Manual</i> , and <i>DAA Manual</i> .
9.	Optional: Install output devices such as a printer, or CRT terminal.	Section 3.13 “Installing Remote Printers and/or CRT”
10.	Optional: Install NCA-2 or NCS.	<i>NCA-2 Manual</i> or <i>NCS Manual</i>
11.	Secure any unused mounting holes in control panel circuit board.	Figure 3.8
12.	Wire the Signaling Line Circuits.	Section 3.14 “Wiring a Signaling Line Circuit (SLC)”
13.	Terminate wire shielding as instructed.	SLC Wiring Manual
14.	Apply AC power to the control panel by placing the external circuit breaker to the ON position. <b>Do NOT connect batteries.</b>	
15.	Check AC power.	Table 3.5 in Section 3.7 “Connecting the Power Cables”
16.	Connect the batteries using interconnect cable, P/N 75560 and 75561.	
17.	Install the CAB-4 series door.	<i>CAB-3/CAB-4 Series Cabinet Installation Document</i>
18.	Program the control panel.	<i>NFS2-640/E Programming Manual</i>
19.	Field test the system.	Section 5 “Testing the System”

**Table 3.1 Installation Checklist**

## 3.3 Mounting a Cabinet

This section provides instructions for mounting a CAB-4 Series backbox to a wall. Follow these guidelines when mounting the backbox:

- Locate the backbox so that the top edge is 66 inches (1.6764 m) above the surface of the finished floor.
- Access to the cabinet shall be provided in accordance with NFPA 90, article 110.33.
- Allow sufficient clearance around cabinet for door to swing freely. (See Section 2.3 “System Cabinets”.)
- Use the four holes in the back surface of the backbox to provide secure mounting. (See Figure 3.1.)
- Mount the backbox on a surface that is in a clean, dry, vibration-free area.



**CAUTION:**

Unless you are familiar with the placement of components within this backbox, only use the knockout locations provided for conduit entry.

Follow the instructions below.

1. Mark and pre-drill holes for the top two keyhole mounting bolts (0.25 inch, 0.635 cm). Use mounting hardware appropriate for the mounting surfaces and weight of loaded cabinet; see UL 2017 Pull-Test Requirements.
2. Select and punch open the appropriate knock-outs. (For selection guidelines, see Section 3.11 “UL Power-limited Wiring Requirements”.)
3. Using the keyholes, mount the backbox over the two screws.
4. Mark the location for the two lower holes, remove the backbox and drill the mounting holes.
5. Mount the backbox over the top two screws, then install the remaining fasteners. Tighten all fasteners securely.
6. Feed wires through appropriate knockouts.
7. Install control panel and other components according to Section 3.5 “Installing the Control Panel” before installing hinges and door according to *CAB-3/CAB-4 Series Cabinet Installation Document*.

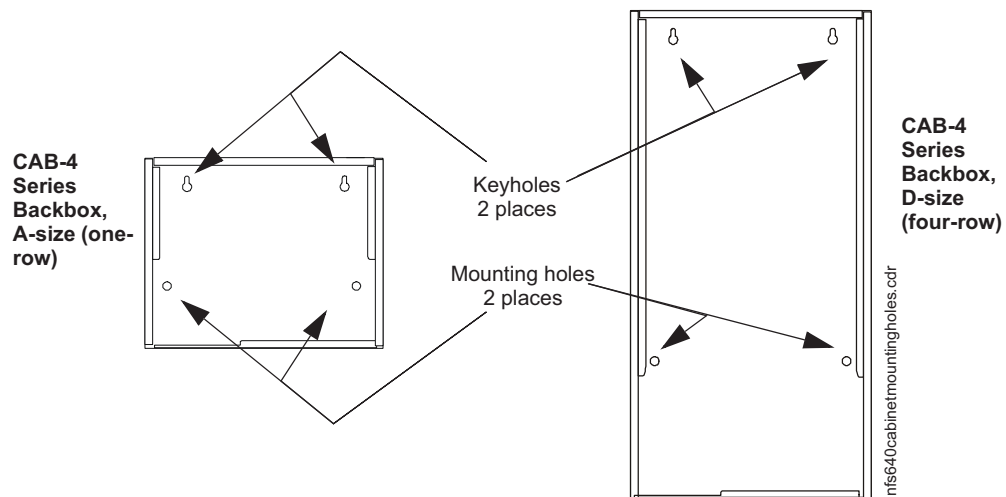


Figure 3.1 Mounting Holes of a Backbox

### 3.4 Laying Out Equipment in Cabinet and Chassis

The NFS2-640/E allows for flexible system design. Backboxes are available to hold up to four rows of equipment (four chassis), plus batteries. Each chassis has four “slots” -- the basic positions available side by side on a chassis. The number of modules that can be mounted in each position depends on the chassis model and the module size.

Follow these guidelines when deciding where to locate equipment in the backbox.

The NFS2-640/E control panel and adjacent first-row modules mount in the NFS2-640 chassis, typically installed in the first/top row of the backbox behind DP-DISP2. (Use ADP2-640 if mounting NFS2-640 chassis in a lower row.) NFS2-640 chassis holds four layers of equipment, including the control panel. See Figure 3.3. The primary display (KDM-R2 or NCA-2) mounts in front of NFS2-640/E.

The CPU mounts in the NFS2-640 chassis behind DP-DISP2 (top row) or ADP2-640 (lower row). The control panel fills three positions in the first-installed layer against the chassis; its power supply occupies two positions on top of the control panel; and the optional display occupies two positions in the fourth layer (flush with the dress panel).

Mount second, third, or fourth rows of equipment in other compatible chassis, such as chassis CHS-4L, CA-1, or CA-2. (See Table 3.3, “Chassis Compatibility,” on page 24.) For details on audio equipment see the *DVC Manual* and *DAA Manual*.

Option boards use standard mounting hole positions to allow them to be mounted in various locations and layers, depending on the desired system configuration. (See Table 3.2 to determine hardware.) Some equipment such as annunciators may be mounted on a dress panel directly in front of the control panel. The BMP-1 Blank Module Plate covers unused positions in a dress-panel, also providing an additional mounting location for some option boards, such as TM-4 (see *BMP-1 Product Installation Drawing* for details).

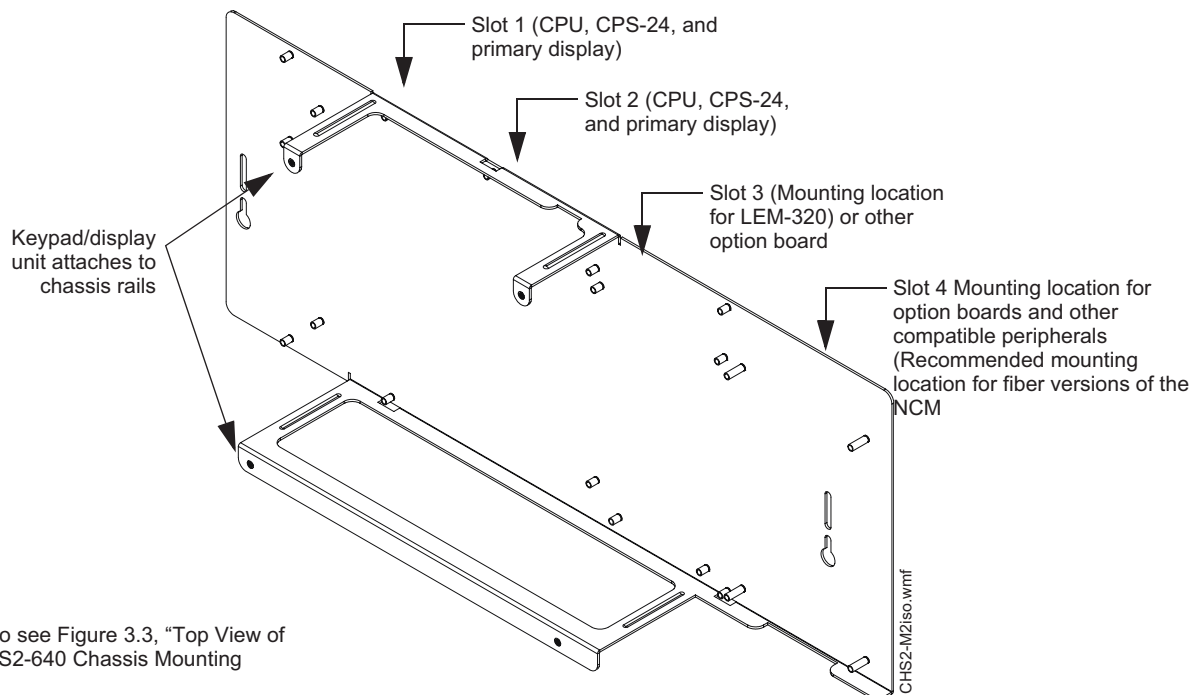
Annunciators can be mounted in dress panels such as ADP-4B; one or two annunciators can be installed in the DP-DISP2 or ADP2-640 with the control panel. Installing the BMP-1 blank plate in these dress panels provides an additional mounting location for option boards. Refer to the equipment's documentation for details.

Install BP2-4 Battery Plate in front of the battery compartment in NFS2-640/E installations and provides Protected Premises Unit labels.



**NOTE:** The BP2-4 is required for NFS2-640/E installations due to UL's revised labeling requirements. If using NFS2-640/E in retrofits, order BP2-4 to replace previous BP-4 battery dress panels.

If DP-DISP2 is not being used in the top row of the backbox, install VP-2B above the first row to cover the remaining space.

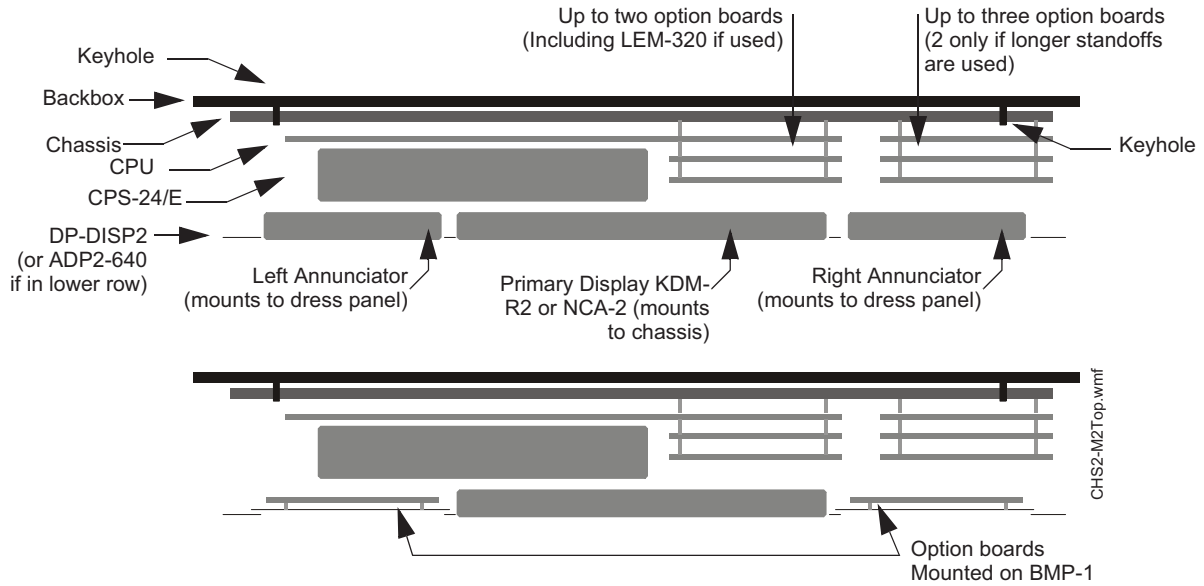


Also see Figure 3.3, "Top View of NFS2-640 Chassis Mounting"

**Figure 3.2 Side View of the NFS2-640 Chassis Mounting Options**



**NOTE:** When designing the cabinet layout, consider separation of power-limited and non-power-limited wiring as discussed in Section 3.11 "UL Power-limited Wiring Requirements".



**Figure 3.3 Top View of NFS2-640 Chassis Mounting Options**

From...	To...	Required Stand-off or Hardware
NFS2-640 chassis	Control panel or option board on first layer	Attaches directly to chassis.
NFS2-640 chassis	Keypad/display unit	Attaches directly to chassis rails.
NFS2-640 chassis	NCA-2	Attaches directly to chassis rails with mounting hardware NCA/640-2-KIT (ordered separately)
Control panel (third slot)	Any option board in third slot (such as LEM-320)	4 male-female stand-offs 1 inch (25.4 mm) P/N 42118; installed and shipped with CPU2-640/CPU2-640E.
Option board or NFS2-640 chassis (fourth slot)	Option board in next layer (not including LEM-320)	4 male-female stand-offs either 1.5 inch (38.1 mm) P/N 42175 or 0.937 inch (23.8 mm) P/N 42166, both shipped with option boards. Choose stand-off length that allows space for your option board's connectors; using longer stand-offs may reduce the number of option boards that fit in the chassis position.
Chassis or Dress Panel	Annunciator	Attaches directly to dress panels or attaches to flanges on chassis CHS-4/4N. (Screws provided with annunciator.)
Dress panels DP-DISP2, ADP2-640, ADP-4B	Option board	BMP-1 attaches to dress panel; option module attaches to BMP-1. (Screws provided with option module). See Figure 3.9.
Dress panel ADP-4B	NCA-2	Use "NCA-2 RETRO kit" hardware if mounting NCA-2 to a dress panel; cannot be mounted in front of the NFS2-640 chassis.

**Table 3.2 Stand-off Lengths**

Product	Chassis/Door-mounting options
NFS2-640/E	<ul style="list-style-type: none"> <li>NFS2-640 chassis</li> </ul>
NCA-2	<ul style="list-style-type: none"> <li>CHS-M2, NFS2-640 chassis, CHS-M3</li> <li>CA-2; requires two rows in the backbox</li> </ul>
DVC	<ul style="list-style-type: none"> <li>CA-1</li> <li>CA-2</li> </ul>
DAA	<ul style="list-style-type: none"> <li>Factory-mounted in its own chassis.</li> </ul>
Analog audio amplifiers AA-30, AA-100, AA-120	<ul style="list-style-type: none"> <li>Mounts directly onto CAB-4 backbox</li> </ul>
Option boards	<ul style="list-style-type: none"> <li>NFS2-640 chassis, CHS-4, CHS-4L, CHS-4N (shipped as part of kit CHS-4MB), or on BMP-1 inside dress plate</li> <li><b>Note:</b> Mount LEM-320 in front of CPU2-640 in the NFS2-640 chassis.</li> <li><b>Note:</b> Mount UDACT in second or lower row, or in slot 4 of the NFS2-640 chassis with nothing in front of it.</li> <li><b>Note:</b> Mount fiber versions of the NCM in the top row under knockouts, to avoid excessive bend on the fiber-optic cable.</li> </ul>
ACS series annunciators ACM-24AT, ACM-48A and expanders	<ul style="list-style-type: none"> <li>Dress Panel DP-DISP2, ADP2-640, or ADP-4B</li> </ul>

**Table 3.3 Chassis Compatibility**



**NOTE:** In retrofit applications, the CAB-3 series backbox may be used, but order BP2-4 to replace previous BP-4 battery dress panels.

Chassis/Dress plate	Typical Backbox Location(s) in CAB-4 Backboxes
NFS2-640 chassis	Top row of backbox typical; lower rows also possible.
CA-1	Second or lower row of backbox
CA-2	Requires two rows of backbox
CHS-4, CHS-4L, CHS-4N	Second or lower row of backbox
DPA-2 Dress Panel	Mounts in front of CA-2 covering two rows of the backbox
DP-DISP2 Dress Panel	Mounts in front of the NFS2-640 chassis in top row of backbox
ADP2-640 Dress Panel	Mounts in front of NFS2-640 chassis in second or lower row of backbox
ADP-4B Dress Panel	Mounts in front of any chassis

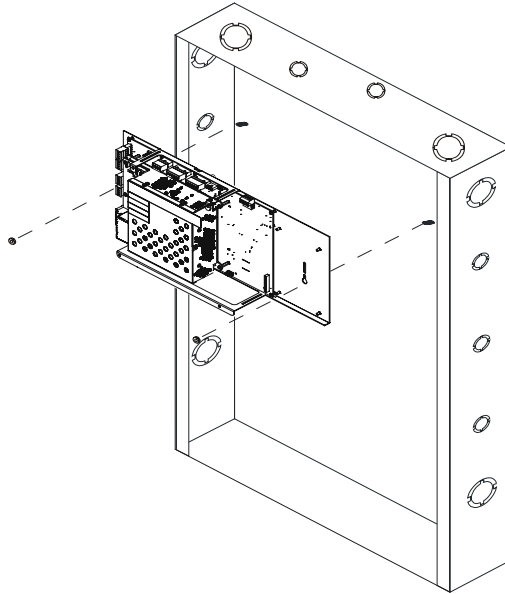
**Table 3.4 Chassis Locations in CAB-4 Backboxes**



## 3.5 Installing the Control Panel

### 3.5.1 Control Panel Circuit Board & Keypad/Display Unit

The control panel mounts in the NFS2-640 chassis, which is usually positioned in the top row of the backbox. The control panel's CPU occupies three positions at the back of the chassis; the KDM-R2 occupies three positions flush with the dress panel. The NCA-2 may be mounted directly in front of the control panel if no KDM-R2 is being used; use NCA/640-2-KIT as described in the *NCA-2 Installation Manual*.



**Figure 3.4 NFS2-640 Chassis Mounting**

Perform the following steps when installing the NFS2-640/E:

1. Screw chassis to the backbox.<sup>†</sup>
2. If installing KDM-R2 as primary display:
  - Attach ribbon cable from keypad to J7 connector on control panel. (See Figure 2.2.)
  - Align the keypad with the mounting holes as shown in Figure 3.8 and screw it down.
3. If installing the NCA-2 as primary display: Secure it to the NFS2-640 chassis with NCA/640-2-KIT as described in the *NCA-2 Manual*.
4. If installing option boards, do so as described in Section 3.6, “Mounting Option Boards”. If NFS2-640/E is being installed into an older backbox, two additional steps must be taken:
5. Battery Plate BP-4 must be replaced with BP2-4, per UL’s revised labeling requirements.
6. The older door and dress panel must be replaced with equipment compatible with KDM-R2.

<sup>†</sup>If the NFS2-640 chassis is not assembled as when shipped, attach CPU2-640 to the chassis. Slide control-panel tabs into slots on chassis and lay the board onto stand-offs so that mounting holes line up with those on the chassis. Secure with six screws and four 1 inch stand-offs as shown in Figure 3.5, “Mounting the CPU”.



**CAUTION:**

It is critical that all mounting holes of the NFS2-640/E are secured with a screw or standoff to insure continuity of Earth Ground.

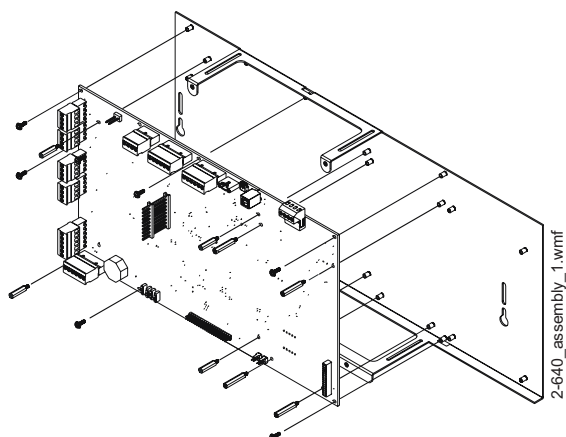


Figure 3.5 Mounting the CPU

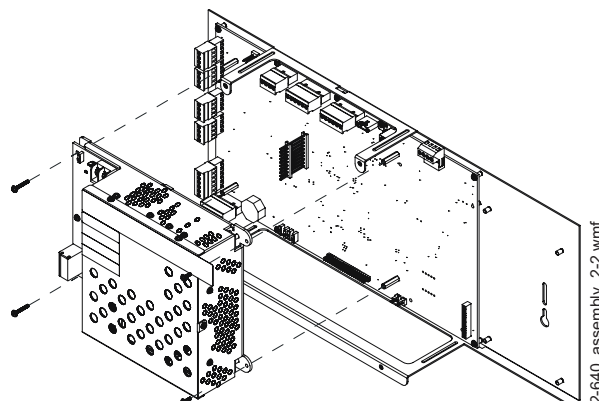


Figure 3.6 Mounting CPS-24/E

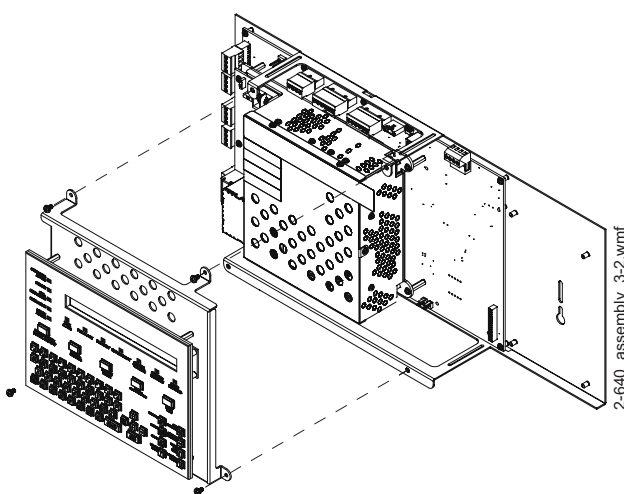


Figure 3.7 Mounting KDM-R2

### 3.5.2 Using NCA-2 as Primary Display

The NFS2-640/E can be set up to use the NCA-2 as the primary display. In this system design, mount NCA-2 to the NFS2-640 chassis in front of CPS-24/E, and connect the network/service port on the NFS2-640/E (J1) directly to the network/service port on the NCA-2 (J3). See the *NCA-2 Manual* for specific instructions.



**NOTE:** This system design is required in Canadian stand-alone applications.

If the NFS2-640/E and NCA-2 are being used as a stand-alone pair, each device must be programmed using VeriFire Tools. Connect the VeriFire Tools PC to NFS2-640 using USB B Port J3 and program as described in VeriFire Tools on-line help.

For older PCs without USB connectors, NFS2-640/E and NCA-2 must be temporarily disconnected and separately programmed, because VeriFire Tools also uses the network/service port. Follow VeriFire Tools instructions for off-line programming mode.

If the NFS2-640/E with NCA-2 is connected to a network, there are two additional options for programming: either connect the VeriFire Tools programming PC to the network port on the NCM board, or program the NFS2-640/E through another network node.



**NOTE:** This is the only NCA-2 application that does not require an NCM connection to NotiFireNet.

## 3.6 Mounting Option Boards

If installing option boards into a CAB-4 Series backbox, mount and connect those boards at this time. General instructions follow; the sections about individual option boards contain any module-specific instructions such as mounting LEM-320's stacker-connector.

### 3.6.1 Option Boards in the NFS2-640 Chassis

Mount option boards in slots 3 and 4 of the NFS2-640 chassis. (See Figure 3.2, Figure 3.8, and Figure 3.9.) For standoff lengths, see Table 3.2.



**NOTE:** Another option board can be mounted above a Loop Expander Module or Network Communications Module; for ease of access, be sure to complete installation of those devices before mounting a second layer.



**NOTE:** If using the fourth (right-side) position of the NFS2-640 chassis, the chassis needs to be installed on the backbox before option boards or modules are installed in that position. These modules will block access to the keyhole opening.

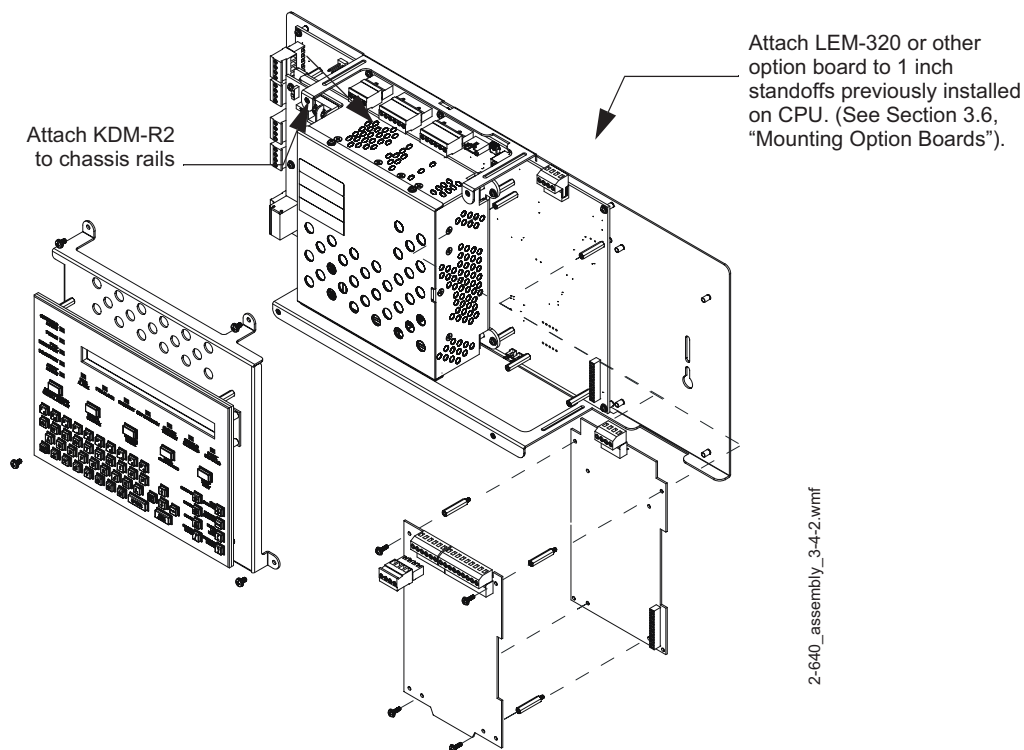
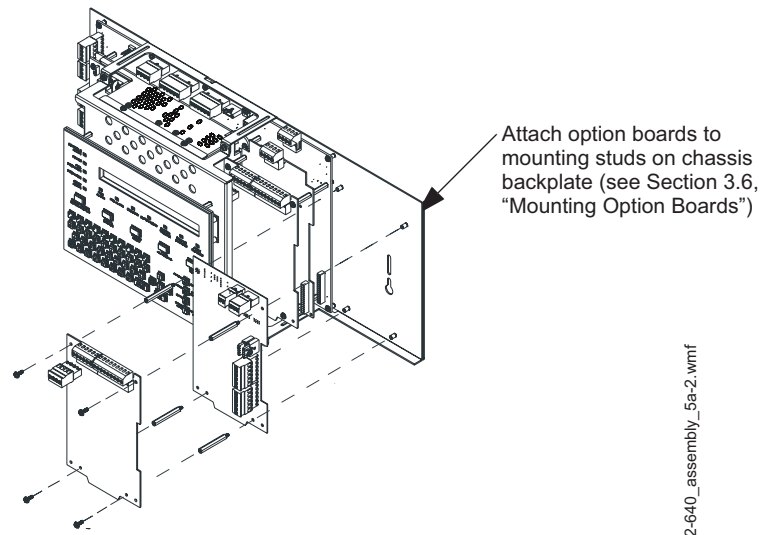


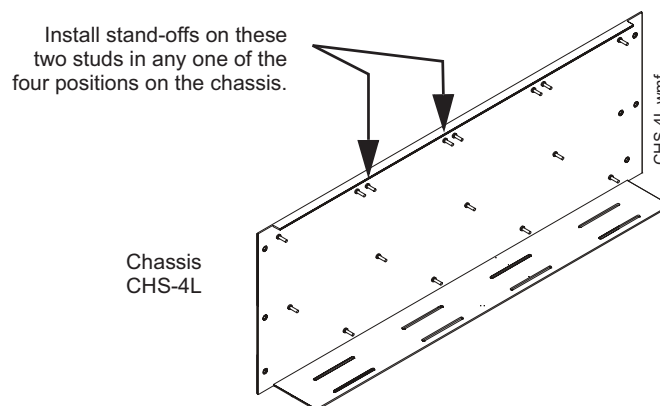
Figure 3.8 Attaching Option Boards Behind KDM-R2



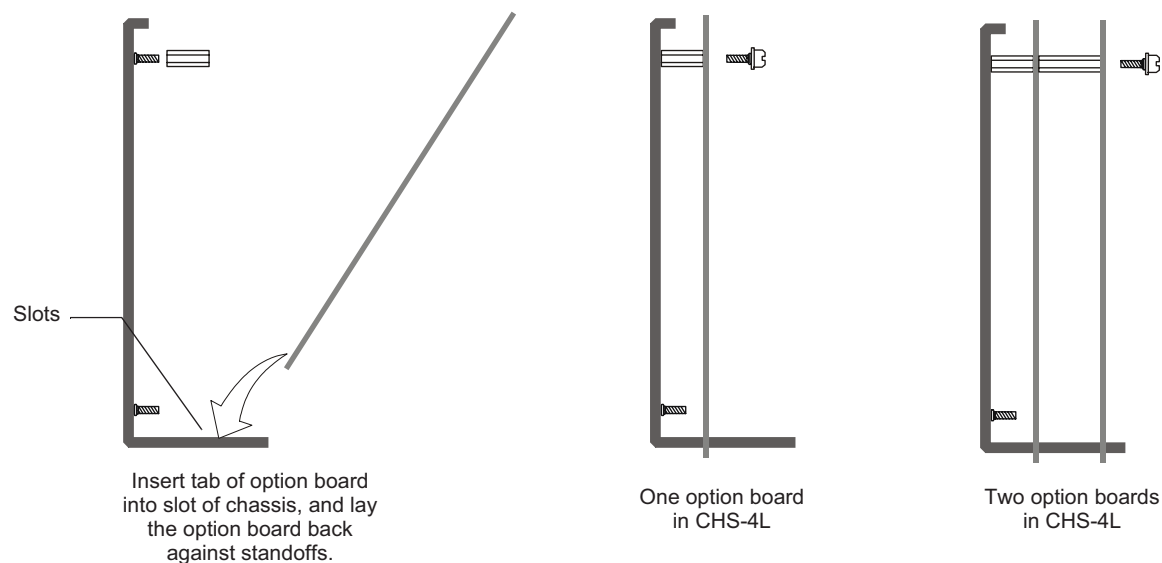
**Figure 3.9 Attaching Option Boards to the Right of the CPU**

### 3.6.2 Option Boards in CHS-4L

1. Slide the tabs at the bottom of the option board into slots on the chassis as shown in Figure 3.11.
2. Lay the board back onto the flanges so that the studs line up with mounting holes on the option board.
3. Attach the option board using screws provided with the board, or if installing a second option board, with stand-offs provided with the second board.



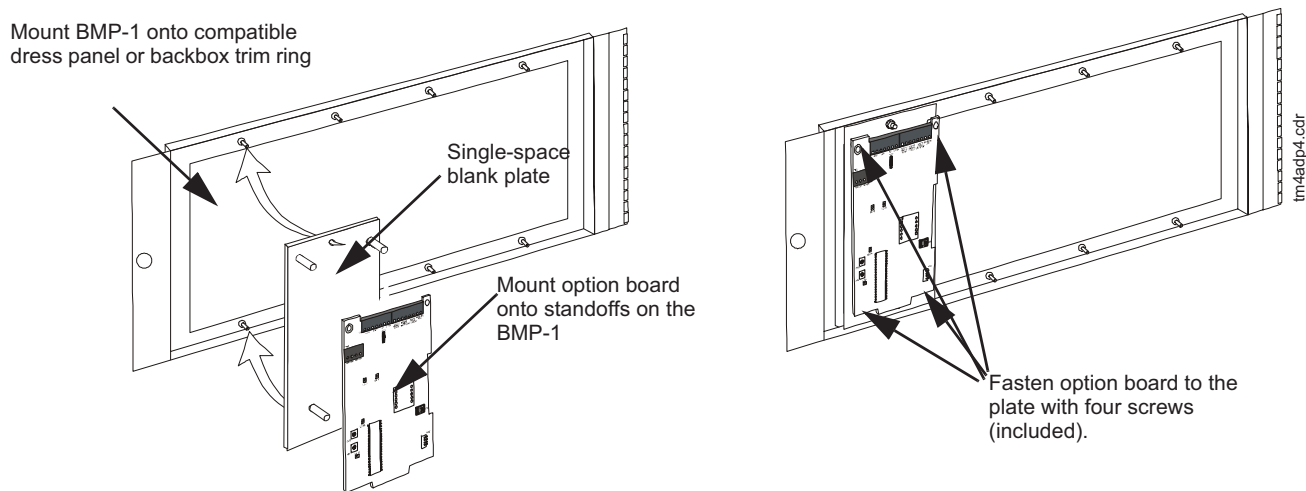
**Figure 3.10 Standoff Locations on CHS-4L**



**Figure 3.11 Mounting an Option Board in a Chassis (CHS-4L Shown)**

### 3.6.3 Option Boards on BMP-1 in Dress Panels

Option boards can be mounted on BMP-1 blank module plate, inside dress panels such as DP-DISP2, ADP2-640, ADP-4B, as shown in Figure 3.12.



**Figure 3.12 Mounting an Option Board onto a Dress Panel with BMP-1 (ADP-4B Shown)**



**NOTE:** See the *BMP-1 Product Installation Drawing* for details if considering mounting the module behind blank module plate in a dress plate or annunciator backbox. This dress plate is suitable for modules that do not need to be visible or accessible when the door is closed.

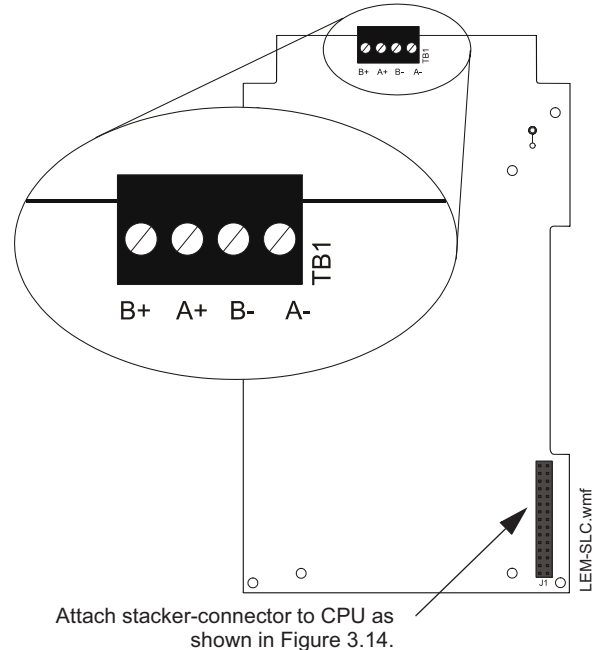
### 3.6.4 Transmitter Module TM-4

TM-4 is power-limited. Connections are on TB10 nonresettable output and TB11 EIA-485 ACS Mode. Refer to the *Transmitter Module TM-4* installation document for installation details.

### 3.6.5 Loop Expander Module

Installing a Loop Expander Module adds a second SLC loop to the control panel. Refer to Figure 3.14 for stacker-connector illustrations.

1. Plug short end of the stacker-connector into J4 on the CPU2-640.
2. Align the LEM with the four 1 inch standoffs and the stacker-connector as shown in Figure 3.14; firmly seat the stacker-connector.
3. Attach LEM to standoffs using screws or another set of standoffs, using proper LEM screw/standoff locations. Refer to Figure 3.12 on page 29.
4. After LEM is mounted on the control panel, connect the SLC loops to TB1 on the LEM and TB13 on the CPU2-640. This system supports either FlashScan or CLIP mode devices. Refer to the SLC loop manual for wiring requirements and specific details.



**Figure 3.13 SLC Connections for LEM-320**



**CAUTION:**

For the SLC to function correctly, the stacker-connector must be installed as shown in Figure 3.14. **Do not install any option module on top of the LEM-320.**



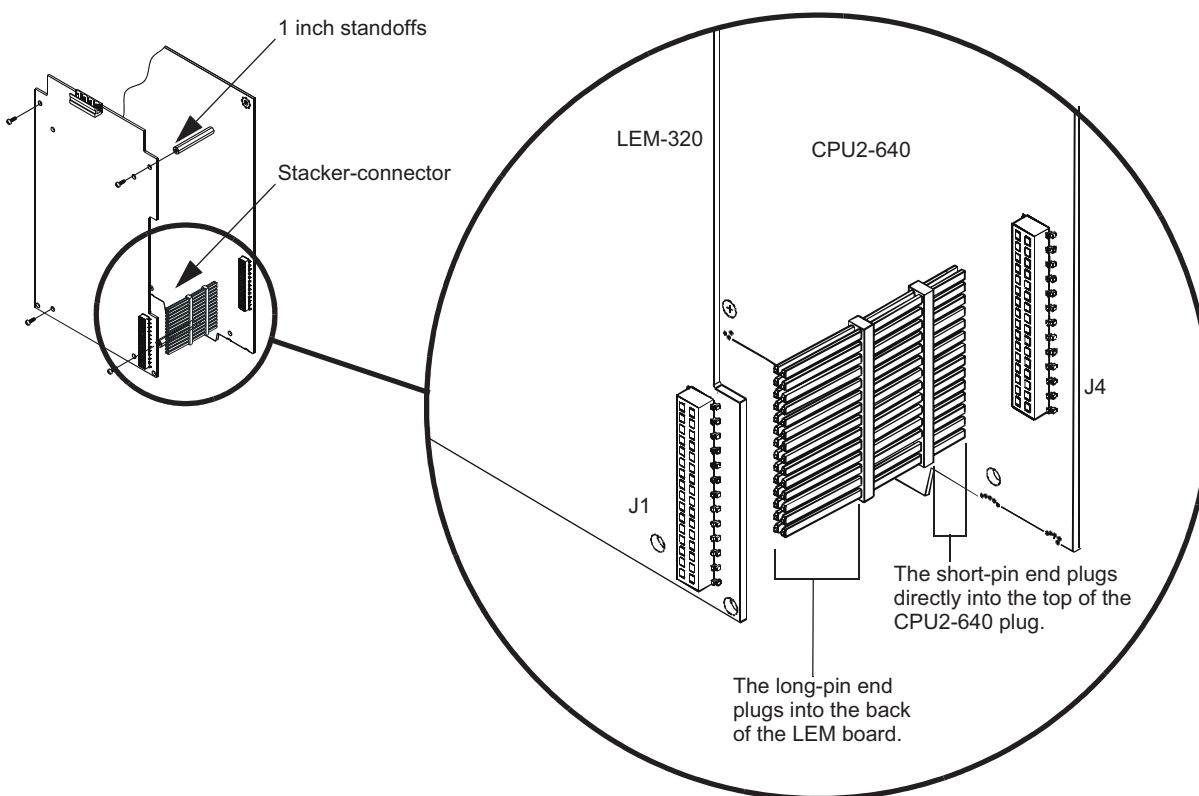


Figure 3.14 Mounting LEM-320 with the Stacker-connector

2-640\_assembly\_6a.wmf

### 3.6.6 Network Communications Module

If networking two or more control panels or network control annunciators, each unit requires a Network Communications Module (NCM); wire and fiber versions of each are available. The wire and/or fiber versions of the NCM can be installed in any standard option-board position (see Section 3.6 “Mounting Option Boards”); the default position is immediately to the right of the control panel.

1. Mount the NCM in the selected position and screw in place firmly.
2. Connect J1 on the control panel to J3 on the NCM using the network cable provided (P/N 75556) as described in the *NCM Installation Document*. Do not connect two NCMs via NUP ports (aka NUP to NUP).
3. **When installing the NCM:** Connect Channel A and/or Channel B as described in the *NCM Installation Document*.



**NOTE:** See the *Noti•Fire•Net Manual* and *NCM Installation Document* for wiring diagrams and system configuration information. See the *BMP-1 Product Installation Drawing* if considering mounting the module behind blank module plate in a dress plate or annunciator backbox.



**NOTE:** Over-bending fiber-optic cable can damage it. Do not exceed a 3 inch (7.62 cm) minimum bend radius.

### 3.6.7 DVC Digital Voice Command

Each DVC Series model is a multi-featured audio processor with digital audio functionality that operates as an event-driven audio message generator and router. It is designed for use with the DAA Series digital audio amplifiers in a single panel or networked environment, and may also be used as an analog audio source.

The NFS2-640/E may be directly connected to the DVC for single panel applications. An associated NCA-2 is required when a DAL (digital audio loop) is part of the configuration.

Network configurations require an associated NCA-2, and will support all Network Control-by-Event.



---

**NOTE:** The DVC Series consists of all the model versions listed in the bullets below this note. Individual part numbers are used in this manual only when it is necessary to distinguish features or functions that differ. The term DVC is used in all other cases.

---

- DVC-EM - Digital Voice Command, extended memory, wire version (standard)
- DVC-EMF - Digital Voice Command, extended memory, multi-mode fiber version
- DVC-EMSF - Digital Voice Command, extended memory, single-mode fiber version.

For information regarding audio storage for the DVC-EM Series models listed above, refer to the *DVC and DAA Digital Audio Series Manual*.



---

**NOTE:** The term DAA is used in this manual to refer to all DAA wire and fiber models. Individual part numbers are used only when it is necessary to distinguish features or functions that differ.

---

Figure 3.15 gives simplified overview illustrations of typical applications for the DVC Series and its Digital Audio Loop (DAL).



---

**NOTE:** A DAL must be connected with one of the following bulleted options below:

---

- All wire connections
- All single-mode fiber connections, or
- All multi-mode fiber connections.

Wire and fiber, or multi-mode and single-mode, can not be mixed.

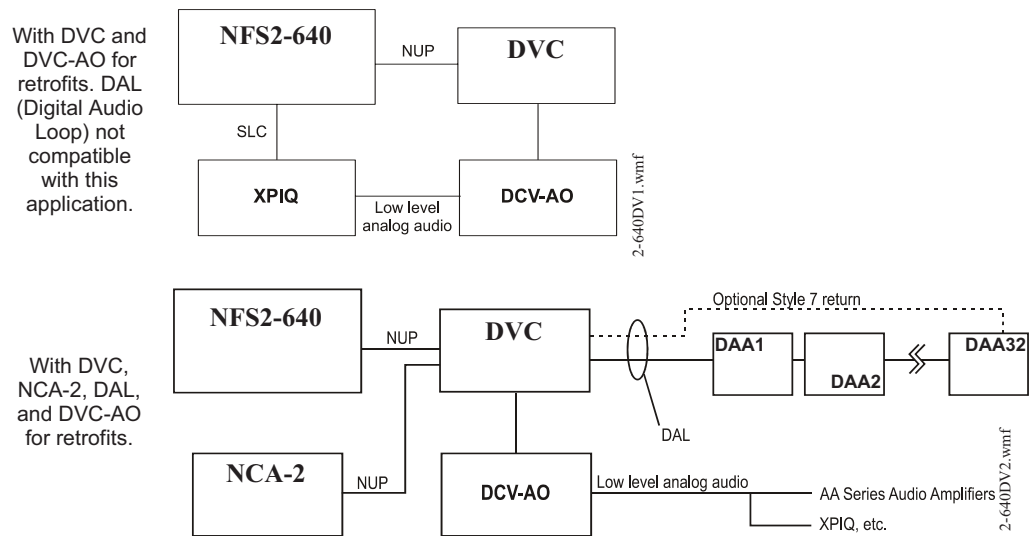


Figure 3.15 Block Diagrams of DVC Series Applications

## 3.7 Connecting the Power Cables



**WARNING:**

Remove all power sources to equipment while connecting electrical components. Leave the external, main power breaker OFF until installation of the entire system is complete.



**WARNING:**

Several sources of power can be connected to the control panel. Before servicing the control panel, disconnect all sources of input power *including the battery*. While energized, the control panel and associated equipment can be damaged by removing and/or inserting cards, modules, or interconnecting cables.

### 3.7.1 Overview

Complete all mounting procedures and check all wiring before applying power. Electrical connections include the following:

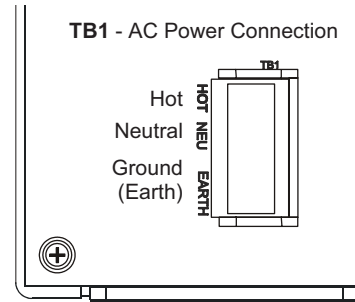
- Primary AC power source – 120 VAC, 50/60 Hz, 5.0 A (with NFS2-640E use 240 VAC, 50/60 Hz, 2.5 A) from line voltage source. Overcurrent protection for this circuit must comply with Article 760 of the National Electrical Code (NEC) and/or local codes. Use 12 AWG (3.31 mm<sup>2</sup>) wire (maximum) with a 600-volt rating.
- Secondary power source – 24 VDC from batteries, installed in the control panel (or in an optional battery cabinet). Secondary (battery) power is required to support the system during loss of primary power.
- External power sources – 24 VDC power for Smoke Detectors (4 wire), NACs, and Annunciators.
- Auxiliary power source – 24 VDC power @ 0.5 A and 5 VDC power @ 0.15 A from TB2 on the CPS-24/E.

See Appendix B “Electrical Specifications” for details and overall installation guidelines.

### 3.7.2 Connecting the Control Panel to AC Power

Connect primary power as follows (see Figure 3.16):

1. Turn off the circuit breaker at the main power distribution panel.
2. Open the hinged insulating cover on TB1.
3. Connect the service ground to terminal marked Ground (Earth).
4. Connect the primary neutral line to terminal marked NEUTRAL and the primary Hot line to terminal marked HOT.
5. Close the hinged insulating cover over TB1.



**Figure 3.16 CPS-24/E:  
AC Power Connections**

### 3.7.3 Checking AC Power

Table 3.5 contains a checklist for checking the system with AC power applied:



**CAUTION:**

While checking AC power, make sure batteries are not connected. Follow the sequence of steps in Section 3.2 “Installation Checklist”, Table 3.1; this is Step 15.

Component	Status
Control panel circuit board	The green AC Power indicator on; the system Trouble indicator on because batteries are not connected.
Each option board	The yellow Trouble indicator may come on for approximately 10 seconds after applying AC power. (This only applies to an unconfigured system.)
Each auxiliary power supply	The yellow Trouble indicator comes on because batteries are not connected.

**Table 3.5 AC Power Checklist**

### 3.7.4 Installing and Connecting the Batteries



**WARNING:**

Battery contains sulfuric acid which can cause severe burns to the skin and eyes, and can destroy fabrics. If contact is made with sulfuric acid, immediately flush skin or eyes with water for 15 minutes and seek immediate medical attention.



**WARNING:**

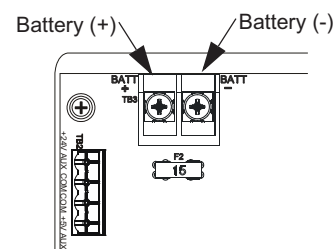
Do not connect the Battery Interconnect Cables (P/N 75560 and 75561) at this time. Make this connection AFTER initial system primary powerup. Follow sequence of steps in Section 3.2 “Installation Checklist”, Table 3.1; this is Step 16.

Batteries are installed in the control panel cabinet or in a separate battery cabinet which can be mounted below the control panel or up to 20 feet (6.096 m) away from the control panel, in conduit in the same room.

Connect the battery as follows (see Figure 3.16 above):

1. Install batteries into bottom of cabinet or into separate battery cabinet.
2. Connect the red cable from TB3(+) on the CPS-24/E power supply to the positive (+) terminal of one battery.
3. Connect the black cable from TB3(–) on the CPS-24/E power supply to the negative (–) terminal of the **other** battery.
4. Connect the remaining cable between the negative (–) terminal on the first battery to the positive (+) terminal on the second battery.

**TB3 - Battery Connection**



**Figure 3.17 CPS-24/E: DC Power Connections**

### 3.7.5 External DC Power Output Connections

Terminal TB10 provides two (2) power outputs, resettable and non-resettable. Each output is power-limited. Follow sequence of steps in Section 3.2 “Installation Checklist”, Table 3.1; this is part of Step 6. TB10 and all 4 NACs share a maximum of 3.0 A.

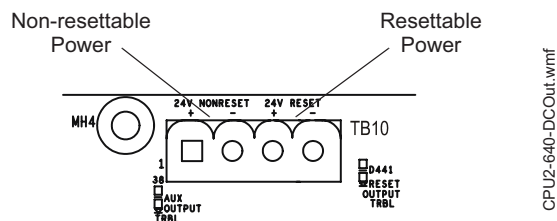


Figure 3.18 Power Supply DC Outputs - TB10

**24 VDC Resettable Power Circuit (Four-Wire Smoke Detectors).** The power supply provides a single 24 VDC filtered, power-limited, resettable power circuit for devices that require resettable power (such as four-wire smoke detectors). This circuit is power-limited, but must be supervised. To provide supervision, install a UL-listed end-of-line power supervision relay (such as the System Sensor model EOLR-1) after the last device. Connect the power supervision relay normally open contact in series with an Initiating Device Circuit (IDC). The four-wire power circuit energizes the power supervision relay. When you reset the system, the control panel removes power from these terminals for approximately 15 seconds.

Connect external field wires to the power supply terminals TB10 RESET(+) and (–) to provide up to 1.25 A of current for powering four-wire smoke detectors. See Figure 3.18 above. TB10 and all 4 NACs share a maximum of 3.0 A.

**24 VDC Non-resettable Power Circuit** The power supply provides one 24 VDC filtered, power-limited, non-resettable power output, capable of up to 1.25 A. Use this circuit to power devices that require low-noise 24 VDC power (such as Notifier annunciator model ACM-24AT or the transmitter module TM-4).

Connect external field wires to power supply terminals TB10 NONRESET(+)and(–) to provide up to 1.25 A of non-resettable current for powering external devices such as annunciators. See Figure 3.18 above. TB10 and all 4 NACs share a maximum of 3.0 A.



**CAUTION:**

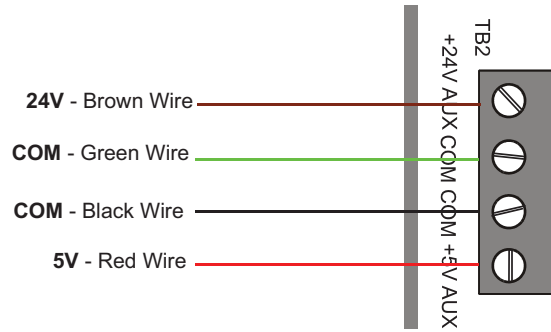
During system reset, power remains at terminals TB10 NONRESET(+)and(–).

### 3.7.6 Accessories DC Power Output Connections

Terminal TB2 supplies one (1) non-resettable, power-limited 24 VDC circuit and one non-resettable, power-limited 5 VDC circuit available to power external devices. Applications that require a 5V connection to the Accessories Output, such as an UZC-256, must be within 10 feet (3.658 meters) of the power supply and should use the supplied cable, P/N 75657. Do not splice or otherwise extend P/N 75595. Refer to section B.2, "Wire Requirements" of this manual for all applications requiring a 24V connection. Connect wiring with all power sources off.

- 24 VDC (nominal) @ 0.5 A max
- 5 VDC (nominal) @ 0.15 A max





AMPS24\_TB2access.wmf

Figure 3.19 Connecting to the Accessories Output TB2 on CPS-24/E

### 3.8 NAC Connections and Releasing Circuits

The control panel provides four NAC terminals as shown in Figure 3.21. Each can be configured as Style Y (Class B) or Style Z (Class A) as shown in Figure 3.20. Each circuit can provide 1.5 A of current, but the total current drawn from the main power supply cannot exceed 7.4 A in alarm condition (refer to Table A.2). Additionally, TB10, TB2, and all 4 NACs share a maximum of 3.0 A in standby; see Appendix A. NAC circuits are supervised and power-limited. Use UL-listed 24 VDC notification appliances only (refer to the *Device Compatibility Document*).

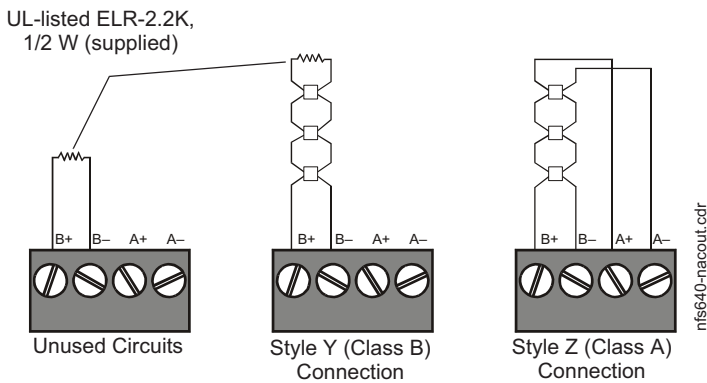


Figure 3.20 Notification Appliance Circuit (NAC) Connections

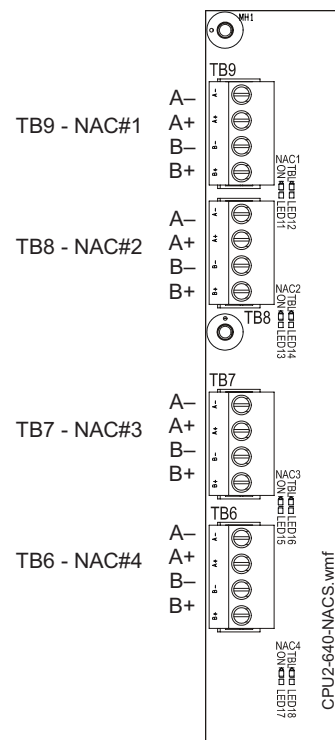


Figure 3.21 NAC Terminals and NAC LEDs



**NOTE:** Any NAC can be programmed as a releasing circuit, and the releasing circuit must be supervised; see Figure 4.7–Figure 4.9. For more information, refer to Section 4.6 “Releasing Applications” in this manual and the *NFS2-640/E Programming Manual*. Refer to the *Device Compatibility Document* for UL-listed compatible releasing devices. Sample connections for NAC terminals are shown in Figure 3.20. Follow sequence of steps in Section 3.2 “Installation Checklist”, Table 3.1; this is part of Step 6.

### 3.9 Output Relay Connections

The panel provides a set of Form-C relays. These are rated for 2.0 A at 30 VDC (resistive):

- Alarm - TB4
- Trouble - TB4
- Supervisory - TB5
- Security - TB5

These are power-limited only if connected to a power-limited source.

Using VeriFire Tools, the Supervisory and Security contacts can also be configured as Alarm contacts. Follow instructions in the VeriFire Tools online help.

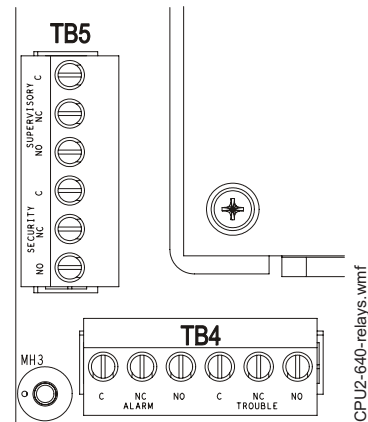


Figure 3.22 Form-C Relay Connections

### 3.10 Backup-Alarm Switches



**WARNING:**

Do not enable the BACKUP option switch for any of the four Notification Appliance Circuits (NACs) if they are used for releasing functions!

Backup alarm switches are provided that enable NACs and the alarm relay to activate during a backup alarm condition. If the main board’s microcontroller fails and an alarm is reported by any detector or a monitor module that has backup reporting enabled, the NAC will turn on if the corresponding switch was enabled. The alarm will activate during microcontroller failure regardless of the settings of switches SW1–SW4.

- SW1 - NAC#1
- SW2 - NAC#2
- SW3 - NAC#3
- SW4 - NAC#4

So, for example, if SW1 and SW4 were enabled at the time of an alarm during microcontroller failure, NAC#1 and NAC#4 would activate. Follow sequence of steps in Section 3.2 “Installation Checklist”, Table 3.1; this is Step 7.

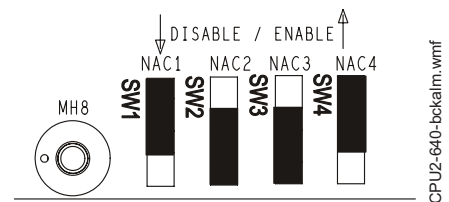
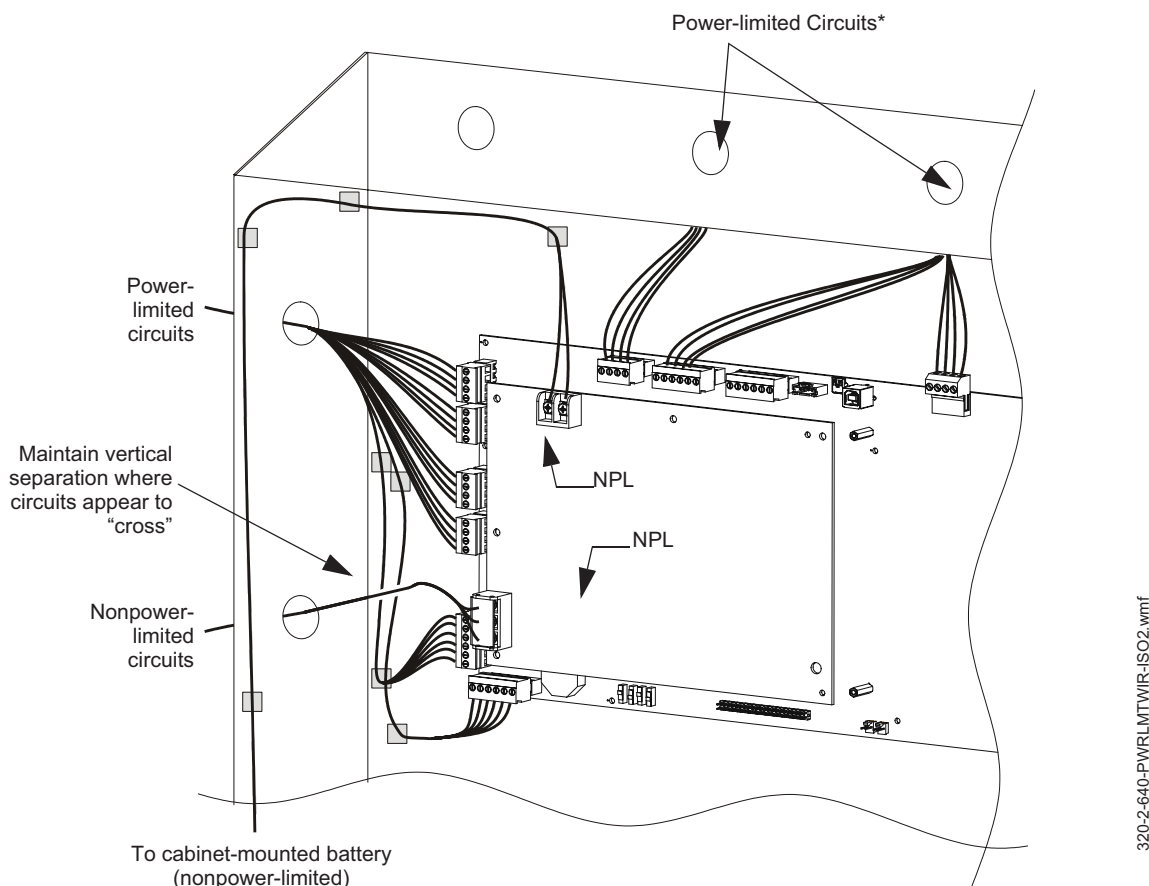


Figure 3.23 Backup Alarm Switches

## 3.11 UL Power-limited Wiring Requirements

Power-limited and nonpower-limited circuit wiring must remain separated in the cabinet. All power-limited circuit wiring must remain at least 0.25 inches (6.35 mm) from any nonpower-limited circuit wiring. All power-limited and nonpower-limited circuit wiring must enter and exit the cabinet through different knockout and or conduits. To maintain separation, group non-power limited modules together, i.e., group modules on the same side of the enclosure or in separate rows.

Figure 3.24 shows one configuration that meets these UL requirements. The first two rows of modules are configured with at least a 0.25 inch (6.35 mm) separation between power-limited and nonpower-limited wiring; AC and battery wiring is routed away from power-limited wiring.



**Figure 3.24 Typical Wiring for UL Power-limited Wiring Requirements  
(Shown with relays as connected to power-limited modules)**



**NOTE:** AC and battery wiring are not power-limited. Maintain at least 0.25 inches (6.35 mm) between power-limited and non power-limited circuit wiring. Install tie wraps and adhesive squares to secure the wiring. Use a power-limited source for relay output on terminals TB8 – TB11. See Figure 2.2, “CPU2-640/CPU2-640E and Power-Supply: Wiring Connections” on page 14 to identify power-limited and non-powerlimited circuits.

**NOTE:** Drawing is not to scale; proportions and angles are exaggerated to show wire-placement more clearly.

### 3.11.1 Labeling Modules and Circuits

At the time of installation, each nonpower-limited circuit connected to ACM-8R, and LDM-R32 modules must be identified in the space provided on the cabinet door label when connected to a non-power-limited source of power.

The label lists all compatible power-limited modules and circuits; also see Figure 2.2 on page 14.

The LDM-R32 is power-limited only when connected to power-limited sources. When connected to a non-power-limited source, the power-limited marking must be removed.

## 3.12 Installing EIA-485 Devices

Figure 3.25 provides a closer view of the EIA-485 connections provided on TB11. Because specific connections can vary by the type of device being connected, refer to the product installation manual for details.

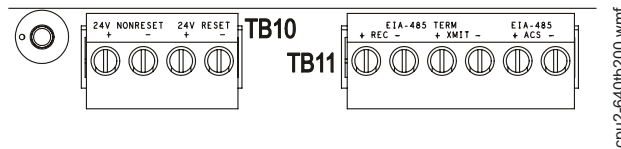


Figure 3.25 EIA-485 Connections

## 3.13 Installing Remote Printers and/or CRT

### 3.13.1 Custom Cable Fabrication

A custom cable needs to be fabricated to connect the PRN Printer, Keltron Printer or the CRT-2 Monitor to the system. Length of the cable will vary with each installation, but should not exceed a maximum length of 20 feet (6.1 m). Printer must be installed in the same room as the panel, and the cable be installed in conduit. Construct cable as follows:

1. Using overall foil/braided-shield twisted-pair cable, properly connect one end to the DB-25 Connector using the wiring specifications shown in the table below. (Custom cable kit P/N 90106 is provided.)
2. Tighten clamp on connector to secure cable.

DB-25 Connector (Custom cable kit 90106)	TB12 on Control Panel
Pin 3	TX
Pin 2	RX
Pin 7	REF

### 3.13.2 Installing and Configuring the PRN Series Printer

When connected to the Control Panel via an EIA-232 interface, the PRN prints a copy of all status changes within the control panel and time-stamps the printout with the time of day and date the event occurred. It provides 80 columns of data on standard 9" by 11" tractor-feed paper.



**NOTE:** You can also use the EIA-232 printer interface with UL-listed information technology equipment, such as personal computers, to monitor the control panel for supplementary purposes.

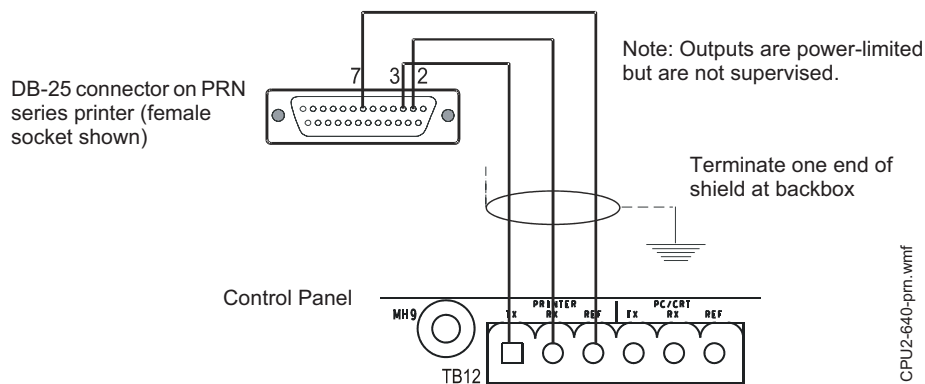
This section contains information on connecting a printer to the control panel and for setting the printer options.

#### Connecting a Remote PRN Series Printer

Remote printers require a 120 VAC, 50/60 Hz primary power source. If required for the fire alarm system configuration (for example, a Proprietary Fire Alarm System), a remote printer requires a secondary power source (battery backup). Because a secondary power source is not provided, use a separate Uninterruptable Power Supply (UPS) that is UL-listed for Fire Protective Signaling. You may use your building emergency power supply, so long as it meets the power continuity requirements of NFPA 72. Refer to NFPA 72 for further details.

Connect the remote printer to the Control Panel as follows:

1. Connect the three (3) open leads of the custom cable to the TB12 terminal block on the control panel as shown in Figure 3.26.
2. Plug the DB-25 connector end of the custom cable into the EIA-232 port of the remote printer. Tighten securely.



**Figure 3.26 Remote Printer Connections**

#### Setting Printer Options

Refer to the documentation supplied with the PRN series printer for instructions on using the printer menu controls. Set the printer options (under the menu area) according to the settings listed in Table 3.6.

Option	Setting	Option	Setting
Font	HS Draft	CPI	10 CPI
LPI	6 LPI	Skip	0.5
ESC Character	ESC	Emulate	Epson FX-850
Bidirectional Copy	ON	I/O	
CG-TAB	Graphic	Buffer	40K
Country	E-US ASCII	Serial	
Auto CR	OFF	Baud	9600, 4800, or 2400
Color Option	Not Installed	Format	7 Bit, Even, 1 Stop
Formlen		Protocol	XON/XOFF
Lines	6LPI=60	Character Set	Standard
Standard	Exec 10.5	Sl.Zero	On
		Auto LF	Off
		PAPER	
		BIN 1	12/72"
		BIN 2	12/72"
		SINGLE	12/72"
		PUSH TRA	12/72"
		PULL TRA	12/72"
		PAP ROLL	12/72"

Table 3.6 PRN Setup Options

### 3.13.3 Installing and Configuring a Keltron Printer

Connect the remote printer to the Control Panel as follows:

1. Connect the three (3) open leads of the custom cable to the TB12 terminal block on the control panel as shown in Figure 3.27.
2. Connect DC power from TB10 terminal block on the control panel as shown in Figure 3.27.
3. Plug the DB-25 connector end of the custom cable into the EIA-232 port of the Keltron printer. Tighten securely.

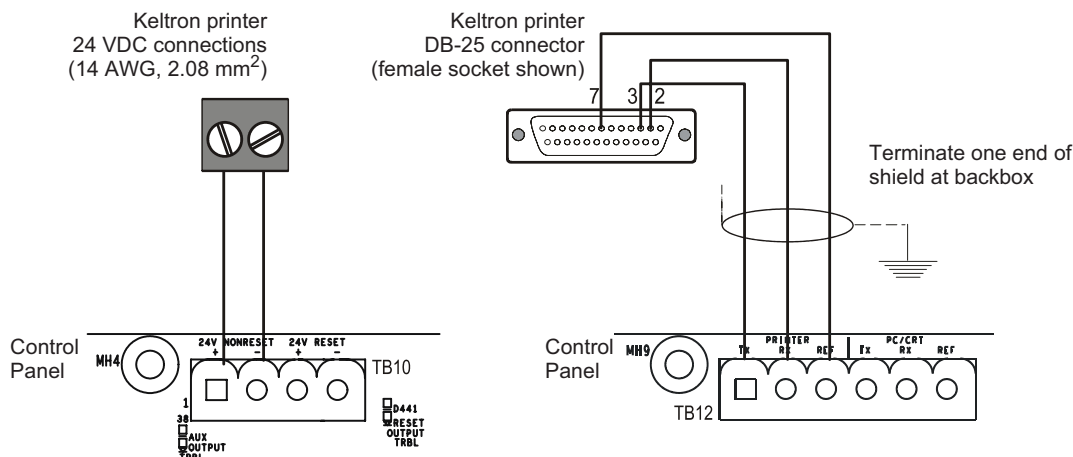


Figure 3.27 Keltron Printer Connections

#### Setting up the Keltron Printer

Set up a Keltron printer as follows:

1. The printer communicates using the following protocol:
  - Baud Rate: 9600
  - Parity: Even
  - Data bits: 7
2. Set the printer DIP switches SP1 and SP2 according to settings in Table 3.7.

CPU2-640-keltron.wmf



SP1	On	Off
1		X
2		X
3		X
4	X	
5		X
6	X	
7	X	
8		X

SP2	On	Off
1		X
2		X
3		X
4	X	
5		X
6		X
7	X	
8		X

Table 3.7 Keltron DIP Switch Settings

### 3.13.4 Installing and Configuring a CRT-2

A CRT-2 can only be used in a non-networked application when used with the NFS2-640/E. For further details on setting up the CRT-2, refer to the *NFS2-640/E Operations Manual*.

Connect a CRT-2 to the Control Panel as follows:

1. Connect the three (3) open leads of the custom cable to the TB12 terminal block on the control panel as shown in Figure 3.28.
2. Plug the DB-25 connector end of the custom cable into the EIA-232 port of the CRT-2. Tighten securely.
3. Set parameters as discussed in Table 3.28.

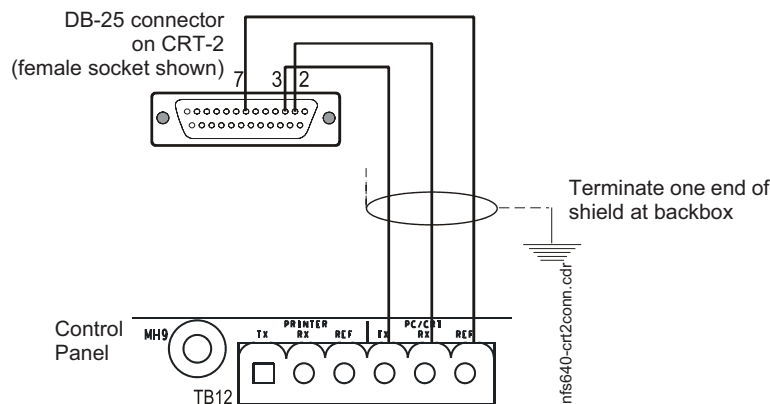


Figure 3.28 Connecting a CRT-2

#### Setting CRT-2 Parameters

The CRT-2 communicates with the control panel through a protocol defined by thirteen groups of parameters. To access a parameter group, press the corresponding function key (F1-F12) as shown in Table 3.8 below. You can then program parameters in each group.

Enter the CRT-2 setup menu by pressing and holding the <Ctrl> key while pressing the <Scroll Lock> key. Use arrow keys to move through the selections in each setup group; press the space bar to view the options for each parameter. When finished programming all setup groups, press the <Pause> key. To save all changes, press <Y>.

Table 3.8 shows the standard settings for using the CRT-2 with the NFS2-640/E; for one instance where these settings may change slightly see Section 3.13.5 “Connecting Multiple Printers, CRTs, or CRT/PRN Combination”. The basic settings for using the CRT-2 with NFS2-640/E are:

- Baud Rate 9600
- Data format 8 1 N
- Protocol xon/off.



**NOTE:** This section covers installation only; for information on how the CRT-2 functions as part of the fire alarm system, see the *NFS2-640/E Operations Manual*.



**NOTE:** The CRT cannot be connected at the same time as the network.

Function Key	CRT-2 Parameters		
F1: Quick (“Read Status” key)	Emulation=CRT-2 Comm Mode=Full Duplex Enhanced=On	EIA Baud Rate=9600 Aux Baud Rate=9600 Language=U.S.	EIA Data Format=8/1/N Aux Data Format=8/1/N Host/Printer=EIA/Aux
F2: Genrl (“Alter Status” key)	Emulation=CRT-2 Auto Font Load=On Monitor Mode=Off Host/Printer=EIA/Aux	Enhanced=On Auto Page=Off Bell Volume=09	Auto Wrap=Off Auto Scroll=On Warning Bell=On
F3: Displ (“Prog” key)	Page Length=24 Display Cursor=On Columns=80 Scroll=Jump	Screen Length=26 Lines Cursor=Blink Line Width Change Clear=Off Refresh Rate=60 Hz	Screen Video=Normal Auto Adjust Cursor=On Speed=Normal Overscan Borders=Off
F4: Kybd (“Spl Funct” key)	Language=U.S. Keyclick=Off Key Lock=Caps	Char Set Mode=ASCII Key Repeat=Off Keyboard Present=Yes	Key Mode=ASCII Margin Bell=Off
F5: Keys (“Prior” key)	Enter Key=<CR> Alt Key=Meta Pound Key=U.S.	Return Key=<CR> Disconnect=Pause	Backspace=<BS>/<DEL> Desk Acc=Disabled
F6: Ports (“Next” key)	EIA Baud Rate=9600 Aux Baud Rate=9600 EIA Xmt=Xon-Xoff Aux Xmt=Xon-Xoff EIA Break=Off Aux Break=Off	EIA Data Format=8/1/N Aux Data Format=8/1/N EIA Recv=Xon-Xoff(XPC) Aux Recv=Xon-Xoff(XPC) EIA Modem Control=Off Aux Modem Control=Off	EIA Parity Check=On Aux Parity Check=On EIA Xmt Pace=Baud Aux Xmt Pace=Baud EIA Disconnect=2 sec Aux Disconnect=2 sec
F7: Host (“Auto Step” key)	Comm Mode=Full Duplex Recv <DEL>=Ignore Send Block Term=<CR>	Local=Off Send ACK=On Null Suppress=On	Recv <CR>=<CR> Send Line Term=<CR><LF>
F8: Print (“Activ Signal” key)	Prnt Line Term=<CR><LF>	Prnt Block Term=<CR>	Secondary Recv=Off
F9: Emul	Attribute=Page WPRT Intensity=Dim WPRT Blink=Off Status Line=Off	Bright Video=Off WPRT Reverse=Off Display NV Labels=Off Fkey Speed=Normal	Page Edit=Off WPRT Underline=Off Save Labels=On
F10	Setup Group F10 does not affect communications with the control panel.		
F11	Setup Group F11 does not affect communications with the control panel.		
F12: Prog (“Ack Step” key)	Program the function keys as follows: F1 ~A F2 ~B F3 ~C F4 ~D F5 ~E F6 ~F F7 ~G F8 ~H F9 ~I F10 ~J F11 ~K F12 ~L F13 ~M F14 ~N F15 ~O F16 ~P Shift F13 ~Q		

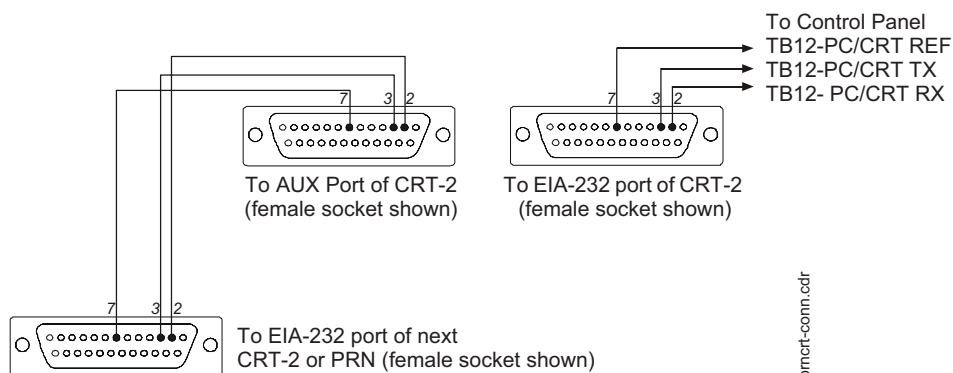
**Table 3.8 Standard CRT-2 Settings for Use with NFS2-640/E**

### 3.13.5 Connecting Multiple Printers, CRTs, or CRT/PRN Combination

Connecting multiple devices requires changing the CRT-2 setup using the F1(Quick) menu:

- Set Host/Printer=EIA/AUX.
- Set EIA Data Format=8/1/N.
- If the AUX device is a printer, set the Printer and AUX Data Format=7/1/E.
- If the AUX device is a second CRT-2, set the AUX Data Format=8/1/N.

Connect multiple devices as shown in Figure 3.29.



Note: For wire requirements, see Table B.1 in Appendix B “Electrical Specifications”.

**Figure 3.29 Connecting Multiple Devices on the EIA-232 Circuit**

## 3.14 Wiring a Signaling Line Circuit (SLC)

### ■ Overview

Communication between the control panel and intelligent and addressable initiating, monitor, and control devices takes place through a Signaling Line Circuit (SLC). You can wire an SLC to meet the requirements of NFPA Style 4, Style 6, or Style 7 circuits. This manual provides requirements and performance details specific to this control panel; for installation information and general information, refer to the *SLC Wiring Manual*.

### ■ Wiring

Maximum wiring distance of an SLC using 12 AWG (3.31 mm<sup>2</sup>) wire is 12,500 feet (3810 meters) total twisted-pair for Style 4, Style 6 and Style 7 circuits.

### ■ Capacity

The NFS2-640/E provides one (1) SLC, with a total capacity of 318 intelligent/addressable devices:

- 01-159 intelligent detectors
- 01-159 monitor and control modules

An optional expander board provides one (1) additional SLC, with the same capacity.

Units employing multiple detector operation shall include a minimum of two detectors in each protected space and reduce the detector installation spacing to 0.7 times the linear spacing in accordance with National Fire Alarm Code, NFPA. For spacing requirements refer to the detector’s installation instruction.



**NOTE:** To meet the ten-second response time required by UL 864, 9th edition, when SLC loops are configured to run in CLIP mode, all input modules must be set to address 19 or lower on both loop one and 2. There are no limits to detectors or output modules.

### ■ Installation

This control panel supports one or two SLC loops; a second SLC loop is obtained by installing an LEM-320 module. SLC loop #1 connects to TB13 on the control panel; SLC loop #2 connects to TB1 on the LEM-320. For details on designing, installing and configuring SLC loops, see the *SLC Wiring Manual*.

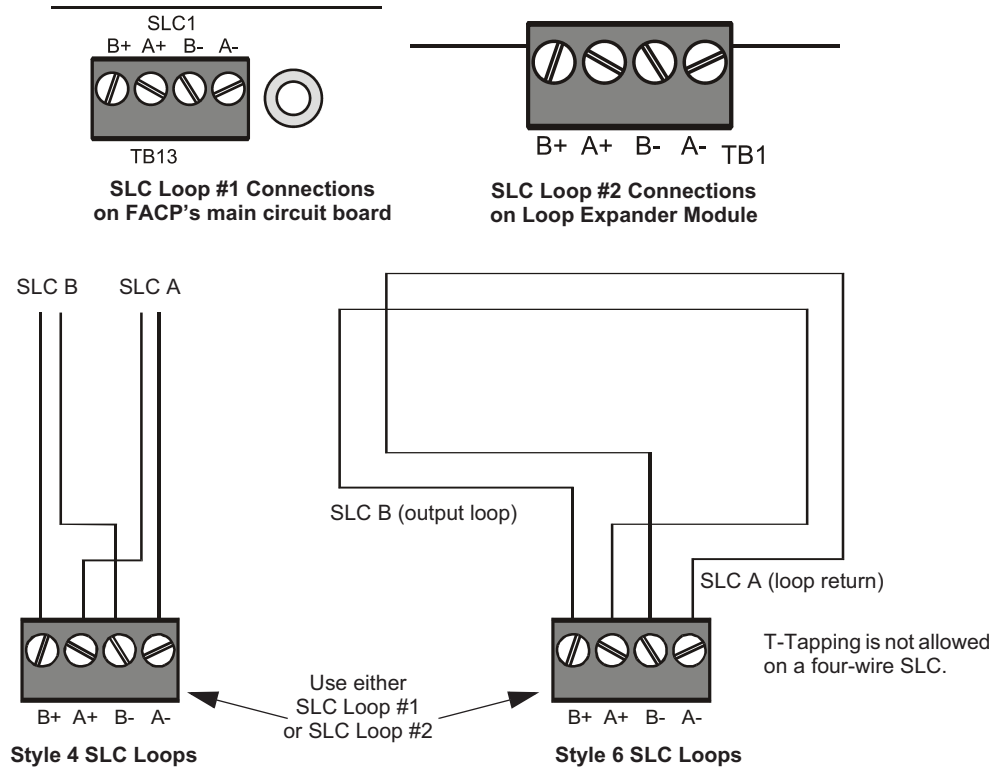


Figure 3.30 SLC Loop Connections and Wiring

## 3.15 Connecting a PC for Off-Line Programming

A PC can be hooked up to the control panel to allow the VeriFire Tools programming utility to upload and download the operating program. Refer to the insert in the VeriFire Tools CD insert and to the program's on-line help function for instructions. There are two options for connection:

1. For PCs with USB Ports, connect the PC to USB B via a standard USB B cable.
2. For PCs without USB Ports, connect the PC's serial port to the Control Panel Network/Service Connection (J1, NUP).



**NOTE:** Download operations that change the basic program of the control panel must be performed by responsible service personnel in attendance at the control panel. After downloading a program, test the control panel in accordance with NFPA 72.

# Section 4: Applications

## 4.1 Overview

Chapter	Covers the following topics
Section 4.3 "NFPA 72 Central or Remote Station Fire Alarm System (Protected Premises Unit)"	How to install UDACT with the control panel for use as a NFPA Central or Remote Station Fire Alarm System (Protected Premises Unit)
Section 4.4 "NFPA 72 Proprietary Fire Alarm Systems"	How to set up a Protected Premises Unit to communicate with a listed compatible Protected Premises Receiving Unit.
Section 4.5 "Fire/Security Applications"	How to use the control panel as a combination Fire/Security system, including the following: <ul style="list-style-type: none"> <li>• Installing a Security Tamper Switch into the cabinet</li> <li>• Circuit Wiring</li> </ul>
Section 4.6 "Releasing Applications"	How to install the following releasing applications: <ul style="list-style-type: none"> <li>• Releasing Device to the Control Panel (NAC integral circuits)</li> <li>• Releasing Device to the FCM-1 Module</li> <li>• NBG-12LRA Agent Release-Abort Station</li> </ul>

### Municipal Box (Auxiliary)

Municipal Box applications require a TM-4 Transmitter module. Refer to the *TM-4 Transmitter Module* installation document for installation details.

## 4.2 Devices Requiring External Power Supervision

With software version 12.0 or higher, certain type codes have external power supervision (FlashScan only) built into the software. An external power-supervision relay is required (see Figure 4.1) unless one of the following typecodes is selected for the device:

- Control
- Strobe
- Horn
- (Blank)
- Release Ckt
- Rel Ckt Ulc
- Nonreset Ctl
- Alarms Pend
- Gen Alarm
- Gen Supervis
- Gen Trouble
- Gen Pend
- Trouble Pend

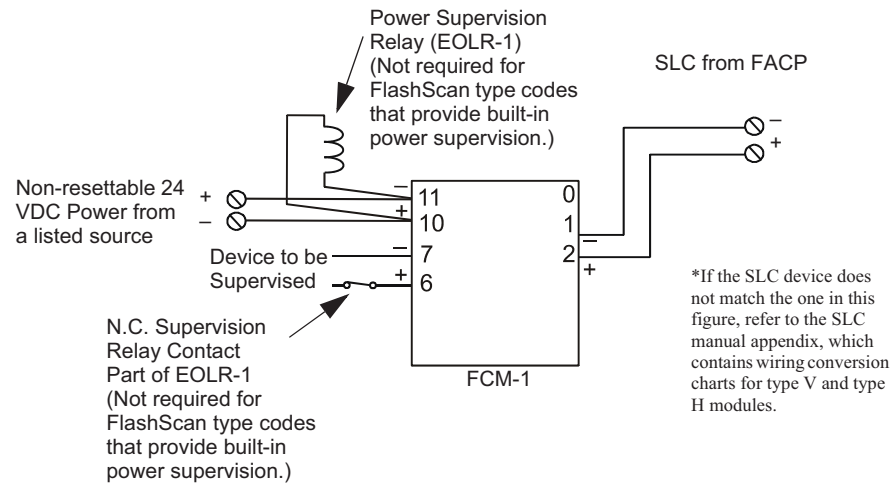


Figure 4.1 Enabling External Power Supervision Using Relays

### 4.3 NFPA 72 Central or Remote Station Fire Alarm System (Protected Premises Unit)

Figure 4.2 shows typical wiring diagram for a NFPA 72 Central Station Fire Alarm System (Protected Premises Unit) or a Remote Station Fire Alarm System (Protected Premises Unit) using the Universal Digital Alarm Communicator/Transmitter (UDACT) and control panel. This provides typical wiring only; connect and program the UDACT according to the directions given in the *UDACT Instruction Manual*.



**NOTE:** An NFPA 72 Central Station or Remote Station requires 24 hours of standby power and 5 minutes in alarm.



**NOTE:** This application can also be done with the TM-4 Transmitter; refer to the *TM-4 Transmitter Module* installation document for more details.



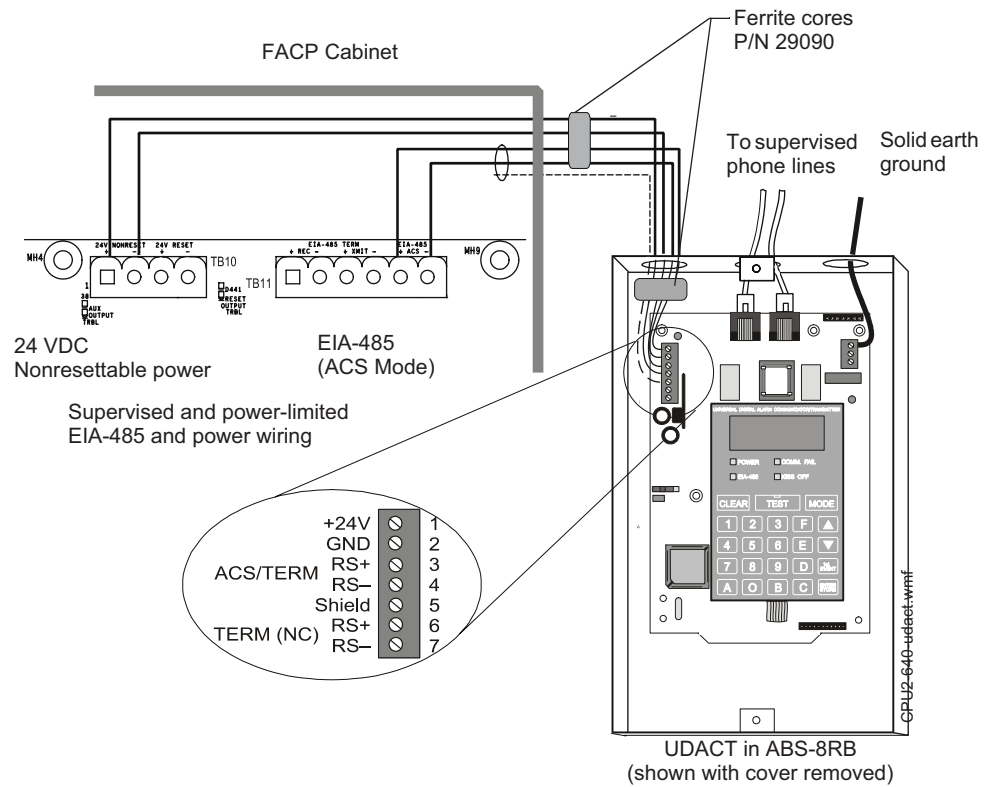


Figure 4.2 Typical Wiring Diagram for a Central Station Fire Alarm System



**NOTE:** Install a UL-listed 120 ohm End-of-Line resistor (P/N 71244) UDACT TB1 terminals 3 and 4 if this is the last or only device on EIA-485 line.

## 4.4 NFPA 72 Proprietary Fire Alarm Systems

When connected and configured as a protected premises unit with UDACT, the NFS2-640/E will automatically transmit General Alarm, General Trouble, and General Supervisory signals to a listed compatible Protected Premises Receiving Unit. See the *UDACT Manual* for compatible receiving units. A simplified drawing of connections between the receiving unit and the NFS2-640/E protected premises unit is shown in Figure 4.3.

Connect the receiving unit to the protected premises unit as shown in Section 4.3 “NFPA 72 Central or Remote Station Fire Alarm System (Protected Premises Unit)”.

For information on installing and programming the Receiving unit, refer to the documentation for that control panel.

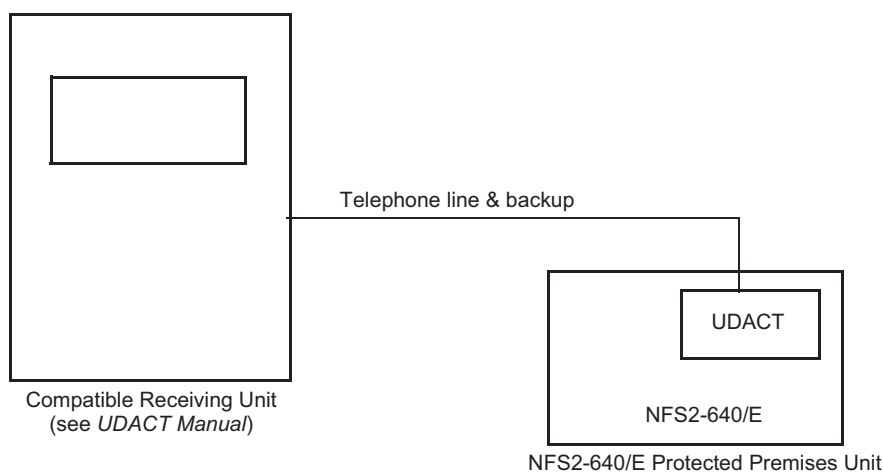


Figure 4.3 Typical Proprietary Fire Alarm Systems Wiring Connections

## 4.5 Fire/Security Applications



**NOTE:** NFS2-640/E is not approved for use in security applications in Canada.

### 4.5.1 General Operation

The control panel can be used as a combination Fire/Security system when installed and operated according to the instructions in this section.

For security applications, program one or more monitor modules (listed for security applications) with the SECURITY Type Code, and wire as shown in Figure 4.5. Activating this type of module lights the SECURITY LED, and displays a security alarm condition on the control panel LCD display. The panel sounder will sound until the Security alarm is acknowledged. You can also program additional sounders or output devices to activate with the security alarm initiating device. The SECURITY Type Code is designed to indicate an alarm as follows: (a) on an open or short circuit; or (b) on a  $\pm 50\%$  change in resistance value from the End-of-Line resistor value.

A tamper switch installed in the cabinet door will indicate a door tamper condition whenever the door is open. If the control panel indicates a Security alarm, you can acknowledge, silence, and reset the condition from the control panel.

When the system resets, a 30-second exit timer starts. During this time the tamper switch and all Security alarms are ignored. There is no entrance delay timer.

For bypass of security zones, use the DISABLE routine (covered in the *Status Change* section of the *NFS2-640/E Operations Manual*) for Security type devices.



**WARNING:**  
Damage can result from incorrect wiring connections.

### 4.5.2 Installing a Security Tamper Switch

To wire the cabinet with a Security Tamper Switch kit model STS-1, refer to Figure 4.4:

1. Install the STS-1 Tamper Switch onto the side of the backbox opposite the door hinge, pushing the switch through the opening until it snaps into place.

2. Install the magnet on the same side of the cabinet door as the lock. Push the magnet through the opening in the door until it snaps into place.
3. Connect the STS-1 connector to J5 (Security Tamper) on the Control Panel. (As shown in Figure 4.4, J5 is located on the circuit board, underneath the edge of KDM-R2.)

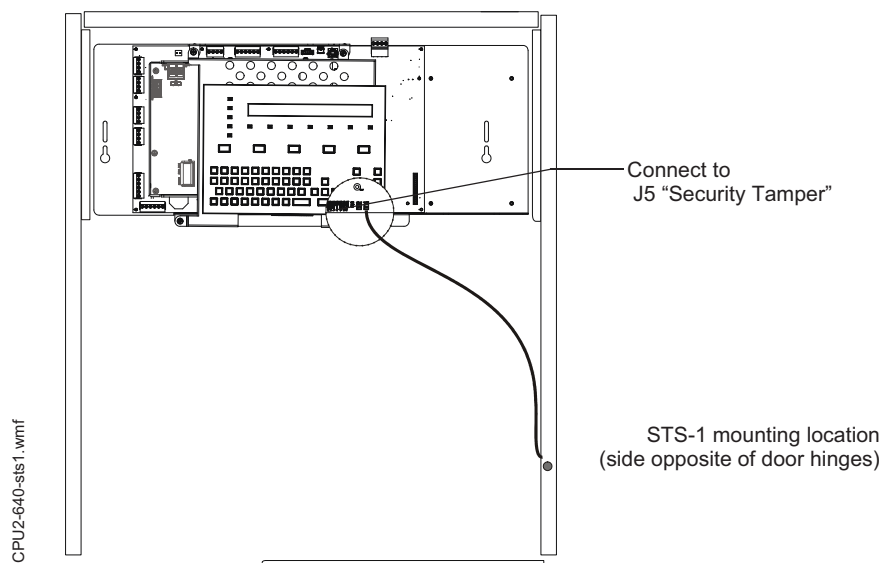


Figure 4.4 Installing the STS-1 Security Tamper Switch

### 4.5.3 Receiving Unit

For applications requiring transmission of security alarm information to a central receiving unit, the control panel may be connected via the UDACT to a compatible receiving unit (see the *UDACT Manual*). For information on configuring the Receiving unit for Combination Fire/Security applications, refer to the documentation for that control panel.

### 4.5.4 Programming

The control panel can communicate with any number of security devices. To do so, program the points as follows:

1. Select the address of the module(s) to be used for security.
2. Select the Type Code SECURITY.

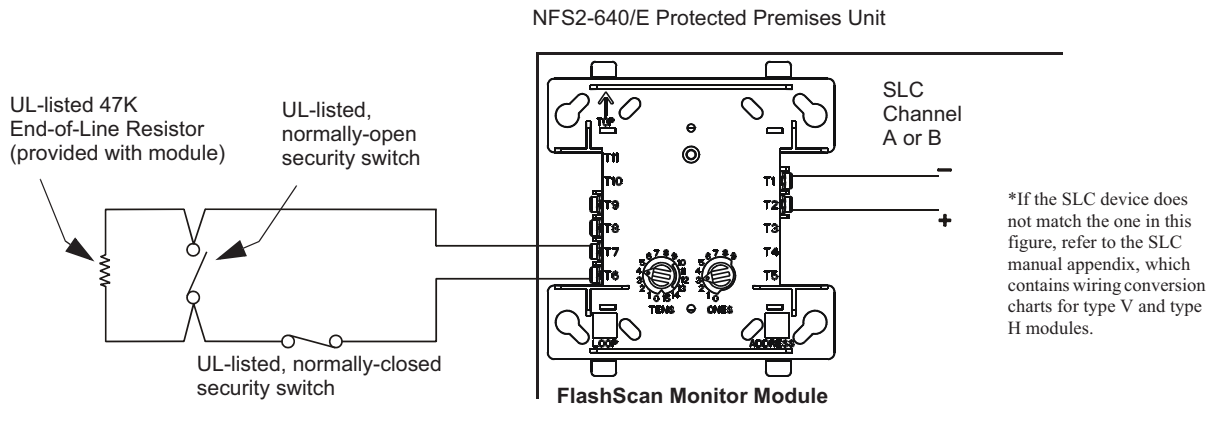


**NOTE:** For detailed instruction on programming Type Codes, refer to the NFS2-640/E *Programming Manual*.

### 4.5.5 Wiring for Proprietary Security Alarm Applications

Table 4.5 shows typical wiring for proprietary security alarm applications with FMM-1 modules. Note the following:

- The module is programmed with software SECURITY Type Code.
- For use with UL listed systems only; application not for ULC security usage.
- NAC devices used for security cannot be shared with fire NAC devices.
- Refer to the *Device Compatibility Document* for compatible NAC devices.
- All monitor modules used for security application must be installed in the NFS2-640/E cabinet with STS-1 Security Tamper Switch.



CPU2-640-burgipH.wmf

**Figure 4.5 Wiring Diagram for Proprietary Security Alarm Applications**

## 4.6 Releasing Applications



**WARNING:**

When used for CO<sub>2</sub> releasing applications, observe proper precautions as stated in NFPA 12. Do not enter the protected space unless physical lockout and other safety procedures are fully completed. Do not use software disable functions in the panel as lockout.



**WARNING:**

Do not enable the BACKUP option switch for any of the four Notification Appliance Circuits (NACs) if they are used for releasing functions!

### 4.6.1 Overview

This control panel can be used for agent release or preaction/deluge control applications. In a properly configured system with compatible, listed actuating and initiating devices, this control panel complies with the following NFPA standards for installation in accordance with the acceptable standard:

Standard	Covers
NFPA 12	CO <sub>2</sub> Extinguishing Systems
NFPA 12A	Halon 1301 Extinguishing Systems
NFPA 13	Sprinkler Systems
NFPA 15	Water Spray Systems
NFPA 16	Foam-Water Deluge and Foam-water Spray Systems
NFPA 17	Dry Chemical Extinguishing Systems
NFPA 17A	Wet Chemical Extinguishing Systems
NFPA 2001	Clean Agent Fire Extinguishing Systems

**Table 4.1 NFPA Standards for Releasing Applications**

To locate your specific releasing applications, including type codes and wiring diagrams, see the checklist in Table 4.2:

Refer to
Section 4.6.2 "Programming"
Section 4.6.3 "Connecting a Releasing Device to the Control Panel".
Section 4.6.4 "Connecting a Releasing Device to the FCM-1 Module (Retrofit applications only)".
Section 4.8 "Connecting an NBG-12LRA Agent Release-Abort Station".

**Table 4.2 Locating Specific Releasing Application Details in This Manual**

## 4.6.2 Programming

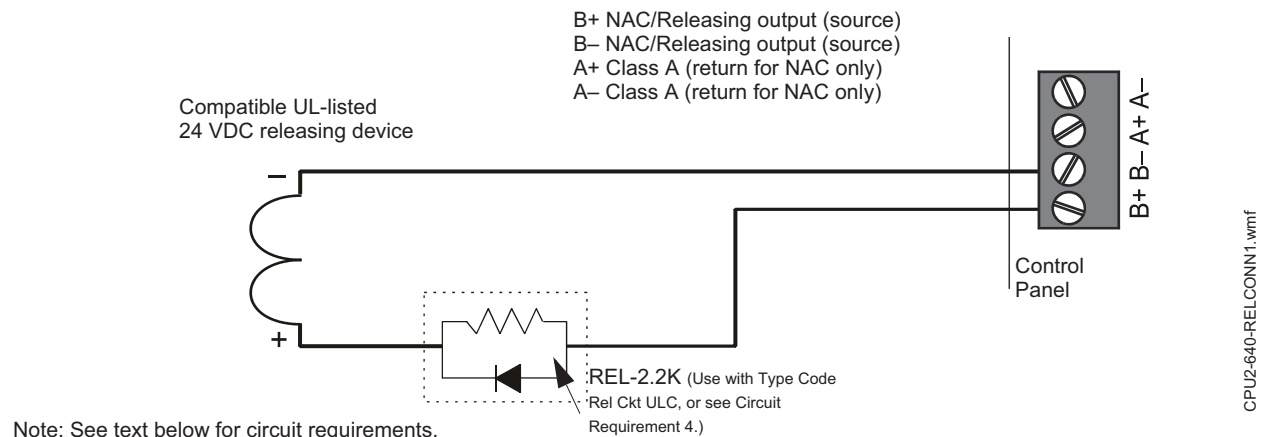
The control panel supports up to ten releasing software zones. You can map these zones to activate Control Panel releasing outputs and FCM-1 modules. Program the FCM-1 module for the appropriate type code according to the chart below:

Type Code: RELEASE CKT	Type Code: REL CKT ULC
<ul style="list-style-type: none"> <li>• For use in UL applications.</li> <li>• Do not use REL device at the solenoid.</li> <li>• Cannot use power-limited wiring.</li> <li>• Supervised for open circuit only.</li> <li>• Supervised for power loss with power-supervision relay.</li> </ul>	<ul style="list-style-type: none"> <li>• For use in UL or ULC applications.</li> <li>• Requires REL device at solenoid.</li> <li>• Power-limited wiring.</li> <li>• Supervised for open circuit and shorts.</li> <li>• Supervised for power loss with power-supervision relay.</li> </ul>

For more information, refer to the *NFS2-640/E Programming Manual*.

## 4.6.3 Connecting a Releasing Device to the Control Panel

Use TB6 (NAC#4), TB7 (NAC#3), TB8 (NAC#2), or TB9 (NAC#1) on the control panel for NAC/Releasing Circuits. The releasing circuit must be supervised and use listed, compatible releasing devices; see Figure 4.7–Figure 4.9 (page 54).



**Figure 4.6 Typical Style 4 Connection of a Releasing Device to Control Panel**



### WARNING:

Do not enable the BACKUP option switch for any of the four Notification Appliance Circuits (NACs) if they are used for releasing functions!

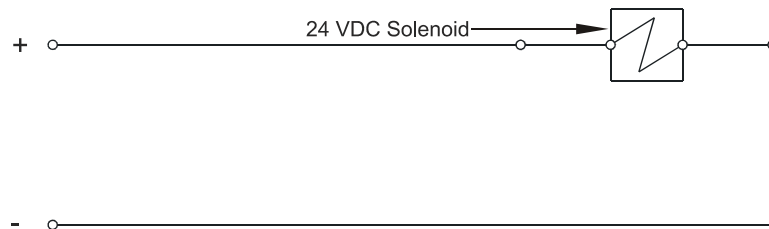
**Circuit Requirements.** When connecting a releasing device, note the following:

1. The control panel provides four NAC/Releasing Circuits (Style Y or Z). Each circuit can provide 1.5 A. Total current drawn from the power supply cannot exceed 7.4 A in an alarm condition (refer to Table A.2, “System Draw Current Calculations,” on page 63). Use compatible UL-listed 24 VDC appliances only. For more information on compatible appliances, refer to the *Device Compatibility Document*.
2. Refer to the Releasing Applications appendix in the *NFS2-640/E Programming Manual* for configuration details (such as setting the Soak Timer).
3. For applications using power-limited circuits:
  - a) Use an in-line supervisory device (P/N REL-2.2K) with control panel releasing circuits. Connect the End-of-Line device as shown in Figure 4.6.

- b) Program the releasing circuit for Type Code REL CKT ULC.
- c) Circuits are supervised against opens and shorts.
- 4. For applications not requiring power-limited circuits –
  - a) If the application does not require supervising the releasing device against shorts, in-line supervisory devices (P/N REL-2.2K) are not required.
  - b) In non-power-limited applications, program the releasing circuit for Type Code RELEASE CKT.
  - c) Limited energy cable cannot be used to wire a non-power-limited releasing device circuit
  - d) Maintain a 0.25 inch (6.35 mm) spacing between the non-power-limited releasing circuit device wiring and any power-limited circuit wiring.)
- 5. The releasing circuit must be programmed with a releasing type code listed in the *NFS2-640/E Programming Manual*.

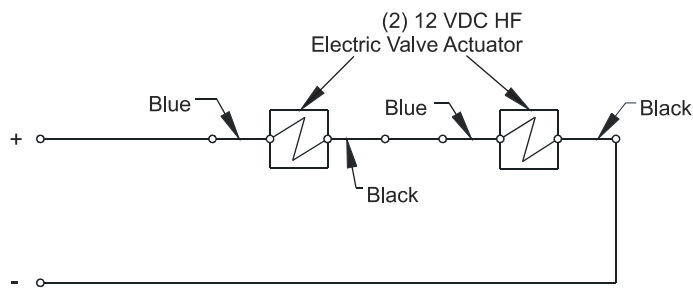


**NOTE:** As per UL 864 9<sup>th</sup> Edition, a supervisory signal must be indicated at the panel whenever a releasing circuit is physically disconnected. Use a monitor module to monitor dry contacts off the switch. See 4.10.



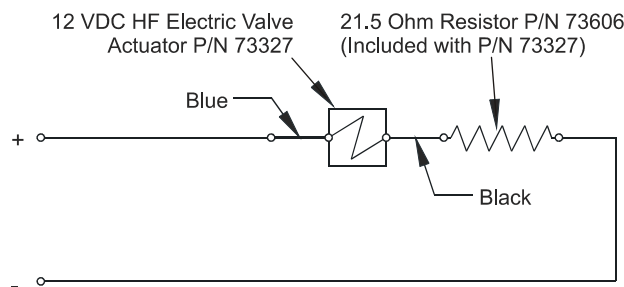
IOActuatora.wmf

**Figure 4.7 Releasing Circuits (Option 1)**



:tuatorsb.wmf

**Figure 4.8 Releasing Circuits (Option 2)**



IOActuatorb.wmf

**Figure 4.9 Releasing Circuits (Option 3)**



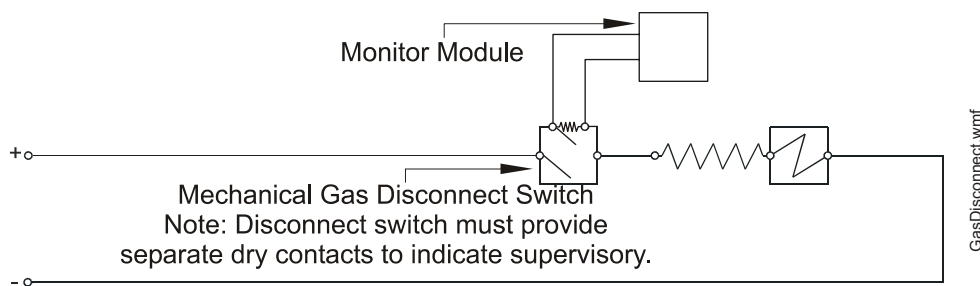
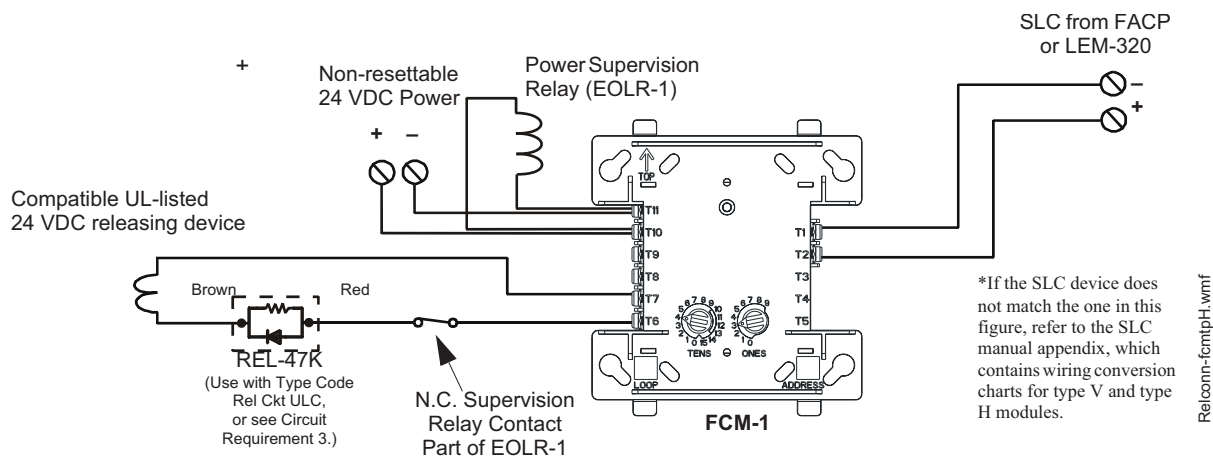


Figure 4.10 Release Circuits (Mechanical Gas Disconnect Switch)

#### 4.6.4 Connecting a Releasing Device to the FCM-1 Module (Retrofit applications only)

The module can control 1 A of current. Make sure to keep total system current within the limits of the power supply. You can power the module from the power supply of the Control Panel or any UL/ULC listed 24 VDC regulated power-limited power supply for Fire Protective Signaling. For more information, refer to the *Device Compatibility Document*.



Note: See text for circuit requirements.

Figure 4.11 Typical Connection of a 24 VDC Releasing Device to the FCM-1 Module

**Circuit Requirements** When connecting a releasing device to the FCM-1 module, note the following:

1. Refer to the Releasing Applications appendix in the *NFS2-640/E Programming Manual* for configuration details (such as setting the Soak Timer).
2. For applications using power-limited circuits:
  - a) Use an in-line supervisory device (P/N REL-47K) with the FCM-1 module. Connect the in-line supervisory device as shown in Figure 4.11.
  - b) Program the releasing circuit for Type Code REL CKT ULC.
  - c) Circuits are supervised against opens and shorts.
3. For applications not requiring power-limited circuits:
  - a) In-line supervisory devices (P/N REL-47K) are not required; however, the releasing device circuit is not supervised against shorts.
  - b) In non-power-limited applications, program the releasing circuit for Type Code RELEASE CKT.
  - c) Limited energy cable cannot be used to wire a non-power-limited releasing device circuit.

d) Maintain a 0.25 inch (6.35 mm) spacing between the non-power-limited releasing circuit device wiring and any power-limited circuit wiring.



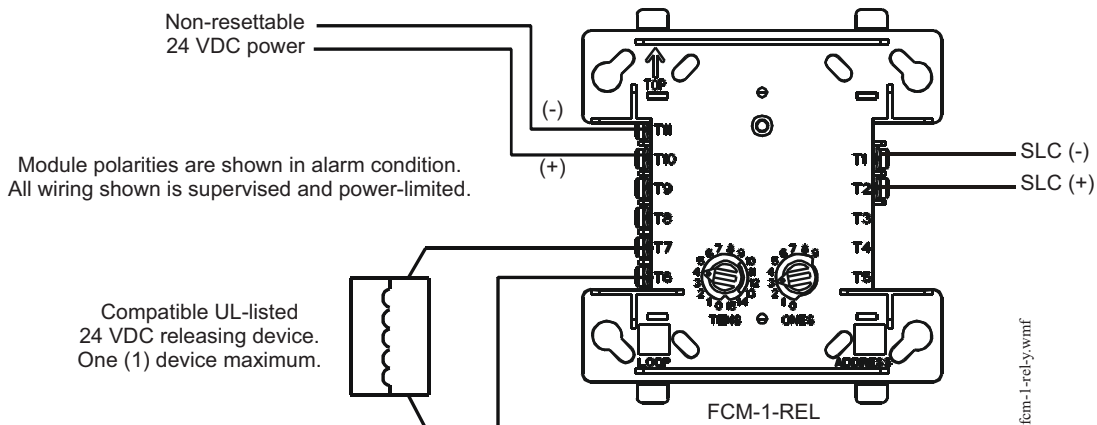
**WARNING:**  
The XP6-C is not listed for releasing applications and cannot be substituted for FCM-1



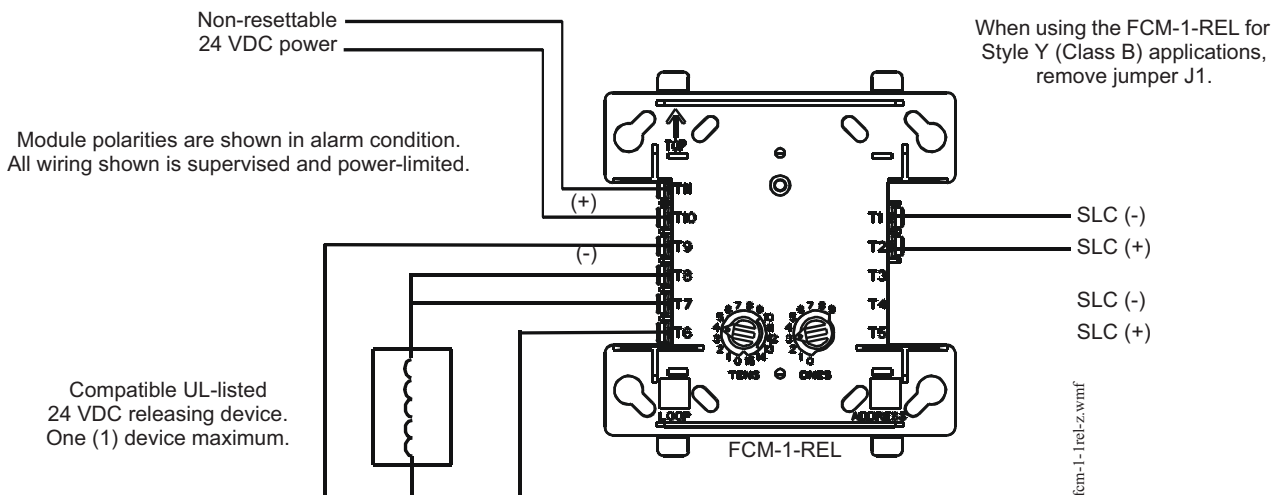
**NOTE:** As per UL 864 9th Edition, a supervisory signal must be indicated at the panel whenever a releasing circuit is physically disconnected. Use a monitor module to monitor dry contacts off the switch. See 4.10.

## 4.7 Connecting Releasing Devices to the FCM-1-REL Control Module

**Typical Connections** Figure 4.12 and Figure 4.13 show typical connections for wiring a releasing device to the FCM-1-RELs. Refer to the Device Compatibility Document for compatible releasing devices.



**Figure 4.12 NPFA Style Y (Class B) Wiring of the FCM-1-REL**



**Figure 4.13 NPFA Style Z (Class A) Wiring of the FCM-1-REL**

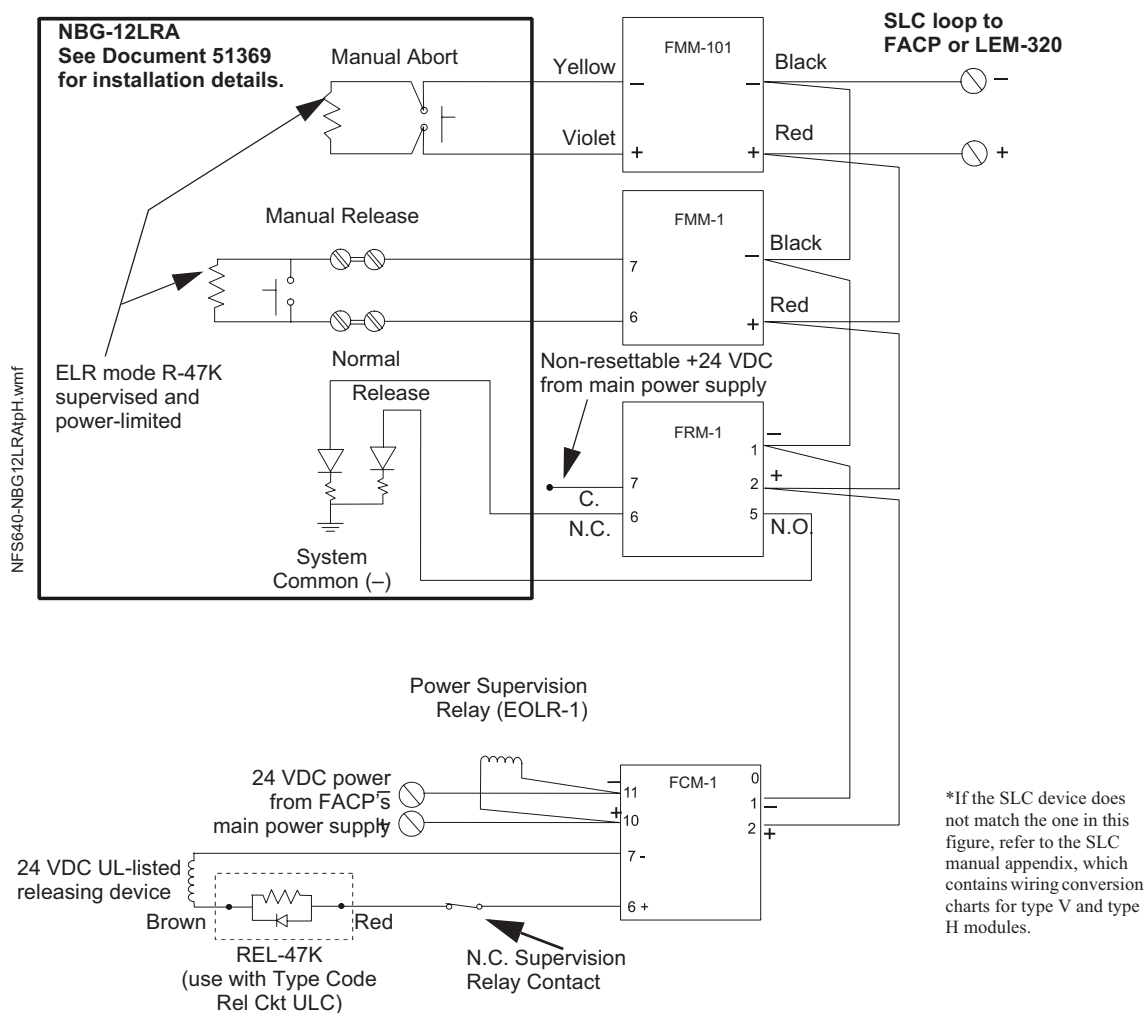
**NOTE:** With software version 12.0 or higher ALL new SLC releasing applications require the FCM-1-REL control module. The V-type FCM-1 control module may be used in SLC releasing applications with software version 12.0 or higher in retrofit applications only. H-type FCM-1 control modules do not support releasing applications with software version 12.0 or higher.

**Critical Requirements.** When connecting a releasing device to the FCM-1-REL module, note the following:

1. See “Power Considerations” on page 52 for information on monitoring 24 VDC power.
2. Do not T-tap or branch a Style Y or Style Z circuit.
3. Only one (1) 24V solenoid or two (2) 12V solenoids in series can be connected to the FCM-1-REL.
4. Do not loop wiring under the screw terminals. Break the wire run to provide supervision of connections.
5. All applications using the FCM-1-REL are power-limited:
  - a. Program the releasing circuit for Type Code REL CKT ULC or RELEASE CKT.
  - b. Circuits are supervised against opens and shorts.
6. Refer to the NFS2-640 *Programming Manual* for instructions on setting the Soak Timer.

The FCM-1-REL module must be programmed with the correct releasing type code listed in the *NFS2-640 Programming Manual*.

### 4.8 Connecting an NBG-12LRA Agent Release-Abort Station



**Figure 4.14 Typical Connections for an NBG-12LRA Agent Release-Abort Station**



---

**NOTE:** If using the on-board NACs, see Circuit Requirements for Section 4.6.3 “Connecting a Releasing Device to the Control Panel” on page 53. If using FCM-1, see Circuit Requirements for Section 4.6.4, “Connecting a Releasing Device to the FCM-1 Module (Retrofit applications only)”, on page 55. If using the FCM-1-REL, see Circuit Requirements for Section 4.7, “Connecting Releasing Devices to the FCM-1-REL Control Module”, on page 56.

---

# Section 5: Testing the System

## 5.1 Acceptance Test

When finished with the original installation and all modifications, conduct a complete operational test on the entire installation to verify compliance with applicable NFPA standards. Testing should be conducted by a factory-trained fire alarm technician in the presence of a representative of the Authority Having Jurisdiction and the owner's representative. Follow procedures outlined in NFPA Standard 72's section on *Inspection, Testing and Maintenance*.

## 5.2 Periodic Testing and Service

Periodic testing and servicing of the control panel, all initiating and notification devices, and any other associated equipment is essential to ensure proper and reliable operation. Test and service the control panel according to the schedules and procedures outlined in the following documents:

- NFPA Standard 72's section on *Inspection, Testing and Maintenance*.
- Service manuals and instructions for the peripheral devices installed in the system. Correct any trouble condition or malfunction immediately.

## 5.3 Operational Checks

Between formal periodic testing and servicing intervals, the following operation checks should be performed monthly, or more frequently when required by the Authority Having Jurisdiction.

- o Before proceeding: a) notify the fire department and the central alarm receiving station if transmitting alarm conditions; b) notify facility personnel of the test so that alarm sounding devices are disregarded during the test period; and c) when necessary, disable activation of alarm notification appliances and speakers to prevent their sounding.
- o Disconnect all releasing devices to prevent accidental activation in accordance with NFPA 2001 and NFPA 12A releasing agents.



**WARNING:**

Do not rely on disable/enable software settings to lockout releasing devices.

---

- o Check that the green POWER LED lights.
- o Check that all status LEDs are off.
- o Press and hold the LAMP TEST key. Verify that all LEDs and all LCD display segments work.
- o Activate an Initiating Device Circuit using an alarm initiating device or an addressable initiating device on the SLC and check that all programmed active notification appliances function. Reset the alarm initiating device, the control panel, and any other associated equipment. In voice alarm applications, confirm that the proper tone(s) and/or messages sound during alarm conditions. Select the paging function and confirm that the message can be heard in the affected fire zones. Repeat the above step with each Initiating Device Circuit and each addressable device.
- o On systems equipped with a fire fighter's telephone circuit, make a call from a telephone circuit and confirm a ring tone. Answer the call and confirm communication with the incoming caller. End the call and repeat for each telephone circuit in the system.
- o Remove AC power, activate an Initiating Device Circuit through an alarm initiating device or an addressable initiating device on the SLC, and check that programmed active notification

*Continued on next page...*

appliances sound, and alarm indicators illuminate. Measure the battery voltage with notification appliances active. Replace any battery with a terminal voltage less than 21.6 VDC and reapply AC Power.



---

**NOTE:** The battery test requires fully charged batteries. If batteries are new or discharged due to a recent power outage, allow the batteries to charge for 48 hours before testing.

---

- o Return all circuits to their pretest condition.
- o Check that all status LEDs are off and the green POWER LED is on.
- o Notify fire, central station and/or building personnel when you finish testing the system.

## 5.4 Battery Checks and Maintenance

Maintenance-free sealed lead-acid batteries used in the system do not require the addition of water or electrolyte. These batteries are charged and maintained in a fully charged state by the main power supply's charger during normal system operation. A discharged battery typically reaches the voltage of 27.6 VDC within 48 hours; the charge rate depends on the battery size (2.0A for 18-26AH; 5.0A-5.7A for 26AH-200AH).

Sealed lead-acid batteries must be replaced within at most 5 years from their date of manufacture. Minimal replacement battery capacity appears on the control panel marking label. Immediately replace a leaking or damaged battery. You can get replacement batteries from the manufacturer.



---

**WARNING:**

Batteries contain Sulfuric Acid which can cause severe burns to the skin and eyes and damage to fabrics.

---

- If a battery leaks and contact is made with the Sulfuric Acid, immediately flush skin and/or eyes with water for at least 15 minutes. Water and household baking soda provides a good neutralizing solution for Sulfuric Acid.
- If Sulfuric Acid gets into eyes, seek immediate medical attention.
- Ensure proper handling of the battery to prevent short circuits.
- Take care to avoid accidental shorting of the leads from uninsulated work benches, tools, bracelets, rings, and coins.



---

**WARNING:**

Shorting the battery leads can damage the battery, equipment, and could cause injury to personnel.

---



# Appendix A: Power Supply Calculations

Calculations must be done to determine standby and alarm DC current loads. Ampere-hour requirements must be calculated as well to determine battery size.

The on-board power supply provides filtered 24VDC power that may be used for operating external devices. Use Table A.2 to determine if external loading is within the capabilities of the power supply.

## A.1 Calculating AC Branch Circuit Current

Use Table A.1 below to determine the total amount of current, in AC amperes, that a 120 VAC, 50/60 Hz service must be able to supply to the fire alarm system. Devices rated for 240 VAC operation will draw approximately one-half the current listed in Table A.1.

Device Type	No. of Devices		Current (amps)		Total Current
CPS-24 Power Supply	[ 1 ]	X	5.0	=	5.0
CPS-24/E Power Supply	[ .. ]	X	2.5A	=	
AA-30	[ ]	X	1.00	=	
AA-120	[ ]	X	1.85	=	
FCPS-24S6/S8	[ ]	X	3.2	=	
ACPS-2406	[ ]	X	2.7	=	
ACPS-610	[ ]	X	5.0	=	
ACPS-610/E	[ ]	X	2.5	=	
APS-6R	[ ]	X	2.5	=	
CHG-120	[ ]	X	2.0	=	
Sum column for AC Branch Current required=amps					

**Table A.1 120 VAC Fire Alarm Circuit**

- \* Separate calculations are required for any devices powered by the ACPS-2406 and ACPS-610. It has its own integral battery charger and batteries can be connected directly to it. Refer to the *ACPS-2406 or ACPS-610 Installation Manuals* for battery calculations.

### AC Branch Circuit Installation

For guidelines on wiring the AC branch circuit current, see “Operating Power: AC Branch Circuit” on page 69 in Appendix B.1 “Electrical Specifications”.

## A.2 Calculating the System Current Draws

The control panel’s main power supply must be able to power all internal system devices (and several types of external devices) continuously during non-fire alarm conditions. Use column 1 in Table A.2 to calculate the Non-Fire Alarm Load on the power supply regulator when applying primary power. The main power supply must also provide a finite amount of additional current during a fire alarm condition. Use column 2 in Table A.2 to calculate the additional current needed during fire alarms. The requirements for non-fire alarm and fire alarm current loads cannot exceed the capabilities of the power supply as listed below:

- 4.4 A at 24 VDC during Standby; and
- 7.4 A at 24 VDC during Alarm.

The current draw from all NACs plus DC output from TB10 and TB2 is 3.0 A during standby.

## How to Use the Calculating Tables

As used in this section, “Primary” refers to the control panel’s on-board power supply, its primary source of AC power. “Secondary” refers to the control panel’s backup batteries (or any other 24 VDC power supply listed for Fire Protective Signaling and connected in place of the batteries). The term “standby” refers to the output current required when no fire alarm is present. The term “alarm” refers to the output current required when a fire alarm is present.

The Primary Power Source Non-Alarm Current and Alarm Current columns are DC current calculations. These calculations confirm that the power supply can provide enough current to support the system during Primary Non-Fire Alarm and Fire Alarm conditions.

**Quantities** List the number of devices powered by the FACP and its power supply. Devices powered by the Accessories Output (TB10 and TB2) draw current directly from the panel. Devices powered by the Panel Output draw current through the fire panel’s connection to the power supply. Use these quantities to calculate total current draw of each set of devices in calculation columns 1, 2, and 3.

**Calculation Column 1 (Primary, Non-Fire Alarm Current in amps)** Add the contents of calculation column 1 to get the current drawn from the power supply during a non-alarm condition, with AC power applied. This current draw cannot exceed 4.4 A without an auxiliary power supply.

**Calculation Column 2 (Primary, Fire Alarm Current in amps)** Calculation column 2 lets the system designer determine the current load that the power supply must support during a fire alarm. The total current draw during a fire alarm cannot exceed 6 A without an auxiliary power supply.

Typically, a system should contain capacity to activate all output circuits and relays, and support fire alarms on no less than 10% of Initiating Device Circuits, subject to the requirements of the Authority Having Jurisdiction (AHJ).

The Control Panel provides power for Notification Appliance Circuits. Refer to the Device Compatibility Document for 24 VDC notification appliances that are UL- and ULC-listed for fire alarm systems.

**Calculation Column 3 [Secondary (Battery) Non-Alarm Current]** Column 3 lets the system designer calculate the non-fire alarm current drawn from the secondary source in a non-fire alarm condition during AC power loss. The non-fire alarm current is required to complete the standby battery calculations. After summing all current draws, insert the total in Table A.3.

Category	Calculation Column 1 Primary, Non-Fire Alarm Current (amps)			Calculation Column 2 Primary, Fire Alarm Current (amps)			Calculation Column 3 Secondary, Non-Fire Alarm Current (amps)		
	Qty	X [current draw]=	Total	Qty	X [current draw]=	Total	Qty	X [current draw]=	Total
CPU2-640/E # NACs in use (0, 1, 2, 3 or 4)*	1 [ ]	x [0.250]= x [0.035]		1 [ ]	x [0.250]= x [0.035]		1 [ ]	x [0.250]= x [0.035]	
CPS-24/E	n/a	n/a		n/a	n/a		n/a	x [0.040]	
KDM-R2 (Backlight on)	[ ]	x [0.100]=		[ ]	x [0.100]=		[ ]	x [0.100]=	
LEM-320	0 / 1	x [0.100]=		0 / 1	x [0.100]=		0 / 1	x [0.100]=	
SLC loop†:	0/1/2			0/1/2			0/1/2		
with jumper JP2 cut on CPU or without jumper JP2 cut on CPU		x [0.200]= x [0.400]=			x [0.200]= x [0.400]=			x [0.200]= x [0.400]=	
NCA, NCA-2 (Back light ON)	[ ]	x [0.400]=		[ ]	x [0.400]=		[ ]	x [0.400]=	
NCA, NCA-2 (Back light OFF)	[ ]	x [0.200]=		[ ]	x [0.200]=		[ ]	x [0.200]=	
NCM-W, NCM-F	[ ]	x [0.110]=		[ ]	x [0.110]=		[ ]	x [0.110]=	
TM-4	[ ]	x [0.110]=		[ ]	x [0.175]=		[ ]	x [0.110]=	
DPI-232 (Refer to manual**)	[ ]	x [ ]=		[ ]	x [ ]=		[ ]	x [ ]=	
APS-6R							[ ]	x [0.025]=	
ACPS-2406, ACPS-610							[ ]	x [0.0013]=	
DVC components (Refer to manual**)	[ ]	x [ ]=		[ ]	x [ ]=		[ ]	x [ ]=	
	[ ]	x [ ]=		[ ]	x [ ]=		[ ]	x [ ]=	
AA-30							[ ]	x [0.045]=	
AA-100, AA-120							[ ]	x [0.050]=	
ACM-24AT	[ ]	x [0.016]=		[ ]	x [0.070]=		[ ]	x [0.016]=	
ACM-48A	[ ]	x [0.016]=		[ ]	x [0.070]=		[ ]	x [0.016]=	
AEM-24AT	[ ]	x [0.002]=		[ ]	x [0.056]=		[ ]	x [0.002]=	
AEM-48A	[ ]	x [0.002]=		[ ]	x [0.056]=		[ ]	x [0.002]=	
Maximum number of LEDs illuminated on these annunciators during non-fire conditions:	[ ]	x [0.0054]=					[ ]	x [0.0054]=	
AFM-16AT, AFM-32A	[ ]	x [0.040]=		[ ]	x [0.056]=		[ ]	x [0.040]=	
ACM-16AT, ACM-32A	[ ]	x [0.040]=		[ ]	x [0.056]=		[ ]	x [0.040]=	
AEM-16AT, AEM-32A	[ ]	x [0.002]=		[ ]	x [0.018]=		[ ]	x [0.002]=	
AFM-16A	[ ]	x [0.025]=		[ ]	x [0.065]=		[ ]	x [0.025]=	
ACM-8R (refer to manual**)	[ ]	x [ ]=		[ ]	x [ ]=		[ ]	x [ ]=	
LDM (refer to manual**)	[ ]	x [ ]=		[ ]	x [ ]=		[ ]	x [ ]=	
FDU-80	[ ]	x [0.0643]=		[ ]	x [0.0643]=		[ ]	x [0.0643]=	
AMG-1, AMG-E	[ ]	x [0.060]=		[ ]	x [0.060]=		[ ]	x [0.060]=	
FFT-7, FFT-7S	[ ]	x [0.060]=		[ ]	x [0.120]=		[ ]	x [0.060]=	
RM-1	[ ]	x [0.020]=		[ ]	x [0.020]=		[ ]	x [0.020]=	
FZM-1, MMX-2	[ ]	x [0.0094]=		[ ]	x [0.090]=		[ ]	x [0.0094]=	
XPIQ (Refer to manual**)	[ ]	x [ ]=		[ ]	x [ ]=		[ ]	x [ ]=	
RPT-W, RPT-WF, RPT-F RPT-485W, RPT-485WF	[ ]	x [0.017]=		[ ]	x [0.017]=		[ ]	x [0.017]=	
UDACT Communicator NFV-25/50 (see manual**)	[ ]	x [0.040]=		[ ]	x [0.100]=		[ ]	x [0.040]=	
	[ ]	x [ ]=		[ ]	x [ ]=		[ ]	x [ ]=	
Four-Wire Smoke Detectors‡	[ ]	x [ ]=		[ ]	x [ ]=		[ ]	x [ ]=	
	[ ]	x [ ]=		[ ]	x [ ]=		[ ]	x [ ]=	
Power Supervision Relay EOLR-1	[ ]	x [0.020]=		[ ]	x [0.020]=		[ ]	x [0.020]=	
Notification Appliance powered from Main Power Supply††				[ ]	x [ ]=				
				[ ]	x [ ]=				
DHX-501, FSD-751RP, FSD-751RPL (Duct Detectors with internal relays) Refer to installation document	[ ]	x [ ]=		[ ]	x [ ]=		[ ]	x [ ]=	
	[ ]	x [ ]=		[ ]	x [ ]=		[ ]	x [ ]=	
CHG-120 Battery Charger							[ ]	x [0.060]=	
Local Energy Municipal Box									
Compatible Devices not listed above††	[ ]	x [ ]=		[ ]	x [ ]=		[ ]	x [ ]=	
	[ ]	x [ ]=		[ ]	x [ ]=		[ ]	x [ ]=	
Sum each column for totals		Primary, non-alarm:		Primary, alarm:		Secondary, non-alarm:			

**Table A.2 System Draw Current Calculations**

- \* Maximum current draw for all NACs plus DC output from TB10 and TB2 is 3.0 A during standby.
- † Value represents an SLC's maximum current draw. Refer to device datasheets for individual current draws. If jumper JP2 is cut, total device current cannot exceed 200 mA; if jumper JP2 is not cut, total device current cannot exceed 400 mA.
- ‡ The total regulated load current supplied to four-wire smoke detector and power supervision relays cannot exceed 1.25 A.
- \*\* Enter the total notification appliance draw from the Main Power Supply, excluding the current from APS-6R supplies. Refer to Device Compatibility Document.
- †† Refer to manual and/or Device Compatibility Document. See Table 1.1, "Reference Documentation," on page 8 for specific documentation part numbers.

## A.2.1 Calculating the Maximum Secondary Power Fire Alarm Current Draw

Use Table A.3 below to determine the maximum current requirements of secondary power source during fire alarm conditions. The result obtained is the amount of current that the batteries must be able to supply to the fire alarm system. Use the result in Table A.4 to determine the size of the batteries needed for the fire alarm system.

Results taken from Table A.3 below assume that, while in a fire alarm condition, batteries must feed the main power supply (and any additional supplies such as the APS-6R and AA-30) with the maximum rated power each supply can provide.

Device	Quantity		Current (in amps)	Total Current/Type
Alarm Current, from Table A.2, col 2			=	
APS-6R*	[ ]	X	6	=
AA-30†	[ ]	X	3	=
AA-120	[ ]	X	7.3	=
Sum Column for Secondary Fire Alarm Load			=	<input type="text"/>

**Table A.3 Maximum Secondary Power Fire Alarm Current Draw**

- \* Actual load current may be used in place of maximum rated supply current. To calculate actual load current, sum the current draws for each appliance connected to APS-6R supplies.
- † Exclude Amplifiers that are employed for backup.



**NOTE:** The Secondary Fire Alarm Load cannot exceed the following:  
 12 A with BAT-12250 batteries (12 V, 26 AH).  
 20 A with BAT-12550 batteries (12 V, 55 AH).

## A.3 Calculating the Battery Requirements

### A.3.1 Calculating the Battery Capacity

Use this table to determine the battery capacity needed for the system:

Current (amps)	X	Time (hours)	=	AH
Secondary Non-Fire Alarm Current (from column 3 in Table A.2) (see Note 8)		Required Secondary Non-Fire Alarm Standby Time (24 or 60 hours)		
_____	X	_____	=	_____ AH
APS-6R Standby Load Current		Required Secondary Non-Fire Alarm Standby Time (24 or 60 hours)		
_____	X	_____	=	_____ AH
Secondary Fire Alarm Load (from Table A.3) (see Note 8)		Required Fire Alarm Standby Time: (for 5 minutes, enter 0.084; for 15 minutes, enter 0.25)		
_____	X	_____	=	_____ AH
Sum Column for Total Secondary Amp Hours calculated			=	_____ AH
Multiply by the derating factor x 1.2 (see Note 7)			=	_____ AH
Battery Size – Total Secondary Amp Hours Required			=	_____ AH
<ol style="list-style-type: none"> <li>NFPA 72 Local, Proprietary, and Central Station systems require 24 hours of standby power followed by 5 minutes in alarm.</li> <li>NFPA 72 Auxiliary and Remote Station Systems require 24 hours of standby power followed by 5 minutes in alarm.</li> <li>Batteries installed in a system powered by an automatic starting engine generator need to provide at least 4 hours of standby power.</li> <li>Factory Mutual requires 90 hours of standby for deluge-preaction systems.</li> <li>Emergency voice/alarm communications systems require 2 hours of operation in the alarm condition. Due to the sporadic nature of voice operation, however, NFPA 72 permits 15 minutes of operation at a maximum connected load to equal 2 hours of normal use.</li> <li>If the total exceeds 26 AH, the system requires a separate NFS-LBB battery enclosure for two BAT-12550, 55 AH batteries in a separate NFS-LBB enclosure. If CHG-120 battery charger is used, it requires a second NFS-LBB enclosure.</li> <li>The following battery derating factors must be used for Canadian installations using NFS2-640/E charger: <ul style="list-style-type: none"> <li>For a 26 AH battery, use derating factor of 1.5</li> <li>For a 55 AH battery, use derating factor of 1.8</li> <li>For a 100 AH battery, use derating factor of 2.5</li> <li>For a 200 AH battery, use derating factor of 2.5</li> </ul> </li> <li>For 26 AH batteries: maximum standby current cannot exceed 0.65A; maximum alarm current cannot exceed 6.75A.</li> </ol>				

**Table A.4 Secondary Power Standby and Fire Alarm Load**

### A.3.2 Calculating the Battery Size

Use this table to choose the battery size, in amp-hours, needed to support the fire alarm system. The CPS-24/E can charge batteries from 18 to 200 AH. Select batteries that meet or exceed the Total Amp-Hours calculated in Table A.4 and that are within the acceptable battery charger range. Write the amp-hours requirements on the Protected Premises label.

The maximum battery size that can be mounted inside a CAB-4 series backbox is 26AH.

Battery Size	Voltage Rating	Number Required	Our Part Number	Backbox Part Number <sup>†</sup>
18 AH	12 volts	two	BAT-12180	SBB-A4*, SBB-B4*, SBB-C4*, SBB-D4*, BB-25
26 AH	12 volts	two	BAT-12260	SBB-A4, SBB-B4, SBB-C4, SBB-D4, BB-25
100 AH	12 volts	four for 100 AH two for 200 AH	BAT-121000	BB-100 BB-200
*Manufactured to our specifications.				
<sup>†</sup> Red version available; add "R" to part number listed here				

**Table A.5 Selecting Battery and Battery Backbox**



# Appendix B: Electrical Specifications

## B.1 Electrical Specifications

### AC Power

Component	Values
Main Power Supply	120 VAC, 50/60 Hz, 5.0 A; or 240 VAC, 50/60 Hz, 2.5 A
Wire size	Maximum 12 AWG (3.31 mm <sup>2</sup> ) with 600 VAC insulation



**NOTE:** If using an auxiliary power supply such as FCPS-24S6/S8, APS-6R, ACPS-2406, or ACPS-610, or audio amplifiers, refer to the documentation for that equipment.

### Batteries

The control panel uses **only** sealed lead-acid batteries for secondary standby power. Maximum battery capacity for the CPS-24/E main power supply is 200 AH. CAB-4 Series backboxes provide space for two 26 AH (or smaller) batteries. Use external battery boxes if the installation requires larger capacity batteries; see Table A.5, “Selecting Battery and Battery Backbox,” on page 66.

The table below contains battery charger specifications.

Charger	Description	Specifications
CPS-24/E Main Power Supply	An internal battery charger for 18 AH to 200 AH	Normal Charge: 27.6 VDC +/- 0.24 VDC Charging Current: 2.0 A or 5.7 A (Software selectable)
CHG-120 Battery Charger	An external battery charger designed to charge lead-acid batteries between 26 AH and 120 AH	Dual Rate: High Charge: 28.1 VDC Normal Charge: 27.6 VDC Charging Current: 4.5 A
ACPS-2406 Auxiliary Charger/Power Supply	An internal battery charger for 7AH to 26 AH	Normal Charge: 27.6 VDC Charging Current: 1.1 A max (0.750 A typical)
ACPS-610 Addressable Charger/Power Supply	An internal battery charger for 12AH to 200AH	Normal Charge: 27.6 VDC +/- 0.24 VDC Charging Current: 2A, 5A, or OFF (Software Selectable)

### Signaling Line Circuit (SLC)

Item	Value
Voltage	24 VDC nominal, 27.6 VDC maximum
Maximum length	12,500 ft. (3810 m) per channel (NFPA Style 4) or 10,000 ft. (3048 m) total loop or circuit length (NFPA Style 6 and 7) <b>Note:</b> Refer to Appendix B.2 “Wire Requirements” for limitations.
Maximum current	400 mA peak, 200 mA average (max short circuit; circuit will shut down until short is fixed)
Maximum resistance	50 ohms (supervised and power-limited)

## Notification Appliance Circuits & Releasing Circuits

Item	Value
Max. wiring voltage drop	2 VDC (Retrofit note: SLCs with old CMX modules are restricted to 1.2 VDC.)
NAC Nominal operating voltage	24 VDC regulated, 1.5 A max.
Special Applications for Releasing Circuits	20.16 - 26.42 VDC
Current for all external devices connected to the control panel's power supply	6.0 A in alarm (3 A continuous) TB10 and all 4 NACs share a maximum of 3.0 A.
Optional ACPS-2406	Total 6 A in alarm (5 A continuous)
Optional ACPS-610	Total 6 A in alarm (1.5 A single output)
Optional APS-6R	Total 6 A in alarm (4 A continuous)
Maximum signaling current/circuit per NAC	2.5 A Note: Some devices have maximum draws less than this; refer to the device's documentation.
End-of-Line Resistors (ELRs)	Control Panel NACs (TB6, TB7, TB8, TB9): 2.2K, 1/2 watt XP6-C, FCM-1 Modules: 47K, 1/2 watt
NOTE: For a list of compatible Notification Appliance Circuits and Releasing Circuits see Notifier Device Compatibility Document 15378.	

## Output Relays

Output relays for Alarm and Trouble are common on TB4; Supervisory and Security are programmable on TB5. See Figure 3.22, "Form-C Relay Connections" on page 38).

Contact ratings: 2.0 A @ 30 VDC (resistive)

## Four-wire Smoke Detector Power

Control Panel terminals TB10 RESET (+) and (–) supply filtered, low-noise power for four-wire smoke detectors. Specifications are:

- Nominal voltage: 24 VDC special applications.
- Maximum rated current: 1.25 A DC
- Maximum ripple voltage: 176 mVrms
- TB10, TB2, and all 4 NACs share a maximum of 3.0 A.

Refer to the *Device Compatibility Document* for compatible 24 VDC detectors.

## Power Output

Control Panel terminals TB10 NONRESET (+) and (–) supply one (1) power-limited circuit available to power external devices, such as notification appliances and annunciators.

- Nominal voltage: 24 VDC regulated, special applications, 1.5 A max.
- Maximum rated current: 1.25 A DC
- Maximum ripple voltage: 176 mVrms
- TB10, TB2, and all 4 NACs share a maximum of 3.0 A.

Refer to the *Device Compatibility Document* for compatible devices and notification appliances.



**NOTE:** The Control Panel provides a total of 7.4 A of power in alarm (4.4 A in standby), shared by all internal circuitry and external provisions (24 V resettable and non-resettable). TB10 and all 4 NACs share a maximum of 3.0 A. For power requirements, refer to the power supply calculation tables in Appendix A.

### Operating Power: AC Branch Circuit

The control panel requires connection to a separate dedicated AC branch circuit. Follow these guidelines when connecting the AC branch circuit:

- Label the branch circuit “Fire Alarm”. This must be a separate dedicated AC fire alarm circuit.
- Connect the branch circuit to the line side of the main power feed of the protected premises.
- Do not power other equipment from the fire alarm branch circuit.
- Run the AC branch circuit wire continuously, without any disconnect devices except for overcurrent protection, from the power source to the fire alarm control panel.
- Overcurrent protection for the AC branch circuit must comply with Article 760 of the National Electrical Codes, as well as local codes.
- Use 12 AWG (3.31 mm<sup>2</sup>) wire with 600 VAC insulation for the AC branch circuit.

Connect the ground terminal (TB1-Earth) to a solid earth ground (a metallic, cold water pipe may be suitable in some installations). This connection is vital to maintaining the control panel’s immunity to unwanted transients generated by lightning and electrostatic discharge.

### Operating Power: Secondary Power Source (Batteries)

The battery charger is current-limited and can recharge sealed lead-acid type batteries. The battery charger shuts off when the control panel is in alarm.

## B.2 Wire Requirements

Each type of circuit within the Fire Alarm Control System requires use of a specific wire type to ensure proper circuit operation. The wire gauge of a particular circuit depends on the length of that circuit and the current traveling through it. Use Table B.1 below to determine the specific wiring requirements for each circuit.

Compliance with the Federal Communications Commission (FCC) and Canadian Department of Communication regulations on electrical energy radiation requires the following: Use twisted-pair shielded wire for any non-SLC-loop wiring entering or exiting the cabinet that is not enclosed in conduit. Use twisted-pair unshielded wiring for SLC-loop wiring.



---

**NOTE:** If running an SLC in conduit with Notification Appliance Circuits, you can reduce problems by exclusively using electronic sounders (such as the SpectrAlert, SpectrAlert Advanced or MA/SS-24 Series) instead of more electronically noisy notification appliances (such as electromechanical bells or horns).

---

Circuit Type	Circuit Function	Wire Requirements	Distance (feet/meters)	Typical Wire Type
SLC (power limited)	Connects to intelligent and addressable modules.	Twisted-unshielded pair, 12 to 18 AWG (3.31 to 0.82 mm <sup>2</sup> ). 50 ohms maximum per length of Style 6 & 7 loops. 50 ohms per branch maximum for Style 4 loop.	12,500 ft. (3,810 m) 9,500 ft. (2,895.6 m) 6,000 ft. (1,828.8 m) 3,700 ft. (1,127.76 m)	12 AWG (3.31 mm <sup>2</sup> ) 14 AWG (2.08 mm <sup>2</sup> ) 16 AWG (1.31 mm <sup>2</sup> ) 18 AWG (0.82 mm <sup>2</sup> )
	or	Untwisted, unshielded wire, in conduit or outside of conduit.	5,000 ft. (304.8 m)  3,700 ft. (1,127.76 m)	12 to 16 AWG (3.31 to 1.31 mm <sup>2</sup> )  18 AWG (0.82 mm <sup>2</sup> )
<b>Note:</b> Maximum total capacitance of all SLC wiring (both between conductors and from any conductor to ground) should not exceed 0.5 microfarads.				
EIA-485 (power limited)	Connects to FDU-80, ACS modules, or TM-4 Transmitter	Twisted-shielded pair with a characteristic impedance of 120 ohms. 18 AWG (0.82 mm <sup>2</sup> ) minimum.	6,000/1829 (max)	16 AWG (1.31 mm <sup>2</sup> )
EIA-232 (power limited)	Connects to Printers, CRT, or PC.	Twisted-shielded pair in conduit. 18 AWG (0.82 mm <sup>2</sup> ) minimum.	20 feet (6.1 m) (without modem)	16 AWG (1.31 mm <sup>2</sup> )
IDC Initiating Device Circuit	FMM-1, FMM-101, FDM-1XP10-M, XP6-MA (power limited)	12-18 AWG (3.31 to 0.82 mm <sup>2</sup> ). Maximum circuit resistance is 20 ohms.		12 to 18 AWG (3.31 to 0.82 mm <sup>2</sup> )
NAC Notification Appliance Circuit	FCM-1*, XP6-C (power limited)	12-18 AWG (3.31 to 0.82 mm <sup>2</sup> ). At alarm current level, no more than a 1.2 V drop at the end of the circuit, or sized to provide the minimum rated operating voltage of the appliances used.	.To meet 1.2 V drop, or sized to provide the minimum rated operating voltage of the appliances used.	12 to 18 AWG (3.31 to 0.82 mm <sup>2</sup> )
Releasing Module	FCM-1-REL	12-18 AWG (3.31 to 0.82 mm <sup>2</sup> ). 5 ohms maximum per circuit for class A or B, or sized to provide the minimum rated operating voltage of the appliances used.	To meet 5 ohms maximum circuit resistance, or sized to provide the minimum rated operating voltage of the appliances used	12 to 18 AWG (3.31 to 0.82 mm <sup>2</sup> )
24 VDC Power Runs (power-limited)	To TM-4 Transmitter, Annunciator and FCM-1 modules	12-18 AWG (3.31 to 0.82 mm <sup>2</sup> ). Size wire so that no more than 1.2 V drop across wire run from supply source to end of any branch.	To meet 1.2 volt drop	12 to 18 AWG (3.31 to 0.82 mm <sup>2</sup> )
CHG-120	External battery charger	12 AWG (3.31 mm <sup>2</sup> ) in conduit	20/6.1 (max)	12 AWG (3.31 mm <sup>2</sup> )

\* FCM-1 cannot be used for synchronized strobe.sounder applications.

**Table B.1 Wire Requirements**



**NOTE:** Lightning arresters required on circuits extending between buildings; 999 meter length maximum to meet UL 60950.

# Appendix C: Canadian Applications

## C.1 Standalone Application

### C.1.1 NFS2-640/E with KDM-R2

If using KDM-R2 as the primary display for NFS2-640/E, an ACS series annunciator must be mounted adjacent to the panel or within NFS2-640/E enclosure.

### C.1.2 NFS2-640/E with NCA-2

Network Control Annunciator (NCA-2) with 640-character, multi-line display complies with ULC requirements when used as the primary display for NFS2-640/E.

## C.2 Local Network Application

To meet ULC requirements, the network's Manual Controls may only be operated from one location at any given time. When panels are networked (using NCM Network Communications Modules), use AKS-1B Key Switch on each panel's Primary Annunciator to enable its functions. NCA-2 may be a Primary Annunciator when AKS-1B is installed. Refer to the *NCA-2 Manual* for more information.

The NCA-2 or Network Control Station (NCS) may be employed as a Display and Control Center. In the event that communication fails between the panels and the Control Center, the panels will continue to function in local/standalone mode.

## C.3 Automatic Alarm Signal Silence

If selecting this feature for a system requiring annunciators, consult the Authority Having Jurisdiction.

## C.4 Annunciator Applications

1. In Canada, the ACM series annunciator modules must be used to annunciate the fire alarm input points/zones only, if no multi-line sequential display is installed.
2. For Canadian applications, the following LED colors must be employed:
  - Red must be used to indicate active alarm inputs.
  - Yellow must be used to indicate supervisory, burglary or trouble signals.
  - Green must be used to indicate the presence of power or an activated output.

## C.5 Releasing Devices

Supervision for shorts is required; use REL devices and type code REL CKT ULC. (With on-board NACs, use REL-2.2K; with FCM-1 modules use REL-47K. Refer to Section 4.6 "Releasing Applications" for details.

## Notes



# Index

## Numerics

24 VDC, *see* Power (DC)

## A

A77-716B, *see* Power Supervision Relay

*Replaced by EOLR-1*

AC, *also see* Power **34, 35**

Acceptance Test **59**

ACM-8R

Labeling Requirements **40**

Agent Release-Abort Station **57**

Alarm Relays, *see* Form-C Relays **38**

## B

Backup-Alarm Switches **38**

Basic Equipment Packages **12**

Batteries, *also see* Power: DC

Battery Calculations **61, 62, 63, 65, 66**

Battery Checks and Maintenance **60**

Battery Specifications **67**

Connections **35**

Battery Plate **22**

Battery plate **25**

## C

Cabinets **16**

Mounting **20**

Canadian Applications **26, 71**

Central Receiving Unit, *also see* UDACT Manual **51**

Chassis **29**

Circuit Board, *see* CPU

Compatible Equipment **17, 18**

Components **14, 15**

Control Panel Circuit Board, *see* CPU

CPS-24/E, *see* Power Supply

CPU

CPU-640 (120V operation) **12**

CPU-640E (240V operation) **12**

Drawing **13, 14, 15**

Installation Steps **25**

Overview **13**

CRTs **45**

CRT/PRN Combination **45**

CRT-2 Configuration **43**

CRT-2 Function Keys and Parameters **44**

Installation **40–45**

## D

DC, *also see* Power **34, 35**

DVC **32**

## E

Electrical Connections **33**

Electrical Specifications **67**

EOLR-1 *see* Power Supervision Relay

External Power Supervision **47**

## F

FCM-1 **55**

FCM-1-REL **56**

Fire/Security Applications **50–52**

FMM-1 **51**

Form-C Relays **38, 68**

Four-wire Smoke Detector  
Specifications **68**

## I

Installation

Checklist **20**

Preparation **19**

## J

Jumper Locations **14, 15**

## K

KDM-R2

Installation Steps **25**

Keltron, *also see* Printers **42**

## L

LDM-R32

Non-Power-Limited Circuits **40**

LED Locations **15**

Lockout **59**

Loop Expander Module

Installation Steps **30**

## M

Main Power Supply, *see* Power Supply

Maintenance **59**

Microcontroller Failure **38**

Mounting

LEM **31**

Multiple Detector Operation **45**

## N

NACs (Notification Appliance Circuits)

- Backup Option **38**
  - NAC Connections **37**
  - Releasing Applications **37, 38, 52, 53**
  - Specifications **68**
  - NBG-12LRA **57**
  - NCA-2, *also see* Primary Display **12**
  - Networking **31**
  - NFPA Applications
    - NFPA 72 Central or Remote Station Fire Alarm System **48**
  - NFPA Applications (Overview) **47**
  - Non-Power-Limited Circuits
    - UL Wiring Requirements **39, 40**
  - Notification Appliance Circuits, *see* NACs
- O**
- Operating Power **69**
  - Operational Checks **59**
  - Option Boards
    - Installation Steps **27**
  - Output Relays
    - Connections **38, 68**
    - Specifications **68**
- P**
- Periodic Testing **59**
  - Power
    - AC Power Checklist **35**
    - AC Power Connections **34, 35**
    - AC Specifications **67**
    - DC Power Connections **34, 35, 36**
    - Installation Steps **33**
    - Power Specifications **33, 68**
  - Power Supervision Relay **55**
  - Power Supply Calculations **61, 62, 63, 65, 66**
  - Power-Limited Wiring Requirements **39**
  - Primary Display **12, 26**
  - primary display **25**
  - Printers **45**
    - Installation **40–45**
    - Keltron Printer Connections **42**
    - PRN Series Connections **41**
    - PRN Settings **41**
    - PRN/CRT Combination **45**
  - Proprietary Security Alarm Applications Wiring **51**
  - Protected Premises Unit **48**
- R**
- Related Documentation **8**
  - Relays, *see* Form-C Relays **38**
  - Releasing Circuits
    - Connections **37**
    - Releasing Applications **52–58**
    - Releasing Applications, Canada **71**
    - Specifications **68**
  - Releasing Device
    - Connections **53**
    - FCM-1 Connections **55**
    - FCM-1-REL Connections **56**
- S**
- Security Relays, *see* Form-C Relays **38**
  - Security Tamper Switch **50, 51**
  - Service **59**
  - SLC **30**
  - SLC, *also see* SLC Wiring Manual **45**
    - Specifications **67**
  - Specifications **67, 68**
  - Stacker-Connector **31**
  - Stand-Off Lengths **23**
  - STS-1, *also see* Security Tamper Switch **51**
  - Supervisory and Security Contacts
    - Configuring as Alarm Contacts **38**
  - Supervisory Relays, *see* Form-C Relays **38**
  - Supplemental Documentation **8**
  - Switches
    - Backup-Alarm **38**
    - Switch Locations **14, 15**
  - System
    - Description of Features **11**
    - Limitations **12**
    - Options **12**
  - System Current Draws **61, 62, 63, 65, 66**
- T**
- Terminal Block Locations **14, 15**
  - Testing **59**
  - TM-4, *also see* *TM-4 Installation Document* **30**
  - Trouble Relays, *see* Form-C Relays **38**
- U**
- UL Non-Power-Limited Wiring Requirements **39**
  - UL Requirements **39**
- V**
- VeriFire **46**
- W**
- Wiring
    - Proprietary Security Alarm Applications **51**
    - Wire Requirements **69**

## Limited Warranty

**Honeywell International Inc.** warrants products manufactured by it to be free from defects in materials and workmanship for eighteen (18) months from the date of manufacture, under normal use and service. Products are date stamped at time of manufacture. The sole and exclusive obligation of **Honeywell International Inc.** is to repair or replace, at its option, free of charge for parts and labor, any part that is defective in materials or workmanship under normal use and service. All returns for credit are subject to inspection and testing at the factory before actual determination is made to allow credit. **Honeywell International Inc.** does not warrant products not manufactured by it, but assigns to the purchaser any warranty extended by the manufacturer of such products. This warranty is void if the product is altered or repaired by anyone other than **Honeywell International Inc.** or as expressly authorized by **Honeywell International Inc.** in writing, or is serviced by anyone other than **Honeywell International Inc.** or its authorized distributors. This warranty is also void if there is a failure to maintain the products and systems in which they operate in a proper and workable manner. In case of defect, secure a Return Material Authorization form from our Return Authorization Department.

This writing constitutes the only warranty made by **Honeywell International Inc.**, with respect to its products. **Honeywell International Inc.**, does not represent that its products will prevent any loss by fire or otherwise, or that its products will in all cases provide the protection for which they are installed or intended. Buyer acknowledges that **Honeywell International Inc.**, is not an insurer and assumes no risk for loss or damages or the cost of any inconvenience, transportation damage, misuse, abuse, accident or similar incident.

**HONEYWELL INTERNATIONAL INC.** GIVES NO WARRANTY, EXPRESS OR IMPLIED, OF MERCHANTABILITY, FITNESS FOR ANY PARTICULAR PURPOSE, OR OTHERWISE WHICH EXTENDS BEYOND THE DESCRIPTION ON THE FACE HEREOF. UNDER NO CIRCUMSTANCES SHALL **HONEYWELL INTERNATIONAL INC.** BE LIABLE FOR ANY LOSS OF OR DAMAGE TO PROPERTY, DIRECT, INCIDENTAL OR CONSEQUENTIAL, ARISING OUT OF THE USE OF, OR INABILITY TO USE **HONEYWELL INTERNATIONAL INC.'S** PRODUCTS. FURTHERMORE, **HONEYWELL INTERNATIONAL INC.** SHALL NOT BE LIABLE FOR ANY PERSONAL INJURY OR DEATH WHICH MAY ARISE IN THE COURSE OF, OR AS A RESULT OF, PERSONAL, COMMERCIAL OR INDUSTRIAL USE OF ITS PRODUCTS.

This warranty replaces all previous warranties and is the only warranty made by **Honeywell International Inc.** No increase or alteration, written or verbal, of the obligation of this warranty is authorized.

Warn-HL-05-2007.fm



---

World Headquarters  
12 Clintonville Road  
Northford, CT 06472-1610 USA  
203-484-7161  
fax 203-484-7118

[www.notifier.com](http://www.notifier.com)

**ISO 9001**  
**CERTIFIED**  
ENGINEERING & MANUFACTURING  
QUALITY SYSTEMS

PREACTION-PAC  
with NOTIFIER NFS2-640 RELEASING CONTROL PANEL  
INSTALLATION, OPERATION, AND MAINTENANCE MANUAL  
P/N 10-500001-00B  
VERSION 1.1 – JULY 2011

# SECTION

# 4.2

Notifier Manual 52743

NFS2-640 Control Panel  
Operation



---

**Fire Alarm Control Panel**  
**NFS2-640/E**  
**Operations Manual**

Document 52743	Rev: <b>E</b>
1/18/2010	
P/N 52743:E	ECN 10-249



# Fire Alarm System Limitations

*While a fire alarm system may lower insurance rates, it is not a substitute for fire insurance!*

**An automatic fire alarm system**—typically made up of smoke detectors, heat detectors, manual pull stations, audible warning devices, and a fire alarm control panel with remote notification capability—can provide early warning of a developing fire. Such a system, however, does not assure protection against property damage or loss of life resulting from a fire.

The Manufacturer recommends that smoke and/or heat detectors be located throughout a protected premise following the recommendations of the current edition of the National Fire Protection Association Standard 72 (NFPA 72), manufacturer's recommendations, State and local codes, and the recommendations contained in the Guides for Proper Use of System Smoke Detectors, which are made available at no charge to all installing dealers. These documents can be found at <http://www.systemsensor.com/html/applicat.html>. A study by the Federal Emergency Management Agency (an agency of the United States government) indicated that smoke detectors may not go off in as many as 35% of all fires. While fire alarm systems are designed to provide early warning against fire, they do not guarantee warning or protection against fire. A fire alarm system may not provide timely or adequate warning, or simply may not function, for a variety of reasons:

**Smoke detectors** may not sense fire where smoke cannot reach the detectors such as in chimneys, in or behind walls, on roofs, or on the other side of closed doors. Smoke detectors also may not sense a fire on another level or floor of a building. A second-floor detector, for example, may not sense a first-floor or basement fire.

**Particles of combustion or "smoke"** from a developing fire may not reach the sensing chambers of smoke detectors because:

- Barriers such as closed or partially closed doors, walls, or chimneys may inhibit particle or smoke flow.
- Smoke particles may become "cold," stratify, and not reach the ceiling or upper walls where detectors are located.
- Smoke particles may be blown away from detectors by air outlets.
- Smoke particles may be drawn into air returns before reaching the detector.

The amount of "smoke" present may be insufficient to alarm smoke detectors. Smoke detectors are designed to alarm at various levels of smoke density. If such density levels are not created by a developing fire at the location of detectors, the detectors will not go into alarm.

Smoke detectors, even when working properly, have sensing limitations. Detectors that have photoelectronic sensing chambers tend to detect smoldering fires better than flaming fires, which have little visible smoke. Detectors that have ionizing-type sensing chambers tend to detect fast-flaming fires better than smoldering fires. Because fires develop in different ways and are often unpredictable in their growth, neither type of detector is necessarily best and a given type of detector may not provide adequate warning of a fire.

Smoke detectors cannot be expected to provide adequate warning of fires caused by arson, children playing with matches (especially in bedrooms), smoking in bed, and violent explosions (caused by escaping gas, improper storage of flammable materials, etc.).

**Heat detectors** do not sense particles of combustion and alarm only when heat on their sensors increases at a predetermined rate or reaches a predetermined level. Rate-of-rise heat detectors may be subject to reduced sensitivity over time. For this reason, the rate-of-rise feature of each detector should be tested at least once per year by a qualified fire protection specialist. Heat detectors are designed to protect property, not life.

**IMPORTANT! Smoke detectors** must be installed in the same room as the control panel and in rooms used by the system for the connection of alarm transmission wiring, communications, signaling, and/or power. If detectors are not so located, a developing fire may damage the alarm system, crippling its ability to report a fire.

**Audible warning devices** such as bells may not alert people if these devices are located on the other side of closed or partly open doors or are located on another floor of a building. Any warning device may fail to alert people with a disability or those who have recently consumed drugs, alcohol or medication. Please note that:

- Strobes can, under certain circumstances, cause seizures in people with conditions such as epilepsy.
- Studies have shown that certain people, even when they hear a fire alarm signal, do not respond or comprehend the meaning of the signal. It is the property owner's responsibility to conduct fire drills and other training exercise to make people aware of fire alarm signals and instruct them on the proper reaction to alarm signals.
- In rare instances, the sounding of a warning device can cause temporary or permanent hearing loss.

**A fire alarm system** will not operate without any electrical power. If AC power fails, the system will operate from standby batteries only for a specified time and only if the batteries have been properly maintained and replaced regularly.

**Equipment used in the system** may not be technically compatible with the control panel. It is essential to use only equipment listed for service with your control panel.

**Telephone lines** needed to transmit alarm signals from a premise to a central monitoring station may be out of service or temporarily disabled. For added protection against telephone line failure, backup radio transmission systems are recommended.

**The most common cause** of fire alarm malfunction is inadequate maintenance. To keep the entire fire alarm system in excellent working order, ongoing maintenance is required per the manufacturer's recommendations, and UL and NFPA standards. At a minimum, the requirements of NFPA 72 shall be followed. Environments with large amounts of dust, dirt or high air velocity require more frequent maintenance. A maintenance agreement should be arranged through the local manufacturer's representative. Maintenance should be scheduled monthly or as required by National and/or local fire codes and should be performed by authorized professional fire alarm installers only. Adequate written records of all inspections should be kept.

Limit-C1-2-2007

# Installation Precautions

*Adherence to the following will aid in problem-free installation with long-term reliability:*

**WARNING - Several different sources of power can be connected to the fire alarm control panel.** Disconnect all sources of power before servicing. Control unit and associated equipment may be damaged by removing and/or inserting cards, modules, or interconnecting cables while the unit is energized. Do not attempt to install, service, or operate this unit until manuals are read and understood.

**CAUTION - System Re-acceptance Test after Software Changes:** To ensure proper system operation, this product must be tested in accordance with NFPA 72 after any programming operation or change in site-specific software. Re-acceptance testing is required after any change, addition or deletion of system components, or after any modification, repair or adjustment to system hardware or wiring. All components, circuits, system operations, or software functions known to be affected by a change must be 100% tested. In addition, to ensure that other operations are not inadvertently affected, at least 10% of initiating devices that are not directly affected by the change, up to a maximum of 50 devices, must also be tested and proper system operation verified.

**This system** meets NFPA requirements for operation at 0-49° C/32-120° F and at a relative humidity 93% ± 2% RH (non-condensing) at 32°C ± 2°C (90°F ± 3°F). However, the useful life of the system's standby batteries and the electronic components may be adversely affected by extreme temperature ranges and humidity. Therefore, it is recommended that this system and its peripherals be installed in an environment with a normal room temperature of 15-27° C/60-80° F.

**Verify that wire sizes are adequate** for all initiating and indicating device loops. Most devices cannot tolerate more than a 10% I.R. drop from the specified device voltage.

**Like all solid state electronic devices,** this system may operate erratically or can be damaged when subjected to lightning induced transients. Although no system is completely immune from lightning transients and interference, proper grounding will reduce susceptibility. Overhead or outside aerial wiring is not recommended, due to an increased susceptibility to nearby lightning strikes. Consult with the Technical Services Department if any problems are anticipated or encountered.

**Disconnect AC power and batteries** prior to removing or inserting circuit boards. Failure to do so can damage circuits.

**Remove all electronic assemblies** prior to any drilling, filing, reaming, or punching of the enclosure. When possible, make all cable entries from the sides or rear. Before making modifications, verify that they will not interfere with battery, transformer, or printed circuit board location.

**Do not tighten screw terminals** more than 9 in-lbs. Overtightening may damage threads, resulting in reduced terminal contact pressure and difficulty with screw terminal removal.

**This system contains static-sensitive components.** Always ground yourself with a proper wrist strap before handling any circuits so that static charges are removed from the body. Use static suppressive packaging to protect electronic assemblies removed from the unit.

**Follow the instructions** in the installation, operating, and programming manuals. These instructions must be followed to avoid damage to the control panel and associated equipment. FACP operation and reliability depend upon proper installation.

Precau-D1-9-2005

## FCC Warning

**WARNING:** This equipment generates, uses, and can radiate radio frequency energy and if not installed and used in accordance with the instruction manual may cause interference to radio communications. It has been tested and found to comply with the limits for class A computing devices pursuant to Subpart B of Part 15 of FCC Rules, which is designed to provide reasonable protection against such interference when devices are operated in a commercial environment. Operation of this equipment in a residential area is likely to cause interference, in which case the user will be required to correct the interference at his or her own expense.

## Canadian Requirements

This digital apparatus does not exceed the Class A limits for radiation noise emissions from digital apparatus set out in the Radio Interference Regulations of the Canadian Department of Communications.

Le present appareil numerique n'emet pas de bruits radioelectriques depassant les limites applicables aux appareils numeriques de la classe A prescrites dans le Reglement sur le brouillage radioelectrique edicte par le ministere des Communications du Canada.

HARSH™, NIS™, Notifier Integrated Systems™, and NOTI-FIRE-NET™ are all trademarks; and Acclimate® Plus, FlashScan®, NION®, NOTIFIER®, ONYX®, ONYXWorks®, UniNet®, VeriFire®, and VIEW® are all registered trademarks of Honeywell International Inc. Echelon® is a registered trademark and LonWorks™ is a trademark of Echelon Corporation. ARCNET® is a registered trademark of Datapoint Corporation. Microsoft® and Windows® are registered trademarks of the Microsoft Corporation.

©2010 by Honeywell International Inc. All rights reserved. Unauthorized use of this document is strictly prohibited.

## Software Downloads

In order to supply the latest features and functionality in fire alarm and life safety technology to our customers, we make frequent upgrades to the embedded software in our products. To ensure that you are installing and programming the latest features, we strongly recommend that you download the most current version of software for each product prior to commissioning any system. Contact Technical Support with any questions about software and the appropriate version for a specific application.

## Documentation Feedback

Your feedback helps us keep our documentation up-to-date and accurate. If you have any comments or suggestions about our online Help or printed manuals, you can email us.

Please include the following information:

- Product name and version number (if applicable)
- Printed manual or online Help
- Topic Title (for online Help)
- Page number (for printed manual)
- Brief description of content you think should be improved or corrected
- Your suggestion for how to correct/improve documentation

Send email messages to:

**FireSystems.TechPubs@honeywell.com**

Please note this email address is for documentation feedback only. If you have any technical issues, please contact Technical Services.

# Table of Contents

<b>Section 1: General Information.....</b>	<b>9</b>
1.1: UL 864 Compliance.....	9
1.2: About This Manual.....	9
1.2.1: Cautions and Warnings.....	9
1.2.2: Typographic Conventions.....	9
1.2.3: Supplemental Information.....	10
1.2.4: Shortcuts to Operating Functions.....	11
1.3: Introduction to the Control Panel.....	11
<b>Section 2: Use of the Controls.....</b>	<b>13</b>
2.1: Introduction.....	13
2.2: System Status Indicator LEDs.....	13
2.3: Control Keys.....	14
2.3.1: Acknowledge/Scroll Display.....	14
2.3.2: Signal Silence.....	15
2.3.3: System Reset.....	15
2.3.4: Drill.....	15
2.3.5: Lamp Test.....	17
2.4: Programming Keypad.....	17
<b>Section 3: Operation of the Control Panel.....</b>	<b>19</b>
3.1: Overview.....	19
3.2: Normal Mode of Operation.....	19
3.3: Fire Alarm Mode of Operation.....	20
3.3.1: How the Control Panel Indicates a Fire Alarm.....	20
3.3.2: How to Respond to a Fire Alarm.....	20
3.3.3: Interpreting Fire Alarm Type Codes.....	21
3.4: System Trouble Mode of Operation.....	22
3.4.1: How the Control Panel Indicates a System Trouble.....	22
3.4.2: How to Respond to a System Trouble.....	23
3.5: Security Alarm Mode of Operation.....	24
3.5.1: How the Control Panel Indicates a Security Alarm.....	24
3.5.2: How to Respond to a Security Alarm.....	24
3.5.3: Interpreting Security Type Codes.....	25
3.6: Active Supervisory Signal Mode of Operation.....	25
3.6.1: How the Control Panel Indicates an Active Supervisory.....	25
3.6.2: How to Respond to an Active Supervisory.....	26
3.6.3: How to Interpret Supervisory Type Codes.....	26
3.7: Pre-Alarm Warning Mode of Operation.....	27
3.7.1: How the Control Panel Indicates a Pre-Alarm Warning.....	27
3.7.2: How to Respond to a Pre-Alarm Warning.....	27
3.8: Disabled Points Mode of Operation.....	28
3.9: Non-Alarm Mode of Operation.....	29
3.9.1: Purpose of Non-Alarm Points.....	29
3.9.2: How the Control Panel Indicates an Active Fire Control.....	29
3.9.3: How the Control Panel Indicates an Active Non-Fire Point.....	30
3.10: Active Trouble Monitor Mode of Operation.....	30
3.10.1: How the Control Panel Indicates an Active Trouble Monitor.....	30
3.10.2: How to Respond to an Active Trouble Monitor.....	30
3.11: Output Circuit Trouble Mode of Operation.....	31
3.11.1: Overview.....	31
3.11.2: How the Control Panel Indicates a NAC Trouble.....	32
3.11.3: How the Control Panel Indicates a Control/Relay Trouble.....	32
3.11.4: How to Respond to a NAC or Control/Relay Trouble.....	32
3.12: Operation of Special System Timers.....	33

3.12.1: What are System Timers? .....	33
3.12.2: How to View System Timer Selections .....	33
3.12.3: How System Timers Work .....	33
3.13: Waterflow Circuit Operation .....	34
3.14: Style 6 and Style 7 Operation .....	34
<b>Section 4: Read Status Operation .....</b>	<b>35</b>
4.1: Introduction .....	35
4.2: What is Read Status? .....	35
4.2.1: Quick Reference Key Sequences .....	35
4.3: Entering Read Status .....	35
4.4: Viewing and Printing a Read Status .....	36
4.4.1: How to View Read Status of Devices, Zones, & System Settings .....	36
4.4.2: How to View Read Status for Event and Alarm History .....	45
4.4.3: How to Print Points, Event and Alarm History .....	46
4.4.4: How to View and Print Hidden Event and Alarm History .....	48
<b>Appendix A: Special Zone Operation .....</b>	<b>51</b>
A.1: Overview .....	51
A.2: Releasing Zones (R0-R9) .....	51
A.2.1: Purpose of Releasing Zones .....	51
A.2.2: How to View Releasing Zone Selections .....	52
A.2.3: How Releasing Zones Operate .....	52
A.3: Time, Date, and Holiday Functions .....	54
A.3.1: Overview .....	54
A.3.2: How to View Time Control Selections .....	54
A.3.3: How to View Holiday Function Selections .....	55
A.3.4: How Time Control and Holiday Functions Work .....	55
A.4: NAC Coding .....	56
A.4.1: Overview of Coding .....	56
A.4.2: How to View Coding (F8) Selections .....	56
A.4.3: How to Respond to an Alarm with Coding .....	57
A.5: Presignal and Positive Alarm Sequence (PAS) Operation .....	57
A.5.1: Overview .....	57
A.5.2: What is Presignal and PAS? .....	57
A.5.3: How to View Presignal and PAS Selections .....	58
A.5.4: How to Respond to an Alarm with Presignal Delay Timer (no PAS) .....	58
A.5.5: How to Respond to an Alarm with Presignal Delay Timer (PAS selected) .....	59
<b>Appendix B: Intelligent Detector Functions .....</b>	<b>61</b>
<b>Appendix C: Remote Terminal Access .....</b>	<b>63</b>
C.1: General Description .....	63
C.2: Operating Modes .....	63
C.2.1: Local Terminal Mode (LocT) .....	63
C.2.2: Local Monitor Mode (LocM) .....	64
C.2.3: Remote Terminal Mode (RemT) .....	64
C.3: Using the CRT-2 for Read Status .....	65
C.3.1: Overview .....	65
C.3.2: Accessing Read Status Options .....	65
C.3.3: Read Point .....	66
C.3.4: Display Devices in Alarm or Trouble .....	66
C.3.5: Display All Programmed Points .....	67
C.3.6: Step-through History .....	67
C.3.7: View All History .....	67
C.3.8: Step-through Alarm History .....	67
C.3.9: View All Alarm History .....	67
C.4: Using the CRT-2 for Alter Status .....	68

---

C.4.1: Overview .....	68
C.4.2: Accessing Alter Status Options .....	68
C.4.3: Enable or Disable Detectors, Modules or Zones .....	69
C.4.4: Change Alarm and Pre-Alarm Levels.....	69
C.4.5: Clear Verification Counter.....	70
C.4.6: Clear the Entire History Buffer.....	70
C.4.7: Set the Pre-Alarm for Alert or Action.....	70
<b>Appendix D: Point and System Troubles Lists .....</b>	<b>71</b>
D.1: Point (Device) Troubles .....	71
D.2: System Troubles.....	72
<b>Index.....</b>	<b>77</b>





# Section 1: General Information

## 1.1 UL 864 Compliance

This product has been certified to comply with the requirements in the Standard for Control Units and Accessories for Fire Alarm Systems, UL 864 9th Edition.

## 1.2 About This Manual

### 1.2.1 Cautions and Warnings

This manual contains cautions and warnings to alert the reader as follows:



---

**CAUTION:**

Information about procedures that could cause programming errors, runtime errors, or equipment damage.

---



---


**WARNING:**

Indicates information about procedures that could cause irreversible damage to the control panel, irreversible loss of programming data or personal injury.

---

### 1.2.2 Typographic Conventions

This manual uses the following typographic conventions as listed in below:

When you see	Specifies	Example
text in small caps	the text as it appears in the LCD display or on the control panel	MARCH TIME is a selection that appears in the LCD display; or Press the ENTER key
text in quotes	a reference to a section or a LCD menu screen	"Read Status"; specifies the Read Status section or menu screen
bold text	In body text, a number or character that you enter	Press <b>1</b> ; means to press the number "1" on the keypad
italic text	a specific document	<i>NFS2-640 Installation Manual</i>
a graphic of the key	In a graphic, a key as it appears on the control panel	Press  means to press the Escape key

**Table 1.1 Typographic Conventions in this Manual**



---

**NOTE:** In this manual, the term NFS2-640 is used to refer to the NFS2-640 and NFS2-640E unless otherwise noted.

---

## 1.2.3 Supplemental Information

The table below provides a list of documents referenced in this manual, as well as documents for selected other compatible devices. The document series chart (DOC-NOT) provides the current document revision. A copy of this document is included in every shipment.

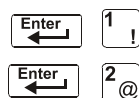
<b>Compatible Conventional Devices (Non-addressable)</b>	<b>Document Number</b>
Device Compatibility Document	15378
<b>Fire Alarm Control Panel (FACP) and Main Power Supply Installation</b>	<b>Document Number</b>
NFS2-640 Installation, Operations, and Programming Manuals	52741, 52742, 52743
DVC and DAA Digital Audio Series Manual	52411
DAA Digital Audio Amplifier Product Installation Document	52410
SLC Wiring Manual	51253
Note: For individual SLC Devices, refer to the <i>SLC Wiring Manual</i>	
<b>Off-line Programming Utility</b>	<b>Document Number</b>
VeriFire® Tools CD help file	VERIFIRE-TCD
Veri•Fire Medium Systems Help File	VERIFIRE-CD
<b>Cabinets &amp; Chassis</b>	<b>Document Number</b>
CAB-3/CAB-4 Series Cabinet Installation Document	15330
Battery/Peripherals Enclosure Installation Document	50295
<b>Power Supplies, Auxiliary Power Supplies &amp; Battery Chargers</b>	<b>Document Number</b>
ACPS-610/E Instruction Manual	53018
ACPS-2406 Installation Manual	51304
APS-6R Instruction Manual	50702
APS2-6R Instruction Manual	53232
CHG-120 Battery Charger Manual	50641
FCPS-24 Field Charger/Power Supply Manual	50059
FCPS-24S6/8 Field Charger/Power Supply Manual (Sync)	51977
<b>Networking</b>	<b>Document Number</b>
Noti•Fire•Net Manual, Network Version 5.0 & Higher	51584
High-Speed Noti•Fire•Net Manual	54013
NCM-W/F Installation Document	51533
HS-NCM High-Speed NCM Document	54014
NCS Network Control Station Manual, Network Version 5.0 & Higher	51658
Onyxworks Workstation	52305, 52306, 52307
<b>System Components</b>	<b>Document Number</b>
Annunciator Control System Manual	15842
Annunciator Fixed Module Manual	15048
AFM-16A Annunciator Fixed Module Manual	15207
ACM-8R Annunciator Control Module Manual	15342
FDU-80 Remote Annunciator Manual	51264
LDM Series Lamp Driver Annunciator Manual	15885
NCA-2 Network Control Annunciator Manual	52482
SCS Smoke Control Manual (Smoke and HVAC Control Station)	15712
RPT-485W/RPT-485WF EIA-485 Annunciator Loop Repeater Manual	15640
DPI-232 Direct Panel Interface Manual	51499

**Table 1.2 Supplemental Documentation (1 of 2)**

TM-4 Installation Document (Reverse Polarity Transmitter)	51490
UDACT Manual (Universal Digital Alarm Communicator/Transmitter)	50050
ACT-2 Installation Document	51118
FireVoice 25/50 & FireVoice 25/50ZS Manual	52290
RM-1 Series Remote Microphone Installation Document	51138
RA400Z Remote LED Annunciator Installation Document	156-508
XP10-M Installation Document	156-1803
XP6-C Installation Document	156-1805
XP6-MA Installation Document	156-1806
XP6-R Installation Document	156-1804
XPIQ Audio Transponder Manual	51013
LCD2-80	53242

**Table 1.2 Supplemental Documentation (2 of 2)**

## 1.2.4 Shortcuts to Operating Functions



To the left of each program function, you'll find a keypad shortcut, which contains a series of keypad entries required to access the program function. All shortcuts start with the control panel in normal operation.

For example, the keypad shortcut to the left, shows how to enter the Read Status function with the control panel in normal operation, as well as how to exit the function.

## 1.3 Introduction to the Control Panel

The NFS2-640 is a modular, intelligent Fire Alarm Control Panel (FACP) with features suitable for most applications. Following is a list of operating features available.

- Alarm Verification selection, to reduce unwanted alarms, for intelligent detector points
- Positive Alarm Sequence (PAS) and Presignal per NFPA 72
- Silence Inhibit timer and Auto Silence timer for Notification Appliance Circuits (NACs)
- March time/temporal code for Notification Appliance Circuits (NACs)
- Programmable Signal Silence, System Reset, and Alarm Activate functions through monitor modules
- Automatic time-of-day and day-of-week control functions, with holiday option
- Intelligent Sensing with nine field-adjustable Pre-Alarm levels with programmable Control-By-Event (CBE)
- Operate automatic smoke or heat detector sounder base on action Pre-Alarm level, with general evacuation on alarm level
- Security alarm point option with separate audible signal code
- Centralized voice paging and audible alarm signaling options
- Programmable Control-By-Event control of outputs from individual alarm or supervisory addressable devices
- Networks with other FACPs and equipment for large applications.



# Section 2: Use of the Controls

## 2.1 Introduction

Listing of the controls and indicators and where to find information on their use:

Operating Components	Covered in
Twelve System Status Indicator LEDs	“System Status Indicator LEDs” on page 13
Five Control Keys	“Control Keys” on page 14
Programming Keypad	“Programming Keypad” on page 17

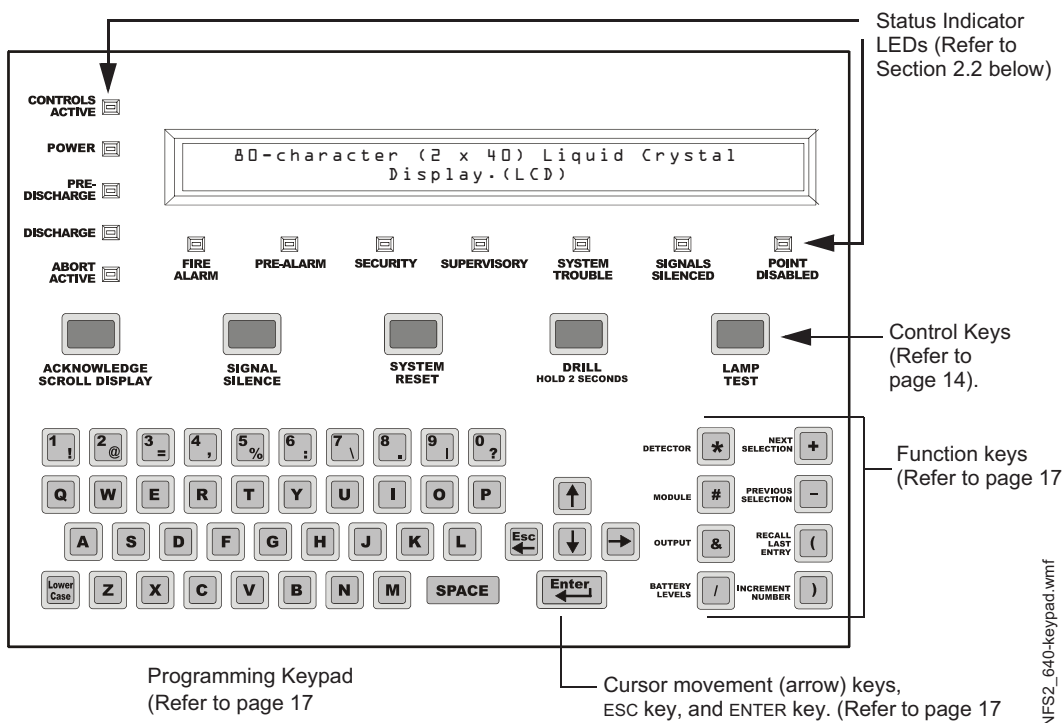


Figure 2.1 NFS2-640 Control Panel Keys and Indicators

## 2.2 System Status Indicator LEDs

The control panel contains 12 labeled LEDs described in Table 2.1.

Indicator	Color	When Active	To Turn Off
CONTROLS ACTIVE	Green	Lights when the panel assumes control of local operation as primary display.	Turns off automatically when another panel assumes control of local operation.
POWER	Green	Lights when the proper primary AC power is applied. Remains lit while power is applied.	Always lit with AC power applied.

Table 2.1 Descriptions of System Status Indicator LEDs (1 of 2)



Indicator	Color	When Active	To Turn Off
PRE-DISCHARGE	Red	Lights when any of the releasing zones have been activated, but have not yet discharged a releasing agent.	Turns off automatically when no releasing zones are in the pre-discharge state.
DISCHARGE	Red	Lights when any of the releasing zones are active and in the process of discharging a releasing agent.	Turns off automatically when no releasing zones are discharging a releasing agent.
ABORT ACTIVE	Yellow	Lights when an abort switch has been activated.*	Turns off automatically when an abort switch has been pressed and its timer is still counting down.
FIRE ALARM	Red	Flashes when a non-acknowledged fire alarm exists. Lights steadily after you acknowledge the fire alarm.	Clear the alarm condition and reset the system.
PRE-ALARM	Red	Flashes when a non-acknowledged fire Pre-Alarm exists. Lights steadily after you acknowledge the Pre-Alarm.	Clear the pre-alarm condition. (An Action Pre-Alarm requires a system reset.)
SECURITY	Blue	Flashes when a non-acknowledged Security alarm exists. Lights steadily after you acknowledge the alarm.	Clear the Security alarm condition and reset the system.
SUPERVISORY	Yellow	Flashes when a non-acknowledged Supervisory condition exists. Lights steadily after you acknowledge the event.	Clear the condition (Supervisory inputs require a system reset if they are latching. Refer to Table 3.3 page 26 for latching information.).
SYSTEM TROUBLE	Yellow	Flashes when a non-acknowledged system trouble exists. Lights steadily after you acknowledge the trouble.	Clear the trouble condition.
SIGNALS SILENCED	Yellow	Lights steadily after a fire alarm condition occurs and after you press SIGNAL SILENCE to silence all outputs. Flashes to indicate that some silenceable outputs are on and some are off.	Press SYSTEM RESET. DRILL will also turn off the LED.
POINT DISABLED	Yellow	Lights when one or more system devices are disabled.	Enable the device or remove the disabled device from the system program.

**Table 2.1 Descriptions of System Status Indicator LEDs (2 of 2)**

- \* Activation of a Manual Release Switch will override Predischarge Delay and override an active Abort Release Switch, resulting in an immediate agent release.

## 2.3 Control Keys

The control panel provides five Control Keys as described below:

### 2.3.1 Acknowledge/Scroll Display

Use the ACKNOWLEDGE/SCROLL DISPLAY key to respond to new alarm or trouble signals. When pressed, the control panel does the following:

- Silences the panel sounder
- Changes all active LED indicators from flashing to steady
- Sends an Acknowledge message to the History buffer and installed printers, CRT-2 terminals, and FDU-80 annunciators
- Sends a signal to silence the sounders on the FDU-80 and ACS annunciators

You can also press this key to display multiple alarms or troubles. If more than one alarm or trouble exists, the control panel displays the next alarm or trouble for 3 seconds (or until you press the ACKNOWLEDGE/SCROLL DISPLAY key), then displays the next alarm or trouble.




---

**NOTE:** If Local Control is set to “0” (No Control), the FACP will not respond to ACKNOWLEDGE, and the piezo will not sound.

---

### 2.3.2 Signal Silence

Use the SIGNAL SILENCE key to silence the panel sounder and turn off all audio and visual devices connected to Notification Appliance Circuits. When pressed, the control panel does the following:

- Turns off the panel sounder
- Turns off all silenceable output circuits
- Lights the SIGNALS SILENCED LED
- Sends a SIGNALS SILENCED message to the History buffer and installed printers, CRT-2 terminals, and FDU-80 annunciators

#### Partial Signal Silence

When some active outputs are silenced and others remain constant, the SIGNALS SILENCED LED will flash.




---

**NOTE:** If Local Control is set to “0” (No Control) or “2” (Partial Control), the FACP will not respond to SIGNAL SILENCE.

---

### 2.3.3 System Reset

Use the SYSTEM RESET key to reset the control panel. When pressed, the control panel does the following:

- Clears ALL active inputs
- Interrupts resettable power
- Sends a “System Reset” message to the History buffer, and installed printers, CRT-2 terminals, and FDU-80 annunciators
- Decouples from Noti•Fire•Net, if connected, for 60 seconds to allow Cooperative Control By Event (CCBE) to clear.

If any alarm or trouble exists after you press the SYSTEM RESET key, all NACs, control outputs, and panel audio and visual indicators will reactivate.




---

**NOTE:** Trouble conditions will not clear and re-report upon reset.

---




---

**NOTE:** If Local Control is set to “0” (No Control), the FACP will not respond to SYSTEM RESET.

---

### 2.3.4 Drill

Use the DRILL key to manually activate all silenceable outputs and Notification Appliance Circuits. To prevent accidental activation, you must press the DRILL key for 2 seconds. When pressed, the control panel does the following:

- Turns on all silenceable NACs

- Turns off the SIGNALS SILENCED LED
- Sends a Manual Evacuate message to the History buffer and installed printers, CRT-2 terminals, and FDU-80 annunciators



---

**NOTE:** If Local Control is set to “0” (No Control) or “2” (Partial Control), the FACP will not respond to DRILL.

---

### 2.3.5 Lamp Test

Use the LAMP TEST key to test the control panel LEDs and the panel sounder. When pressed and held, the control panel does the following:

- Lights all control panel LEDs
- Turns on the panel sounder
- Lights all segments of the LCD display. When the LAMP TEST key is held for longer than five seconds, the LCD will display the Software Revisions.

## 2.4 Programming Keypad

The programming keypad includes:

- Function keys: DETECTOR, MODULE, OUTPUT, BATTERY LEVELS, NEXT SELECTION, PREVIOUS SELECTION, RECALL LAST ENTRY, and INCREMENT NUMBER
- ENTER key
- Cursor movement keys: ESC/LEFT ARROW key, UP key, RIGHT key, DOWN key
- Alphabetic and numeric keys, with LOWER CASE selection key

Shown below is the Programming Keypad, with descriptions for the keys.

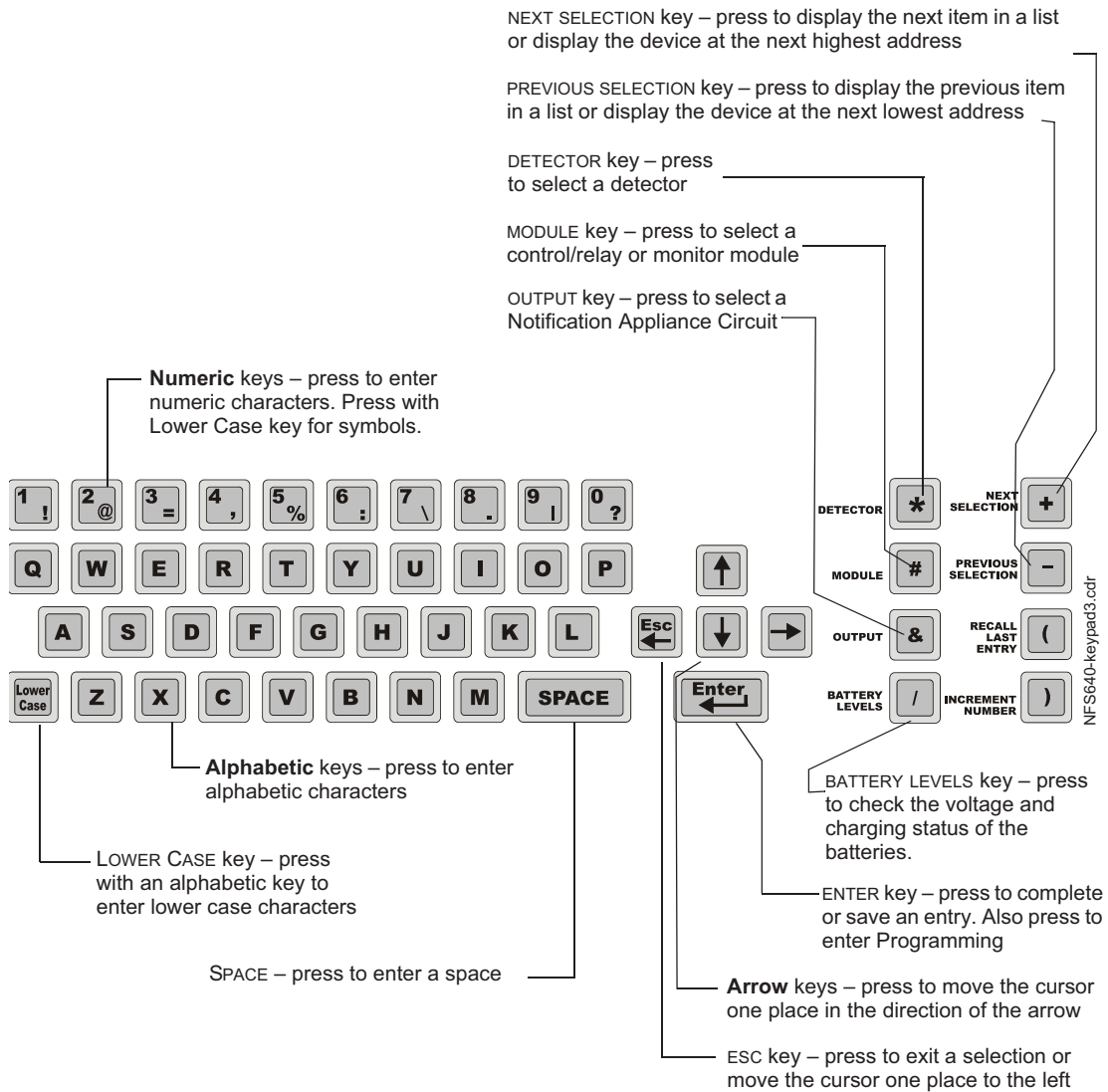


Figure 2.2 Programming Keypad

# Section 3: Operation of the Control Panel

## 3.1 Overview

This section contains instructions for operating the control panel. Listed below are the topics detailed in this section:

Section	Refer to Page
3.2, "Normal Mode of Operation"	page 19
3.3, "Fire Alarm Mode of Operation"	page 20
3.4, "System Trouble Mode of Operation"	page 22
3.5, "Security Alarm Mode of Operation"	page 24
3.6, "Active Supervisory Signal Mode of Operation"	page 25
3.7, "Pre-Alarm Warning Mode of Operation"	page 27
3.8, "Disabled Points Mode of Operation"	page 28
3.9, "Non-Alarm Mode of Operation"	page 29
3.10, "Active Trouble Monitor Mode of Operation"	page 30
3.11, "Output Circuit Trouble Mode of Operation"	page 31
3.12, "Operation of Special System Timers"	page 33
3.13, "Waterflow Circuit Operation"	page 34
3.14, "Style 6 and Style 7 Operation"	page 34

This manual also contains information on operating the control panel in the appendixes, listed as follows:

- Appendix A, "Special Zone Operation", on page 51
- Appendix B, "Intelligent Detector Functions", on page 61
- Appendix C, "Remote Terminal Access", on page 63
- Appendix D, "Point and System Troubles Lists", on page 71

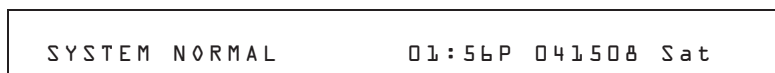


**WARNING:**

When used for CO<sub>2</sub> releasing applications, observe proper precautions as stated in NFPA 12. Do not enter the protected space unless physical lockout and other safety procedures are fully completed. Do not use software disable functions in the panel as lockout.

## 3.2 Normal Mode of Operation

The system operates in Normal mode when no alarms or troubles exist. In Normal mode, the control panel displays a System Normal message as follows



**Figure 3.1 Sample System Normal Message**



In Normal mode, the control panel does the following functions at regular intervals:

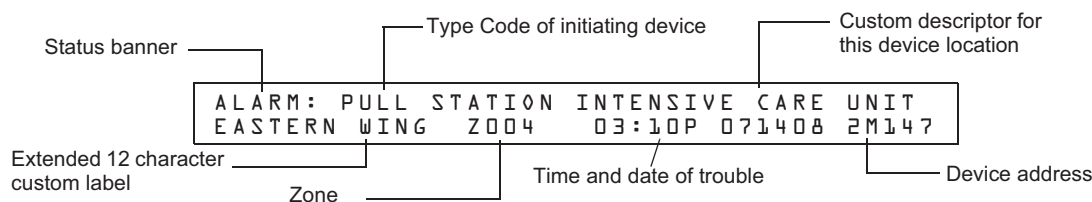
- Polls all SLC devices and the four NACs to check for valid replies, alarms, troubles, circuit integrity, supervisory signals, etc.
- Checks power supply troubles and batteries at 10-second intervals
- Sends a supervisory query on the optional FDU-80 and verifies proper response
- Refreshes the LCD display and the optional FDU-80 display and updates time
- Scans for any keypad or Control Key entries
- Performs a detector automatic test operation
- Tests system memory
- Monitors for microcontroller failure

## 3.3 Fire Alarm Mode of Operation

### 3.3.1 How the Control Panel Indicates a Fire Alarm

When an initiating device (detector or monitor module) activates, the control panel does the following:

- Produces a steady audible tone
- Activates the System Alarm relay (TB4)
- Flashes the FIRE ALARM LED
- Displays a Type Code that indicates the type of device that activated the fire alarm
- Displays ALARM in the status banner on the LCD display, along with information specific to the device, as shown below:



**Figure 3.2 Sample Fire Alarm Display**

- Sends an Alarm message to the LCD display, History buffer and installed printers, FDU-80 annunciators, and CRT-2s.
- Latches the control panel in alarm. (You can not return the control panel to normal operation until you correct the alarm condition and reset the control panel)
- Initiates any Control-By-Event actions
- Starts timers (such as Silence Inhibit, Auto Silence)
- Activates the general alarm zone (Z00)

### 3.3.2 How to Respond to a Fire Alarm

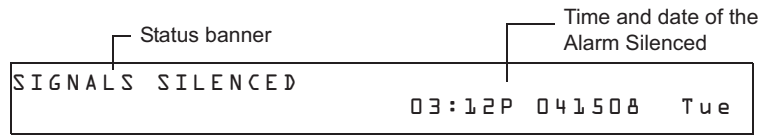
If the control panel indicates a fire alarm, you can do the following:

- To silence only the panel sounder:

Press the ACKNOWLEDGE/SCROLL DISPLAY key. The local sounder will silence and the FIRE ALARM LED will change from flashing to steady.

The control panel will send an acknowledge message to the LCD display, history buffer, and installed printers, FDU-80 annunciators, and CRT-2s.

- To silence the panel sounder and any activated outputs that are programmed as silenceable: Press the SIGNAL SILENCE key. The FIRE ALARM LED and SIGNALS SILENCED LED light steady. The control panel sends an Signal Silenced message to the History buffer and installed printers, FDU-80 annunciators, and CRT-2s. The figure below shows a sample Alarm Silenced message.



**Figure 3.3 Sample Alarm Silenced Message**

1. Check the Alarm message for the location and type of trouble.
2. Correct the condition causing the alarm.
3. When you finish correcting the alarm condition, press the SYSTEM RESET key to return the control panel to normal operation (indicated by the “System Normal” message). The control panel sends a “System Normal” message to the LCD display, History buffer and installed printers, FDU-80 annunciators, and CRT-2s.

### 3.3.3 Interpreting Fire Alarm Type Codes

The Type Code that displays in the Alarm message indicates the function of the point that initiates the fire alarm. For example, a monitor module with a PULL STATION Type Code means that the monitor module connects to a manual pull station. The table below lists the Type Codes that can appear in an alarm message:

Type Code	Latching (Y/N)	Purpose	What it does
<b>Monitor Modules</b>			
Blank	Y	Indicates activation of a device with no description	Lights FIRE ALARM LED and activates CBE
HEAT DETECT	Y	Indicates activation of a conventional heat detector	Lights FIRE ALARM LED and activates CBE
MONITOR	Y	Indicates activation of an alarm-monitoring device	Lights FIRE ALARM LED and activates CBE
PULL STATION	Y	Indicates activation of a manual fire-alarm-activating device, such as a pull station.	Lights FIRE ALARM LED and activates CBE
RF MON MODUL	Y	Indicates activation of a wireless alarm-monitoring device	Lights FIRE ALARM LED and activates CBE
RF PULL STA	Y	Indicates activation of a wireless manual fire-alarm-activating device, such as a pull station	Lights FIRE ALARM LED and activates CBE
SMOKE CONVEN	Y	Indicates activation of a conventional smoke detector attached to an FZM-1	Lights FIRE ALARM LED and activates CBE
SMOKE DETECT	Y	Indicates activation of a conventional smoke detector attached to an FZM-1	Lights FIRE ALARM LED and activates CBE
WATERFLOW	Y	Indicates activation a waterflow alarm switch	Lights FIRE ALARM LED and activates CBE
EVACUATE SW	N	Performs Drill function.	Activates all silenceable outputs
MAN. RELEASE	Y	Indicates activation of a monitor module programmed to a releasing zone to perform a releasing function.	Lights FIRE ALARM LED and activates CBE
MANREL DELAY	Y	Indicates activation of a monitor module programmed for a release output	Lights FIRE ALARM LED and activates CBE
SECOND SHOT	N	Provides second activation of releasing zone after soak timer has expired.	Indicates ACTIVE and activates CBE

**Table 3.1 Fire Alarm Type Codes (1 of 2)**

Type Code	Latching (Y/N)	Purpose	What it does
<b>Detectors</b>			
SMOKE(ION)	Y	Indicates activation of an ion smoke detector	Lights FIRE ALARM LED and activates CBE
SMOKE(DUCT I)	Y	Indicates activation of a duct ion smoke detector	Lights FIRE ALARM LED and activates CBE
SMOKE(PHOTO)	Y	Indicates activation of a photo smoke detector	Lights FIRE ALARM LED and activates CBE
RF_PHOTO	Y	Indicates activation of a wireless photoelectric smoke detector	Lights FIRE ALARM LED and activates CBE
SMOKE(DUCTP)	Y	Indicates activation of a duct photo smoke detector	Lights FIRE ALARM LED and activates CBE
SMOKE(HARSH)*	Y	Indicates activation of a HARSH smoke detector	Lights FIRE ALARM LED and activates CBE
SMOKE(LASER)	Y	Indicates activation of a laser smoke detector	Lights FIRE ALARM LED and activates CBE
SMOKE(DUCTL)	Y	Indicates activation of a duct laser smoke detector	Lights FIRE ALARM LED and activates CBE
SMOKE(BEAM)	Y	Indicates activation of a beam smoke detector	Lights FIRE ALARM LED and activates CBE
SMOKE(DUCTL)	Y	Indicates activation of a duct laser smoke detector	Lights FIRE ALARM LED and activates CBE
AIR REF	Y	Indicates activation of a laser air reference detector.	Lights FIRE ALARM LED and activates CBE
HEAT	Y	Indicates activation of a 190°F intelligent thermal detector	Lights FIRE ALARM LED and activates CBE
HEAT+	Y	Indicates activation of a 190°F adjustable threshold intelligent thermal detector	Lights FIRE ALARM LED and activates CBE
HEAT(ANALOG)	Y	135°F intelligent thermal sensor	Lights FIRE ALARM LED and activates CBE
HEAT (ROR)	Y	15°F per minute rate-of-rise detector	Lights FIRE ALARM LED and activates CBE
SMOKE ACCLIM	Y	Indicates activation of detector (Acclimate Plus™, FSC-851 IntelliQuad), without freeze warning	Lights FIRE ALARM LED and activates CBE
SMOKE (ACCL+)	Y	Indicates activation of detector (Acclimate Plus™, FSC-851 IntelliQuad), with freeze warning	Lights FIRE ALARM LED and activates CBE
SMOKE MULTI*	Y	Multisensor smoke detector	Lights FIRE ALARM LED and activates CBE
*CLIP mode only			

Table 3.1 Fire Alarm Type Codes (2 of 2)

### 3.4 System Trouble Mode of Operation

#### 3.4.1 How the Control Panel Indicates a System Trouble

The system goes into system trouble when the control panel detects an electrical fault. If no fire alarms exist, the control panel does the following:

- Produces a pulsed audible tone
- Activates the Trouble relay (TB4)
- Flashes the SYSTEM TROUBLE LED
- Displays a Type Code that indicates the type of device with a trouble.
- Displays TROUBL in the status banner on the LCD display as well as the type of trouble and information specific to the device, as shown in Figure 3.4 below.
- Sends a Trouble message to the LCD display, history buffer and installed printers, FDU-80 annunciators, and CRT-2s.



**NOTE:** If a fire alarm exists when a trouble exists, the SYSTEM TROUBLE LED lights, but the Alarm message appears in the LCD display.

Typical Trouble message that appears on the LCD display:

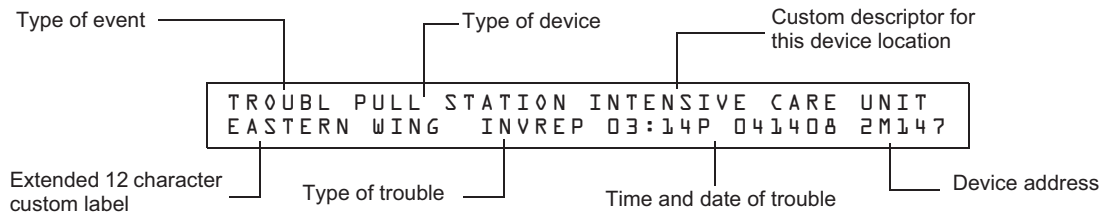


Figure 3.4 Sample Trouble Message

### 3.4.2 How to Respond to a System Trouble

If the control panel indicates a trouble, you can do the following:

1. Press the ACKNOWLEDGE/SCROLL DISPLAY key to silence the panel sounder and switch the SYSTEM TROUBLE LED from flashing to steady—regardless of the number of troubles, alarms, security and supervisory signals.



**NOTE:** Pressing the SIGNAL SILENCE key when only troubles exist, gives the same result as pressing the ACKNOWLEDGE/SCROLL DISPLAY key. The SIGNALS SILENCED LED does not light unless an alarm exists in the system.

2. The control panel sends an Acknowledge message to the History buffer and installed printers, FDU-80 annunciators, and CRT-2s.



Figure 3.5 Sample Acknowledge Message

3. Check the trouble message for the location and type of trouble.

```

TROUBL MONITOR      MODULE ADDRESS  M021 Z00 OPEN CIRCUIT  08:10A 042108 2M021
TROUBL MONITOR      MODULE ADDRESS  M022 Z00 OPEN CIRCUIT  08:12A 042108 2M022
    
```

Figure 3.6 Sample Trouble Messages on CRT-2 or Printer

4. Correct the condition causing the trouble. If the trouble clears, the control panel sends a Clear Trouble message to the History buffer and installed printers FDU-80 annunciators, and CRT-2s.

If all troubles clear and no supervisory signals or fire alarms exist, the control panel does the following:

- Returns to Normal operation (indicated by the “System Normal” message)
- Sends a “System Normal” message to the LCD display, History buffer and installed printers, FDU-80 annunciators, and CRT-2s
- Restores troubles automatically - even if troubles are not acknowledged

If multiple trouble conditions exist in the system, the LCD and optional CRT-2 and FDU-80s automatically step through each trouble every 3 seconds in the following order:

1. Alarms, in order of address
2. Supervisory, in order of address
3. Troubles, in order of address

Press the ACKNOWLEDGE/SCROLL DISPLAY key and the display stops on the current trouble event for 1 minute, then begins to automatically step through remaining troubles. To manually step through remaining troubles, press the ACKNOWLEDGE/SCROLL DISPLAY key.

Refer to Appendix D, “Point and System Troubles Lists”, on page 71 for explanations of troubles that appear on the display.

## 3.5 Security Alarm Mode of Operation

### 3.5.1 How the Control Panel Indicates a Security Alarm

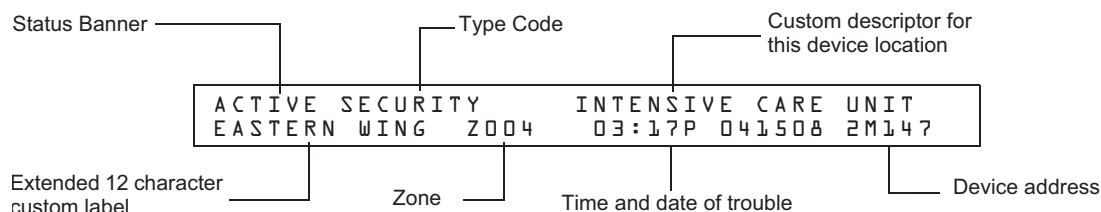
The system goes into Security mode when a monitor module point programmed with a Security Type Code activates. If no fire alarm exists, the control panel does the following:

- Produces a warbling audible tone
- Turns on the Security relay (TB5)
- Flashes the SECURITY LED (blue)
- Displays a Type Code that indicates the type of security alarm being generated
- Displays ACTIVE in the status banner on the control panel, along with information specific to the device
- Sends a Security message to the LCD display, History buffer, and installed printers, FDU-80 annunciators, and CRT-2s
- Sends a Security message to the proprietary receiver via the network, if applicable.



**NOTE:** If a fire alarm exists, and there are silenced alarms (the SIGNALS SILENCED LED is lighted), a Security alarm will resound the panel sounder.

A Typical security message that appears on LCD display:



**Figure 3.7 Sample Security Alarm Message**

### 3.5.2 How to Respond to a Security Alarm

A Security Type Code latches the control panel. To return the control panel to normal operation, you must correct the condition causing the security condition, then reset the control panel. If the control panel indicates a security alarm, take the following action:



**NOTE:** If a fire alarm exists, and there are silenced alarms (the SIGNALS SILENCED LED is lighted), a Security alarm will resound the panel sounder.

1. Press the ACKNOWLEDGE/SCROLL display key to silence the panel sounder and switch the SECURITY LED from flashing to steady—regardless of the number of troubles, alarms, supervisory, and security signals. The control panel sends a Security message to the History buffer and installed printers, FDU-80 annunciators, and CRT-2s.
2. Correct the condition that activated the Security point.

- When you finish correcting the Security condition, press the SYSTEM RESET key to return the control panel to normal operation (indicated by the “System Normal” message). The control panel sends a “System Normal” message to the LCD display, History buffer and installed printers, FDU-80 annunciators, and CRT-2s.

### 3.5.3 Interpreting Security Type Codes

The Type Code that displays in the security alarm message indicates the type of security alarm being generated by the monitor module that initiates the alarm. For example, a monitor module with a Type Code of AREA MONITOR indicates an intruder in a protected premises area. The table below lists the Type Codes that can appear in a security alarm message.

<b>Monitor Modules</b>			
Type Code	Latching (Y/N)	Purpose	What it does
AREA MONITOR	Y	Monitors area surveillance equipment, such as motion detectors	Lights SECURITY LED, activates CBE
SECURITY	Y	Monitors security switches for tampering	Lights SECURITY LED, activates CBE
SYS MONITOR	Y	Monitors critical equipment for security	Lights SECURITY LED, activates CBE

**Table 3.2 Security Type Codes**

## 3.6 Active Supervisory Signal Mode of Operation

### 3.6.1 How the Control Panel Indicates an Active Supervisory

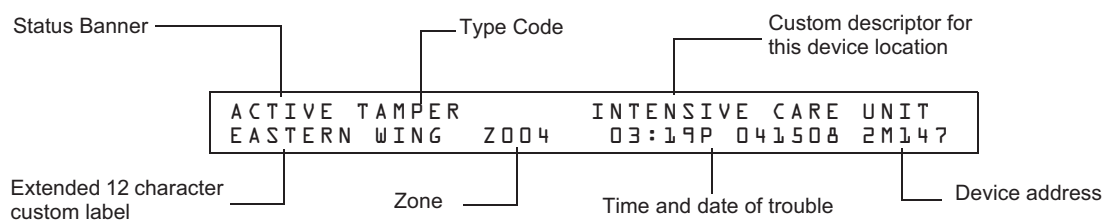
The system goes into Supervisory mode when a monitor module point programmed with a Supervisory type code activates. When a Supervisory point activates, the control panel does the following:

- Produces a warbling audible tone
- Turns on the Supervisory relay (TB5)
- Flashes the SUPERVISORY LED (yellow)
- Displays one of the Type Codes listed in Table 3.3.
- Displays ACTIVE in the status banner on the control panel, along with information specific to the device
- Sends a Supervisory message to the LCD display, History buffer, and installed printers, FDU-80 annunciators, and CRT-2s



**NOTE:** If a fire alarm exists, and there are silenced alarms (the SIGNALS SILENCED LED is lighted), a Supervisory alarm will resound the panel sounder.

A Typical Supervisory message that appears on LCD display:



**Figure 3.8 Sample Supervisory Signal Message**

## 3.6.2 How to Respond to an Active Supervisory

### If a Latching Supervisory Type Code Displays

Some Supervisory Type Codes latch the control panel (Refer to Table 3.3 for a list of these type codes). To return the control panel to normal operation, you must correct the condition causing the supervisory condition, then reset the control panel. Take the following action:



**NOTE:** If a fire alarm exists, and there are silenced alarms (the SIGNALS SILENCED LED is lighted), a Supervisory alarm will resound the panel sounder.

1. Press the ACKNOWLEDGE/SCROLL DISPLAY key to silence the panel sounder and switch the SUPERVISORY LED from flashing to steady—regardless of the number of troubles, alarms, and supervisory signals. The control panel sends a Supervisory message to the History buffer and installed printers, FDU-80 annunciators, and CRT-2s.
2. Correct the condition that activated the supervisory point.
3. When you finish correcting the latching supervisory condition, press the SYSTEM RESET key to return the control panel to normal operation (indicated by the “System Normal” message). The control panel sends a “System Normal” message to the LCD display, History buffer and installed printers, FDU-80 annunciators, and CRT-2s.

### If Non-latching Type Code Displays

Some Supervisory Type Codes do not latch the control panel. (Refer to Table 3.3 for a list of these type codes). The control panel automatically returns to normal operation, when you correct the condition that activates the supervisory point. If the control panel indicates a non-latching supervisory point, take the following action:



**NOTE:** If a fire alarm exists, and there are silenced alarms (the SIGNALS SILENCED LED is lighted), a Supervisory alarm will resound the panel sounder.

1. Press the ACKNOWLEDGE/SCROLL DISPLAY key to silence the panel sounder and switch the SUPERVISORY LED from flashing to steady—regardless of the number of troubles, alarms, and supervisory signals. The control panel sends a Supervisory message to the History buffer and installed printers, FDU-80 annunciators, and CRT-2s.
2. Correct the condition that activated the supervisory point.
3. The control panel automatically returns to normal operation (indicated by the “System Normal” message) and the control panel sends a “System Normal” message to the LCD display, History buffer and installed printers, FDU-80 annunciators, and CRT-2s.

## 3.6.3 How to Interpret Supervisory Type Codes

The Type Code that displays in the Supervisory message indicates the function of the point that initiates the Supervisory. For example, a monitor module with a TAMPER Type Code means that the monitor module connects to a tamper switch.

Type Codes that can appear in an Supervisory message:

<b>Monitor Modules</b>			
Type Code	Latching (Y/N)	Purpose	What it does
WATERFLOW S	Y	Indicates supervisory condition for activated waterflow switch	Lights SUPERVISORY LED and activates CBE
RF SUPERVSRY	N	Monitors a radio frequency device	Lights SUPERVISORY LED and activates CBE
LATCH SUPERV	Y	Indicates latching supervisory condition	Lights SUPERVISORY LED and activates CBE

**Table 3.3 Supervisory Type Codes (1 of 2)**



<b>Monitor Modules</b>			
<b>Type Code</b>	<b>Latching (Y/N)</b>	<b>Purpose</b>	<b>What it does</b>
TRACK SUPERV	N	Indicates tracking supervisory condition	Lights SUPERVISORY LED and activates CBE
SPRINKLR SYS	Y	Indicates activation of sprinkler system	Lights SUPERVISORY LED and activates CBE
TAMPER	Y	Indicates activation of tamper switch	Lights SUPERVISORY LED and activates CBE
<b>Detectors</b>			
SUP.T(DUCTI)	N	Ion detector that indicates supervisory (non-alarm) condition	Lights SUPERVISORY LED and activates CBE
SUP.L(DUCTI)	Y	Ion detector that indicates supervisory (non-alarm) condition	Lights SUPERVISORY LED and activates CBE
SUPT(DUCTL)	N	Laser detector that indicates supervisory (non-alarm) condition	Lights SUPERVISORY LED and activates CBE
SUPL(DUCTL)	Y	Laser detector that indicates supervisory (non-alarm) condition	Lights SUPERVISORY LED and activates CBE
SUP.T(DUCTP)	N	Photo detector that indicates supervisory (non-alarm) condition	Lights SUPERVISORY LED and activates CBE
SUP.L(DUCTP)	Y	Photo detector that indicates supervisory (non-alarm) condition	Lights SUPERVISORY LED and activates CBE
SUPT(PHOTO)	N	Photo detector that indicates supervisory (non-alarm) condition	Lights SUPERVISORY LED and activates CBE
SUP.L(PHOTO)	Y	Photo detector that indicates supervisory (non-alarm) condition	Lights SUPERVISORY LED and activates CBE
SUP.T(ION)	N	Ion detector that indicates supervisory (non-alarm) condition	Lights SUPERVISORY LED and activates CBE
SUP.L(ION)	Y	Ion detector that indicates supervisory (non-alarm) condition	Lights SUPERVISORY LED and activates CBE
SUP.L(LASER)	Y	Laser detector that indicates supervisory (non-alarm) condition	Lights SUPERVISORY LED and activates CBE
SUP.T(LASER)	N	Laser detector that indicates supervisory (non-alarm) condition	Lights SUPERVISORY LED and activates CBE

Table 3.3 Supervisory Type Codes (2 of 2)

## 3.7 Pre-Alarm Warning Mode of Operation

### 3.7.1 How the Control Panel Indicates a Pre-Alarm Warning

The control panel activates a Pre-Alarm Warning if a detector exceeds the programmed Pre-Alarm Alert or Action level. When a detector activates a Pre-Alarm, the control panel does the following:

- Pulses the panel sounder
- Flashes the PRE-ALARM LED
- Activates the Pre-Alarm zone (F9)
- Sends a Pre-Alarm message to the LCD display, History buffer and installed printers, FDU-80 annunciators, and CRT-2s
- Displays a PREALARM status banner, the Type Code of the detector, and the Pre-Alarm level (Alert or Action) on the LCD display, along with information specific to the device as shown in Figure 3.9.

### 3.7.2 How to Respond to a Pre-Alarm Warning

#### Pre-Alarm Alert and Action Levels

The Pre-Alarm function is a programmable option which determines the system's response to real-time detector sensing values above the programmed setting. Use the Pre-Alarm function if you want to get an early warning of incipient or potential fire conditions. The Pre-Alarm function provides one of two levels of Pre-Alarm as follows:

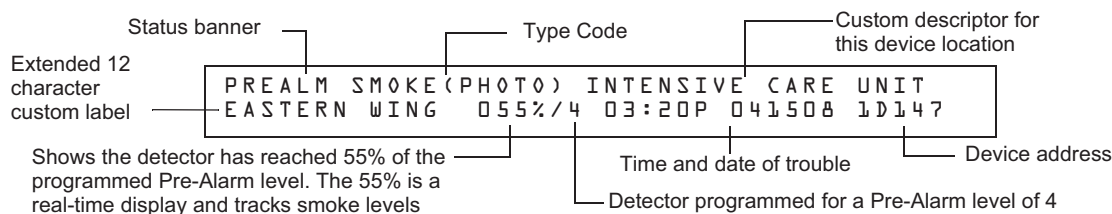


**NOTE:** For detailed information on Pre-Alarm applications, refer to the *NFS2-640 Programming Manual*.

- Alert – a non-latching condition that causes a Pre-Alarm when a detector reaches the programmed Pre-Alarm level.
- Action – a latching condition that causes a Pre-Alarm when a detector reaches the programmed Pre-Alarm level.

## Responding to a Pre-Alarm Warning

The Pre-Alarm screen display is the same for both alert and action conditions. Following is a sample screen for a Pre-Alarm message.



**Figure 3.9 Sample of an Alert Pre-Alarm Message**

An Alert Pre-Alarm automatically restores to normal when the detector sensitivity, programmable to one of nine settings, drops below the programmed Alert level. Zone F09 automatically clears when no Pre-Alarm conditions exist.

An Action Pre-Alarm latches until you reset the system - even if the detector sensitivity drops below the Action level. Zone F09 activates - but Zone Z00 (general alarm) and the trouble and alarm relays do not activate. The fifth zone programmed, not the first four, in the detector's CBE activates. A subsequent alarm condition for this detector clears the Action indication from the LCD display.

### Interpreting Pre-Alarm Type Codes

The Type Code that displays in the Pre-Alarm warning indicates the function of the point that initiates the Pre-Alarm warning. Refer to the Detectors section of Table 3.1 for the Type Codes that can appear in a Pre-Alarm warning, and for descriptions of those Type Codes.

## 3.8 Disabled Points Mode of Operation

The control panel indicates disabled points by displaying a screen for each disabled detector, monitor module, and control/relay module. Disabled points do not cause an alarm or any Control-by-Event activity. If more than one point is disabled, the control panel displays by priority, mimicking the alarms.



**CAUTION:**  
Disabling a zone disables all input and output devices associated with the zone.

When one or more points are disabled, the control panel does the following:

- Holds all disabled output points in the off-state
- Flashes the SYSTEM TROUBLE LED
- Lights the POINT DISABLED LED
- Sends a Disabled Point message to the LCD display, History buffer and installed printers, FDU-80 annunciators, and CRT-2s
- Displays a message for each disabled point

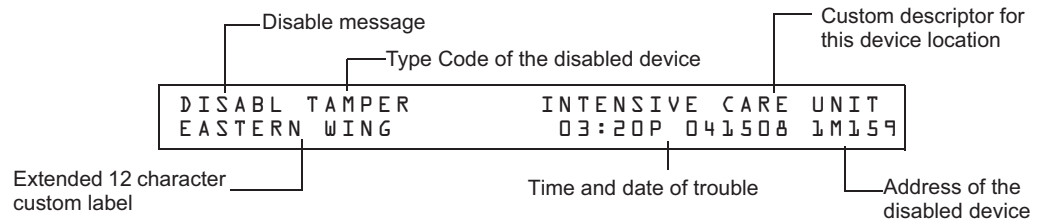


Figure 3.10 Sample Disabled Point Message

### 3.9 Non-Alarm Mode of Operation

#### 3.9.1 Purpose of Non-Alarm Points

Non-Alarm points are addressable monitor modules programmed with one of the Non-Alarm Type Codes listed in Table 3.4. Non-Alarm points, except Non-Fire, operate like monitored system functions that can produce troubles—but with the differences shown in the following sections.

<b>Monitor Modules</b>			
Type Code	Latching (Y/N)	Purpose	What it does
ACCESS MONTR	N	Used for monitoring building access	Activates CBE
ACK SWITCH	N	Performs Acknowledge function	Silences panel sounder, gives an Acknowledge message on the panel LCD
ALLCALL PAGE	N	Activates all speaker circuits for paging	Activates speakers
DRILL SWITCH	N	Performs Drill function	Activates silenceable outputs
FIRE CONTROL	N	Used for air handler shutdown, intended to override normal operating automatic functions	Activates CBE, does NOT light an indicator at the control panel
NON-FIRE	N	Used for energy management or other non-fire situations. Does not affect operation of the control panel	Activates CBE, does NOT light an indicator at the control panel
PAS INHIBIT	N	Inhibits Positive Alarm Sequence	Inhibits Positive Alarm Sequence
RESET SWITCH	N	Performs Reset function	Resets control panel
SIL SWITCH	N	Performs Signal Silence function	Turns off all activated silenceable outputs
TELE PAGE	N	Performs function of Page Button on FFT-7	Allows remote paging to a fire area
ABORT SWITCH	N	Indicates Active at the panel	Aborts activation of a releasing zone

Table 3.4 Non-Alarm Type Codes

#### 3.9.2 How the Control Panel Indicates an Active Fire Control

Activation of a FIRE CONTROL point causes the control panel to do the following:

- Initiate the monitor module Control-by-Event
- Send a message to the LCD display, History buffer and installed printers, FDU-80 annunciators, and CRT-2s
- Display an ACTIVE status banner and FIRE CONTROL Type Code on the LCD display, along with information specific to the device

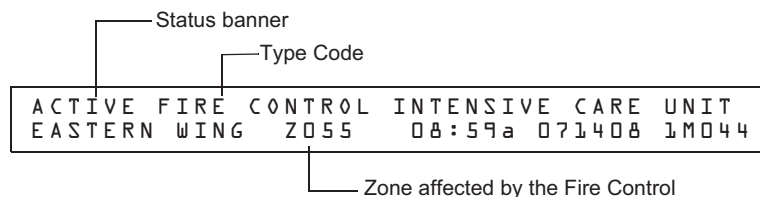


Figure 3.11 Sample Fire Control Point Display

### 3.9.3 How the Control Panel Indicates an Active Non-Fire Point

Non-Fire point operation does not affect control panel operation, nor does it display a message at the panel LCD. Activation of a Non-Fire point activates CBE—but does not cause any indication on the control panel. For example, you can program a Non-Fire point to turn lights in a zone to a lower setting when activated. In this case, when the point activates the control panel activates the point’s CBE to turn the lights down without any audio or visual indication on the control panel.

## 3.10 Active Trouble Monitor Mode of Operation

### 3.10.1 How the Control Panel Indicates an Active Trouble Monitor

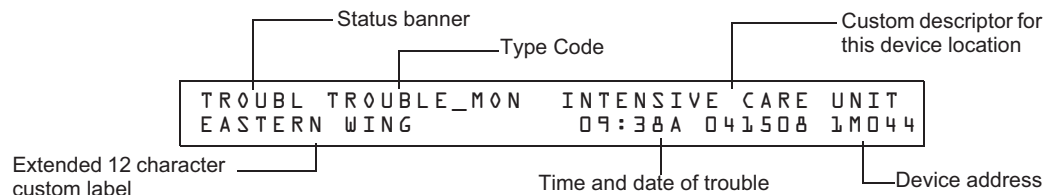
Trouble Monitor Points are monitor modules programmed with the following Type Codes:

Type Code	Latching (Y/N)	Device Function	Point Function
AUDIO SYSTEM	N	Used for monitoring audio equipment audio amplifiers or associated equipment	Indicates trouble
EQUIP MONITR	N	Used for recording access to monitored equipment	Activates CBE
POWER MONITR	N	Used to monitor remote power supplies or other external equipment	Indicates trouble
TROUBLE MON	N	Used to monitor remote power supplies or other external equipment	Indicates trouble

**Table 3.5 Trouble Monitor Type Codes**

These types of monitor modules operate like monitored system functions that can produce troubles—but with the following differences:

- The LCD display status banner displays ACTIVE as shown:



**Figure 4 Sample Trouble Monitor Point Message**

- The monitor module is non-latching: the module will return to normal when the trouble condition no longer exists.
- The monitor modules activate Control-by-Event
- The panel trouble relay transfers (TB4)

### 3.10.2 How to Respond to an Active Trouble Monitor

If the control panel indicates an active Trouble Monitor Point, take the following action:

1. Press the ACKNOWLEDGE/SCROLL DISPLAY key to silence the panel sounder and switch the SYSTEM TROUBLE LED from flashing to steady—regardless of the number of troubles, alarms, and supervisory signals.
2. The control panel sends an Acknowledge message to the History buffer and installed printers, FDU-80 annunciators, and CRT-2s. Check the trouble message for the location and type of trouble.
3. Correct the condition causing the trouble.
4. When the trouble condition is corrected, the panel will return to normal operation (indicated by the “System Normal” message).
5. The control panel sends a “System Normal” message to the LCD display, History buffer and installed printers, FDU-80 annunciators, and CRT-2s.

## 3.11 Output Circuit Trouble Mode of Operation

### 3.11.1 Overview

Output circuits include NACs, Control/Relay Modules, and Transponder Points. This section contains a description of control panel operation for each type of output circuit.

- Four NACs are included on the control panel
- Control/Relay Modules connected to the control panel on an SLC
- Transponder Points: XPC-8 (CLIP only), or XP6-C (CLIP or FlashScan)

<b>Trouble Type Codes for Control Modules and NAC Circuits</b>			
<b>Type Code</b>	<b>Silenceable (Y/N)</b>	<b>Configuration</b>	<b>Device Function</b>
CONTROL	N	NAC	Supervised NAC
RELAY	N	FORM-C relay	Relay Output
BELL CIRCUIT	N	NAC	Supervised NAC for notification appliance
STROBE CKT	N	NAC	Supervised NAC for notification appliance
HORN CIRCUIT	N	NAC	Supervised NAC for notification appliance
AUDIBLE CKT	N	NAC	Supervised NAC for notification appliance
SPEAKER	N	NAC	Supervised NAC for speaker circuit
REL END BELL	N	NAC	Supervised NAC for notification appliance
blank	N	NAC	Supervised NAC for undefined device
RELEASE CKT	N	NAC	Directs outputs to perform a releasing function.
REL CKT ULC	N	NAC	Directs outputs to perform a release function as required by ULC.
REL AUDIBLE	N	NAC	NAC, activated upon release
NONRESET CTL*	N	NAC	Relay output, unaffected by "System Reset" command
TELEPHONE	N	NAC	Standard Telephone circuit
REL CODE BELL**	N	NAC	Supervised NAC (NFS2-640 NAC only)
INSTANT RELE	N	NAC	NAC, short = normal; supervised for open circuits and ground faults. Always non-silenceable and switch-inhibited.
ALARMS PEND	N	NAC	Output that will activate upon receipt of an alarm condition, and remain in the alarm state until all alarms have been acknowledged.
CONTROL NAC**	N	NAC	Supervised NAC
GEN ALARM	Y		Control Module, an XPC-8 circuit, or an XP6-C configured as a Municipal Box Transmitter for NFPA 72 Auxiliary Fire Alarm Systems application. This Type ID can also be used for general alarm activation.
GEN SUPERVIS	Y		Control Module, an XPR-8 relay, or an XP6-R activated under any Supervisory condition (includes sprinkler type).
GEN TROUBLE	Y		Control Module, an XPR-8 relay, or an XP6-R activated under any System Trouble condition.
GENERAL PEND	Y		Control Module, an XPC-8 circuit, or an XP6-C that will activate upon receipt of an alarm and/or trouble condition, and remain in the ON state until all events have been ACKNOWLEDGED.
TROUBLE PEND	N		Control Module, an XPC-8 circuit, or an XP6-C that will activate upon receipt of a trouble condition, and remain in the ON state until all troubles have been ACKNOWLEDGED.
* Type Code is Control Module type code only.			
** Type Code is NAC Circuit type code only.			

**Table 3.6 Control Module and NAC Circuit Trouble Type Codes**

### 3.11.2 How the Control Panel Indicates a NAC Trouble

A Trouble occurring on a NAC causes the control panel to do the following:

- Produce a pulsed audible tone
- Flash the SYSTEM TROUBLE LED
- Turn on the Trouble relay (TB4)
- Send a message to the LCD display, History buffer and installed printers, FDU-80 annunciators, and CRT-2s
- Display a TROUBL status banner and a CONTROL Type Code on the LCD display, along with information specific to the device

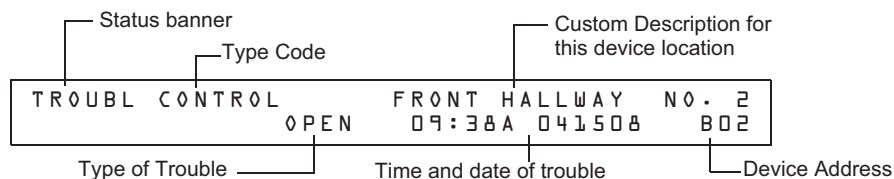


Figure 3.1 Sample of a NAC in Trouble Message

### 3.11.3 How the Control Panel Indicates a Control/Relay Trouble

A trouble occurring on a control/relay module or control/relay transponder causes the control panel to do the following:

- Produce a pulsed audible tone
- Flash the SYSTEM TROUBLE LED
- Turn on the Trouble relay (TB4)
- Send a message to the LCD display, History buffer and installed printers FDU-80 annunciators, and CRT-2s
- Display a TROUBL status banner and CONTROL Type Code on the LCD display, along with information specific to the device

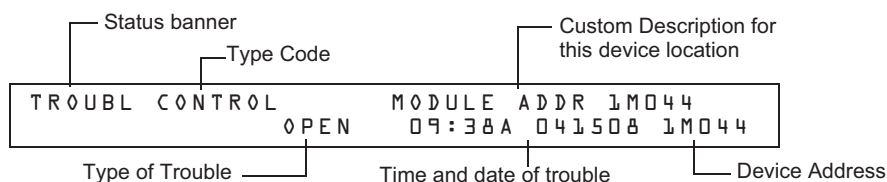


Figure 3.2 Sample of a Control/Relay Module in Trouble Message

### 3.11.4 How to Respond to a NAC or Control/Relay Trouble

If the control panel indicates an active NAC or Control/Relay Trouble, take the following action:

1. Press the ACKNOWLEDGE/SCROLL DISPLAY key to silence the panel sounder and switch the SYSTEM TROUBLE LED from flashing to steady—regardless of the number of troubles, alarms, and supervisory signals.
2. The control panel sends an Acknowledge message to the History buffer and installed printers, FDU-80 annunciators, and CRT-2s. Check the trouble message for the location and type of trouble.
3. Correct the condition causing the trouble.
4. When the trouble condition is corrected, the panel will return to normal operation (indicated by the “System Normal” message).
5. The control panel sends a “System Normal” message to the LCD display, History buffer and installed printers, FDU-80 annunciators, and CRT-2s.

## 3.12 Operation of Special System Timers

### 3.12.1 What are System Timers?

There are user-programmable time delays for three specific functions: the Auto Silence Timer, the Alarm Verification Timer, and the Silence Inhibit Timer. Figure 3.3 shows a sample System Function Selection screen with system timer settings. For instructions on changing system functions, refer to the *NFS2-640 Programming Manual*.

### 3.12.2 How to View System Timer Selections

You can use the Read Status Entry option (explained in Chapter 4) to view the current selection for the System Timers. To do so, press the keys shown below in sequence:



The LCD display shows the current selections for System Functions, which includes the three system timers.

Sample LCD display of a System Function screen with system timer selections:

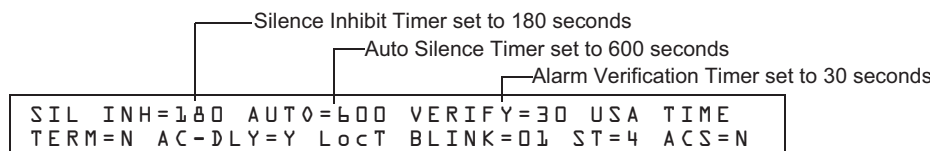


Figure 3.3 Sample System Function Selection Screen

### 3.12.3 How System Timers Work

The control panel can operate with special system timers: Auto Silence Timer, Alarm Verification Timer and Silence Inhibit Timer.

#### Auto Silence Timer

A timer that functions like pressing the SIGNAL SILENCE key. When the Auto Silence Timer reaches its programmed value (600-900 seconds), the control panel automatically shuts off all active outputs programmed as silenceable.

#### Alarm Verification Timer

A timer that directs the control panel to ignore a fire alarm for a smoke detector, programmed for Alarm Verification, while the Alarm Verification Timer is counting. Table 3.7 contains a summary of how the Alarm Verification Timer works.

If	The control panel does this
A second fire alarm occurs while the Alarm Verification Timer is counting	Ignores the Alarm Verification Timer
The Alarm Verification Timer elapses and a fire alarm still exists	Activates the fire alarm
The Alarm Verification Timer expires and a fire alarm no longer exists	Increments the Alarm Verification counter (up to 99) for the device and returns to normal operation

Table 3.7 Alarm Verification Timer Operation

#### Silence Inhibit Timer

A timer that disables the SIGNAL SILENCE key function and inhibits reset during countdown for the programmed time (0-300 seconds) when a fire alarm occurs. A Silence Inhibit Timer starts at the first fire alarm. Subsequent alarms will not restart the timer until the alarm condition is completely resolved and a panel reset is performed.



### 3.13 Waterflow Circuit Operation

If a monitor module programmed with a WATERFLOW Type Code initiates a fire alarm, the control panel disables the SIGNAL SILENCE key and the Auto Silence Timer. Refer to the *NFS2-640 Installation Manual* for information on Waterflow circuits.

### 3.14 Style 6 and Style 7 Operation

Style 6 and Style 7 are supervised methods of communicating with addressable devices. If the control panel detects a trouble (open or short), it will attempt to drive both ends of the loop, maintaining communication in an unsupervised method. The trouble will display on the panel as a Style 6 trouble until you correct the condition. Style 7 configuration of the SLC requires the use of ISO-X isolator modules.

# Section 4: Read Status Operation

## 4.1 Introduction

This section contains instructions and sample screens to show how to access all Read Status functions and menus. For information on Read Status using a CRT-2 refer to “Remote Terminal Access” on page 63.

## 4.2 What is Read Status?

Read Status is a control panel function that lets you view system program information—but not change any programmed settings. The Read Status function lets you do the following:

- View Read Status information without entering a password.
- Enter and operate Read Status functions while the control panel provides full fire protection.
- View Read Status information while a fire alarm or trouble condition exists.



---

**NOTE:** If a fire alarm or trouble occurs while you are in Read Status, the control panel automatically exits Read Status operation and displays the new fire alarm or trouble.

---

### 4.2.1 Quick Reference Key Sequences



For quick reference, in the left margin next to each Read Status option is a block that shows the key sequence needed to view that option.



For example, the block to the left shows how to display the “Read Point” screen:

## 4.3 Entering Read Status

To enter Read Status, follow these steps:

1. From the “System Normal” screen, press the ENTER key. The control panel displays the “Entry” screen as shown below;

```
1=PROGRAMMING      2=READ STATUS ENTRY
(ESCAPE TO ABORT)
```

2. From the “Entry” screen, press the 2 key. The control panel displays the “Read Status Options” screen as shown below:

```
READ POINT=0 HIST=2 ALARM HIST=4 <ENTER>
PRNT POINT=1 HIST=3 ALARM HIST=5 <ENTER>
```

## 4.4 Viewing and Printing a Read Status

To view or print Read Status information follow the instructions below:

Option	Press	Lets you
Read Point	0 key, ENTER key	View information for a detector, module, NAC or zone
Print Points	1 key, ENTER key	Print information for all installed points in the system
Read History	2 key, ENTER key	Display the total number of events in the History buffer and step through each event in sequence
Print History	3 key, ENTER key	Print the contents of the History buffer (up to 800 events)
Read Alarm History	4 key, ENTER key	View a display of the number of alarms in the Alarm History buffer, then scroll through each alarm event
Print Alarm History	5 key, ENTER key	Print the contents of the Alarm History buffer (up to 200 events)



**NOTE:** If attempting to read a point that is not installed, the control panel displays “Not Installed”.

During all Read Status operations (except print operations) the control panel starts a 2-minute timer each time you press a key. If the control panel does not detect a key press for 2 minutes, the control panel exits Read Status and returns to the “System Normal” display.

In Read Status, you can also do the following:

- Press the ESC key to delete the previous entry.
- Press the SYSTEM RESET key to abort Read Status.

### 4.4.1 How to View Read Status of Devices, Zones, & System Settings

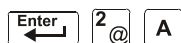
#### Overview

Read Point options 0, 2, and 4 in the Read Status Screen let you display and view information for devices and zones programmed into the control panel, as well as view system and annunciator settings. This section provides instructions and sample displays so you can view Read Status.

Topics covered in this section:

To view Read Status for	Refer to
Intelligent Detectors	“How to View Read Status for a Detector” on page 37
Control/relay and Monitor modules	“How to View Read Status for a Control/Relay or Monitor Module” on page 38
NAC	“How to View Read Status for a NAC” on page 39
Software Zones (Z01-Z99)	“How to View Read Status for a Software Zone (Z01-Z99)” on page 40
Special Zones (F0-F9)	“How to View Read Status for a Special Zone (F0-F9)” on page 40
Releasing Zones (R0-R9)	“How to View Read Status for a Releasing Zone (R0-R9)” on page 41
System Functions	“How to Read Status for System Functions” on page 41
Annunciator Selections	“How to Read Status for Annunciator Selections” on page 42

## How to Display the Total of Installed Devices



To view the total number of installed devices, enter the “Read Status” screen by pressing the ENTER key, then **2**, then **A**. A screen similar to the following will appear:

```
L1:159Dets, 159Mods  L2:055Dets, 047Mods
Panel Outputs: 64  Bells: 04
SB L1:000          SB L2:000
```

## How to Display a Point or Zone for Read Status



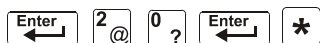
From the “Read Status” screen, press **0**, then press the ENTER key to display the “Read Point Entry” screen as shown below:

```
ZONE=Z,AA,E      DETECTOR=#,L,AAA,E
MODULE=#,L,MAA,E  OUTPUT CKT=B,AA,E
```

- To view a detector, press DETECTOR **\***, SLC number, detector SLC address, ENTER.
- To view a zone, press **Z**, zone number, ENTER.
- To view a monitor or control/relay module, press MODULE **#**, SLC number, module SLC address, ENTER.
- To view a NAC, press OUTPUT **&**, two-digit address, (for example 01 for B01, etc.), ENTER.

When you select a device or a zone, the control panel displays information for the device or zone, but does not send this information to the serial ports or the History buffer.

## How to View Read Status for a Detector



SLC number followed by three digit address

**+** next device

**-** previous device

From the “Read Status” screen, press **0**, then press the ENTER key. You can now view Read Status for a detector as follows: press DETECTOR, enter the SLC number followed by the three digit address, then press the ENTER key. For example, to read the status of detector 1D002: press DETECTOR, enter the SLC number (1), enter address 002, then press the ENTER key. The control panel now displays information about the detector, as shown in Figure 4.1.

The display and descriptions of the fields are shown below:

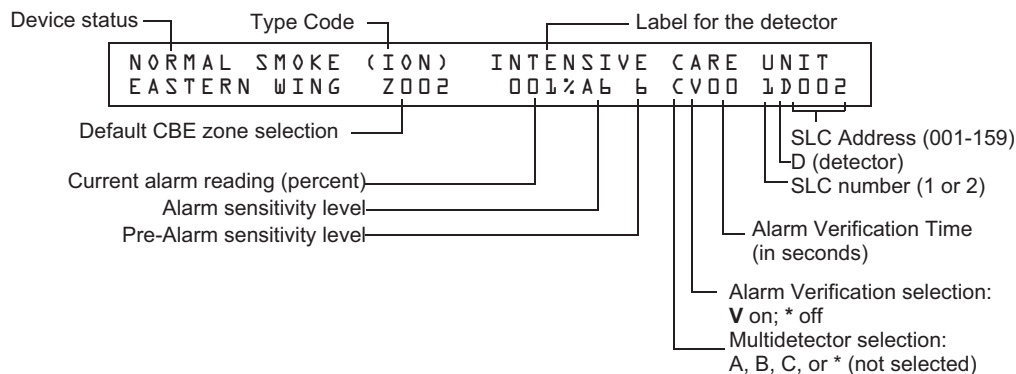


Figure 4.1 Sample Detector Read Status Display

- **Device Status** The status of the detector: Normal, Alarm, or Test.
- **Type Code** The software Type Code that identifies the type of detector. (Refer to “Point Programming” in the *NFS2-640 Programming Manual*.)
- **Default CBE Zone Selection** This is the first zone in the 5 zone CBE list. Defaults are Zone 001 (Heat detectors) Zone 002 (Ion detectors) Zone 003 (Photo detectors) Zone 004 (Laser detectors) Zone 005 (Multisensor). Values may differ depending on point programming.
- **Current alarm reading (xxx%)** The current alarm reading of the detector, as a percentage of the alarm sensitivity setting.
- **Alarm sensitivity level (Ax)** The alarm sensitivity (x=1-9) entered in the Detector Sensitivity Screen.
- **Pre-Alarm sensitivity level** The Pre-Alarm Sensitivity (1-9; 0 = Pre-Alarm not used) entered in the Detector Settings Screen.

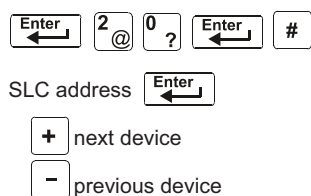


**NOTE:** Refer to “Detector Sensitivity Settings” in the *NFS2-640 Programming Manual* for more information on the Pre-Alarm and Alarm Sensitivity settings

- **Cooperative Multi-Detector selection** A smoke detector programmed to evaluate readings from nearby detectors in making Alarm or Pre-Alarm decisions. Cooperative Multi-Detector sensing also allows the combination of ionization with photoelectric technology in reaching an alarm decision.
  - \* – Multi-not used.
  - A** – combines the detector’s alarm decision with the next SLC address above.
  - B** – combines the detector’s alarm decision with the next SLC address below.
  - C** – combines the detector’s alarm decision with the next SLC address above and the next SLC address below.
- **Alarm Verification (\* or V)**
  - \* – Alarm Verification not programmed for this detector.
  - V** – Alarm Verification enabled.

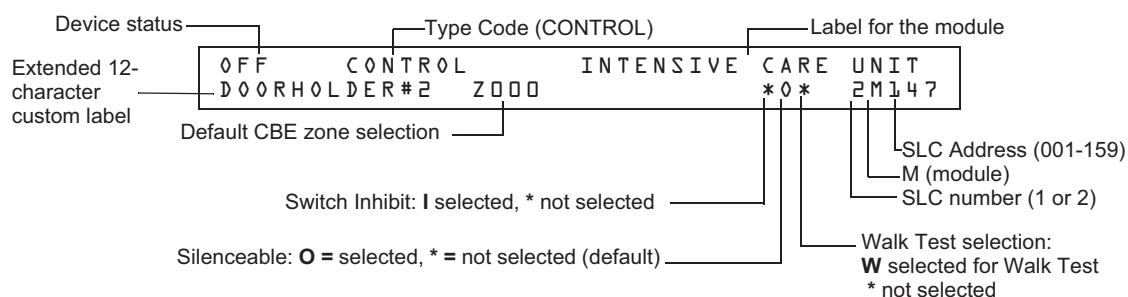
Alarm Verification is a user-defined global time function that can reduce the number of nuisance alarms. Refer to page page 33 for more information.
- **Device SLC Address** The SLC address of the detector.

### How to View Read Status for a Control/Relay or Monitor Module



From the “Read Status” screen, press **0**, then press the ENTER key. You can now view Read Status for a monitor or a control/relay module as follows: press MODULE, enter the SLC address, then press the ENTER key. For example, to read the status of a FCM-1 module 2M147: press MODULE, enter 2 then 147, then press the ENTER key. The control panel now displays information about the module as shown in Figure 4.2.

The display and descriptions of the fields are shown below:



**Figure 4.2 Sample Control/Relay or Monitor Module Read Status Display**

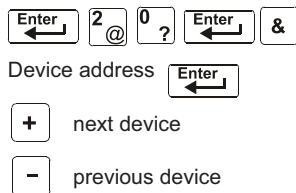
- **Device Status** The status of the module: control/relay module [On (device active) OFF (device not active)] or monitor module (Normal, Alarm, or Test).
- **Type Code** The software Type Code that identifies the type of module. (Refer to “Point Programming” in the *NFS2-640 Programming Manual*.)
- **CBE list** Only the first zone in the device’s CBE list will be displayed.
- **Device SLC Address** The SLC address of the module.
- **Switch Inhibit (control/relay module only)** Displays whether the remote ON/OFF capability of the device is inhibited. (I=on; \*=off).
- **Silenceable (control/relay module only)** A selection that specifies if the device can be silenced during an alarm by pressing the signal silence key. Possible values are:  
 \* = output nonsilenceable  
 F = silenceable, resound by fire alarm  
 U = silenceable, resound by supervisory alarm  
 B = silenceable, resound by security alarm  
 T = silenceable, resound by trouble  
 O = silenceable, does not resound



**NOTE:** If the “Strobe” Type ID is used with System Sensor Strobe synchronization, F, U, B, T, or O will silence the entire circuit, “\*” will silence the horn portion only.

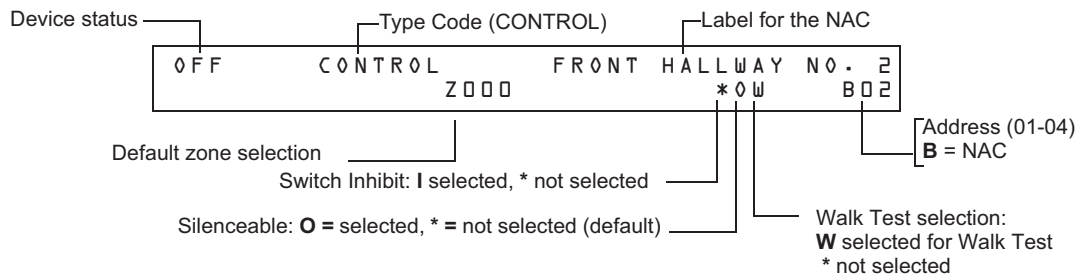
**Walk Test (control/relay module only)** A selection that specifies if the device will activate during a Walk Test.

### How to View Read Status for a NAC



From the “Read Status” screen, press **0**, then press the ENTER key. You can now view Read Status for a NAC as follows: press OUTPUT, enter the device address, then press the ENTER key. For example, to read the status of NAC 0-2: press OUTPUT, enter 02, then press the ENTER key. The control panel now displays information for a NAC as shown in Figure 4.3.

The display and descriptions of the fields are shown below:



**Figure 4.3 Sample NAC Read Status Display**

- **Device Status** The status of the device: ON (device active) OFF (device not active).
- **Type Code** The software Type Code that identifies the type of NAC. Refer to “Appendix F - Type Codes” in *NFS2-640 Programming Manual*.
- **CBE List** Only the first zone in the NAC’s CBE list will be displayed here.
- **Device Address** The address of the NAC (01-04)
- **Switch Inhibit** A selection for disabling the switch function for the control/relay or transponder output circuit. (I=on; \*=off).

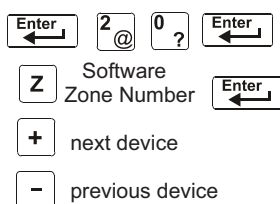
- Silenceable** A selection that specifies if the device can be silenced during an alarm by pressing the SIGNAL SILENCE key. Possible values are:
  - \* = output nonsilenceable
  - F = silenceable, resound by fire alarm
  - U = silenceable, resound by supervisory alarm
  - B = silenceable, resound by security alarm
  - T = silenceable, resound by trouble
  - O = silenceable, does not resound



**NOTE:** If the “Strobe” Type ID is used with System Sensor Strobe synchronization, F,U, B, T, or O will silence the entire circuit, “\*” will silence the horn portion only.

- Walk Test** A selection that specifies if the device will activate during a Walk Test.

### How to View Read Status for a Software Zone (Z01-Z99)



From the “Read Status” screen, press 0, then press the ENTER key. You can now view Read Status for a Software Zone as follows: press Z, enter the zone number (01-99), then press the ENTER key. For example, to read the status of Software Zone 07: press Z, enter 07, then press the ENTER key. The control panel now displays information for a Software Zone as shown below.

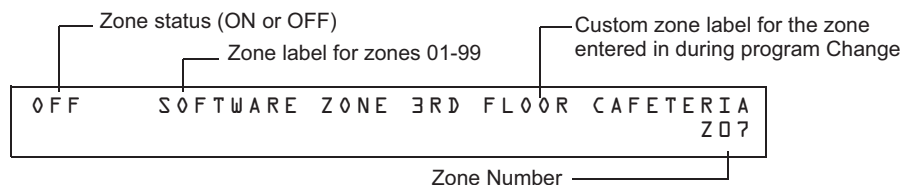
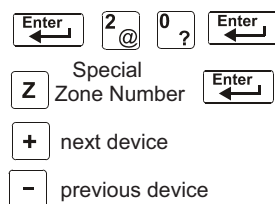


Figure 4.4 Sample Software Zone Read Status Display

### How to View Read Status for a Special Zone (F0-F9)



From the “Read Status” screen, press 0, then press the ENTER key. You can now view Read Status for a Special Zone as follows: press Z, enter the zone number (F0-F9), then press the ENTER key. For example, to read the status of Special Zone F8: press Z, enter F8, then press the ENTER key. The control panel now displays information for a Special Zone as shown below.



**NOTE:** The zone label depends on the type of Special Zone. For example, CODING FUNCTION CODE TYPE for F8.

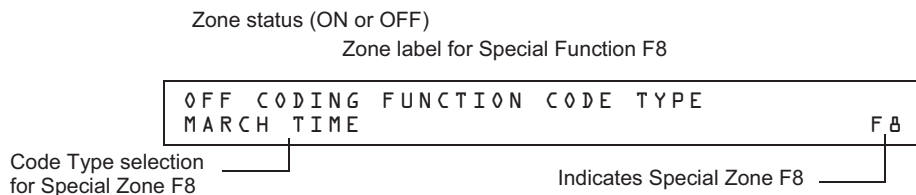
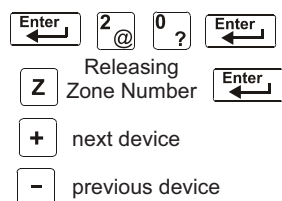


Figure 4.5 Sample Special Zone Read Status Display



## How to View Read Status for a Releasing Zone (R0-R9)



From the “Read Status” screen, press **0**, then press the ENTER key. You can now view the Read Status of a Releasing Zone as follows: press **Z**, enter the zone number (R0-R9), then press the ENTER key. For example, to read the status of Releasing Zone R0, enter **Z**, enter R0, then press the ENTER key. The control panel now displays information for a Releasing Zone as shown below.

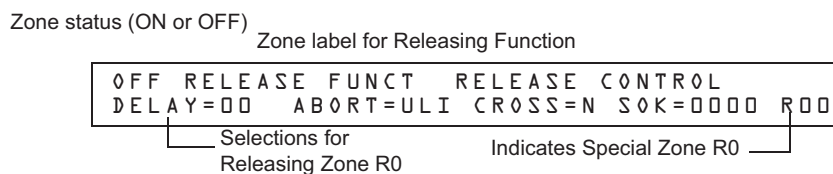
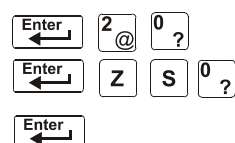


Figure 4.6 Sample Releasing Zone Read Status Display

## How to Read Status for System Functions



The “System Functions” screen specifies global settings for the control panel. From the “Read Status” screen, press **0**, then press the ENTER key. You can now view Read Status for System Functions as follows: press **Z**, enter **S0**, press the ENTER key. Shown below is a sample display and description of items for the Read Status of System Functions:

```

SIL INH=000  AUTO=000  VERIFY=30  USA TIME
TERM=N  AC_DLY=Y  LocT  BLINK=01  ST=4  ACS=N
  
```

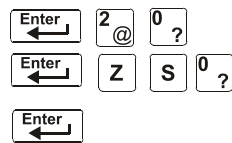
Parameter	Description	Settings
SIL INH=000	Silence Inhibit timer in seconds. Required in Canada and some areas of the USA.	000 = no timer; or the timer duration in seconds up to 300.
AUTO=000	Auto Silence Timer in seconds.	000 = no timer; 600-900 seconds.
VERIFY=30	Alarm Verification Timer	00 = no timer; 00-30 seconds.
USA TIME	Time and date display format	USA TIME or EUR TIME
TERM=N	Terminal supervision	YES – To supervise the wiring of an FDU-80. NO – No FDU-80 supervision.
AC_DLY=N	Delays AC loss reporting	YES - AC loss reporting is delayed for approximately 3 hours. NO - No AC loss delay.
LocT	One of three operating modes of a PC or terminal connected to the control panel (through TB12 PC Terminal)	LocT – terminal connected to control panel and located in the same room as the control panel. LocM – terminal connected to control panel but requires password for operation. RemT – terminal connected through a modem for Read Status operations only.

Table 4.1 System Function Parameters (1 of 2)

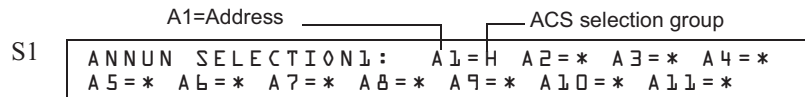
Parameter	Description	Settings
BLINK=01	The rate at which intelligent control or monitor modules blink during polling	BLINK=00: No blink BLINK=01: Devices blink on every poll. BLINK=16: Devices blink every 16th poll.
ST=4	NFPA wiring style operation for the SLC	4 – Style 4 SLC or 6 – both Style 6 and Style 7 SLC
ACS=N	Use ACS Selection Groups	N – No annunciator selected or Y – Select and display ACS Selection Groups

**Table 4.1 System Function Parameters (2 of 2)**

**How to Read Status for Annunciator Selections**

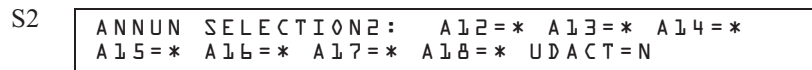


Annunciator Selection screens specify the information that displays on ACS annunciators. From the “Read Status” screen, press **0**, then press the ENTER key. You can now view Read Status for System Functions as follows: press **Z**, enter **S**, enter annunciation selection number (1-4 for annunciator, 5-8 for other settings), press the ENTER key. Sample LCD displays for the Read Status of Annunciator Selection are shown below:



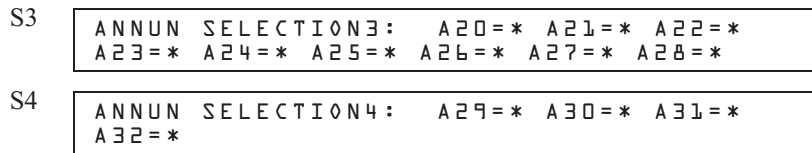
**Figure 4.7 Annunciator Selection 1 Screen**

To view the next three annunciator selection screens, press the **+** (NEXT SELECTION) key.



**Figure 4.8 Annunciator Selection 2 Screen**

If UDACT=N, the control panel displays the Annunciator Selections 3 and 4 screen, addresses A20-A32, as shown below:



**Figure 4.9 Annunciator Selections 3 and 4 Screens**

See page 42 and 43 of the NFS2 640 Programming Manual.



**Figure 4.10 System Function Selection 5 Screen**

See page 44 of the NFS2 640 Programming Manual.

S6

FLASHSCAN	LIDET	LIMOD	LZDET	LZMOD
	Y	Y	Y	Y

**Figure 4.11 System Function Selection 6 Screen**

See Page 42 of the NFS2 640 Programming Manual .

S7

NODE: 000.XXX, STYLE?:N
THRESHOLD CHANNEL A:H, CHANNEL B:H

**Figure 4.12 System Function Selection 7 Screen**

- SEC\_RLY and SUP\_RLY (0= turn on by Fire Alarm, 1= turn on by Security, 2= turn on by Supervisory).
- BAT\_SIZE (1= battery size is greater than 26 Ahr, 0= less than 26 Ahr).
- C\_DRILL (custom drill N= No custom drill, Y= Yes).
- TERM\_DATA (0= LCD80 Terminal using 7 bit data, 1= LCD80 Terminal using 8 bit data).
- PRT\_BAND (0= 2400, 1= 4800, 2= 9600).

S8

SEC_RLY:1	SUP_RLY:2	BAT_SIZE:0	C_DRILL:N
TERM_DATA:0	PRT_BAUD:2	CHARGER:Y	

**Figure 4.13 System Function Selection 8 Screen**

**NOTE:** Please refer to the Verifire Tools help file for information on programming the above screen.

An Annunciator Selection screen shows the information that will display on the ACS annunciators.

1 through 9	Programmable Annunciator #1 through #9
0	Programmable Annunciator #10
A	8 Systems points + Zones 1-56
B	Zones 57-99, 9 F zones, 8 R zones, 4NAC
C	Loop 1, Modules 1-64
D	Loop 2, Modules 1-64
E	Loop 1, Modules 65-128
F	Loop 2, Modules 65-128
G	Loop 1, Modules 129-159 & Loop 2, Modules 129-159
H	Loop 1, Detectors 1-64
I	Loop 2, Detectors 1-64
J	Loop 1, Detectors 65-128
K	Loop 2, Detectors 65-128
L	Loop 1, Detectors 129-159 & Loop 2, Detectors 129-159
M	Not Used
N	8 Systems points + Zones 1-56, used for remote station communicator (TM-4)
O	8 Systems points + Zones 1-56, used for municipal box trip output (TM-4)

Annunciator addresses 1 to 19 can be programmed to any one of the above selections. If there is a UDACT, selections A-M will be sent to Annunciator addresses 20 to 32 respectively.

**Table 4.2 ACS Selection Groups (2 of 2)**

The table above contains the ACS display selections. Annunciators set to annunciator address 1 to 19 can be programmed to any one of the above selections. If there is a UDACT, selections A-M will be sent to Annunciator addresses 20 to 32 respectively.

An example of ACS selections in Annunciator Selection Screen 1:

```
ANNUN SELECTION:  A1=H  A2=C  A3=*  A4=*
                   A5=*  A6=*  A7=*  A8=*  A9=*  A10=*  A11=*
```

**Figure 4.14 Annunciator Selection Screen 1 Example**

---

**NOTE:** An ACS selection marked with an asterisk (\*) indicates no annunciator selection.

---

The figure above shows annunciator selections for addresses A1-A2 (addresses A3-A10, marked with asterisks, are not selected).

- Annunciators set to annunciator address 1 (A1) display the status of detectors 1-64 on SLC 1 (ACS Selection Group H)
- Annunciators set to annunciator address 2 (A2) display the status of intelligent modules 1-64 on SLC-1 (ACS Selection Group C).

### How to Read Status for Battery Levels

Pressing the BATTERY LEVEL key on the NFS2-640 keyboard displays information concerning the state of the battery.

A sample LCD display is shown below.

```
Battery Voltage: 27.48V
Charger Current: 00.06A
```

**Figure 4.15 Battery Levels**

## 4.4.2 How to View Read Status for Event and Alarm History

### Overview

The control panel maintains a History buffer of the last 800 events, each with a time and date stamp. History events include the following:

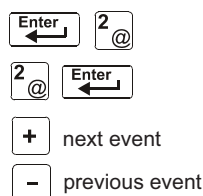
- All alarms, troubles and operator actions, such as: Acknowledge, System Reset, Signal Silence, Drill, and Walk Test.
- Programming entries (Program Change and Status Change, but not Read Status), along with a number (0-9) indicating the programming submenu (for example, 0=Clear). For an example, see Figure 4.18.

You can view events from the History buffer in two forms: by displaying all events (option 2, HIST=2) or by displaying alarm events only (option 4, ALARM HIST=4).

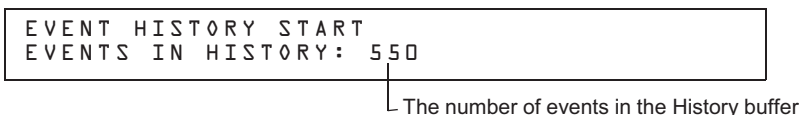


**NOTE:** The History buffer contains 800 events total, including the alarm events that display for Alarm history. The control panel generates Alarm history from the alarm events that exist in the 800-event History buffer.

### How to View Read Status for Event History



Option 2 (HIST=2) lets you view the total number of events in the History buffer (up to 800 events), then view each event in chronological sequence. From the “Read Status” screen, press 2, then press the ENTER key to display the “Event History” screen. A sample of the Event History screen is shown below:



**Figure 4.16 Sample Event History Display**

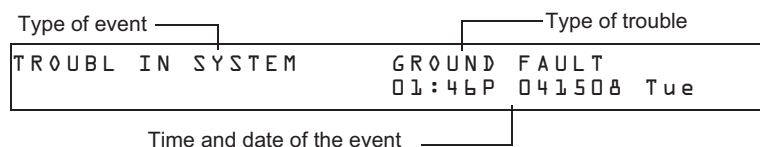
To display events in the History buffer, do the following:

- Press the NEXT SELECTION key to step through each event from the first entry (oldest event first) in the History buffer, or
- Press the PREVIOUS SELECTION key to step through each event from the most recent entry in the History buffer.



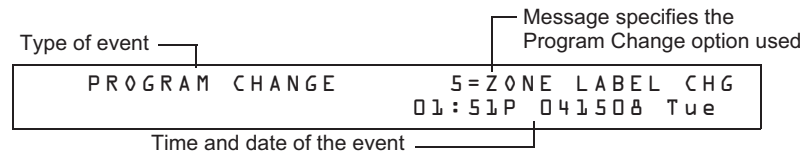
**NOTE:** The NEXT SELECTION key will show the most recent event first, and then move to its normal function of displaying the oldest events first.

A sample LCD display for a trouble event:



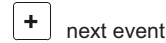
**Figure 4.17 Sample Trouble Event Display**

A sample LCD display for a Program Change event:

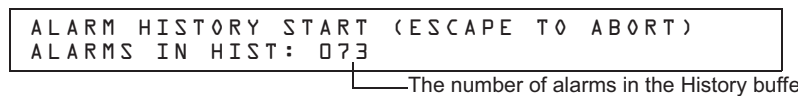


**Figure 4.18 Sample Program Change Event Display**

## How to View Read Status for Alarm History



Option 4 (ALARM HIST=4) lets you view the total number of alarms in the History buffer (up to 200), then view each alarm in chronological sequence. From the “Read Status” screen, press **4**, then press the ENTER key to display the “Event History” screen. A sample Alarm History screen is shown below:



**Figure 4.19 Sample Alarm History Display**

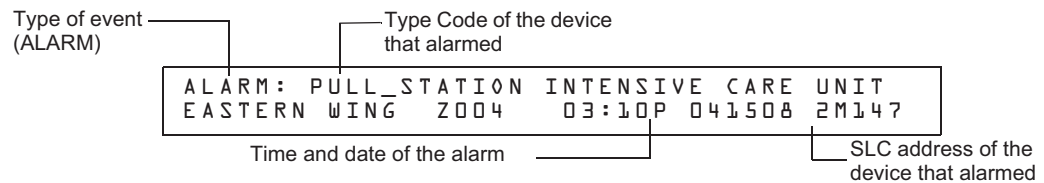
To display alarms in the buffer, do the following:

- Press the NEXT SELECTION key to step through each alarm from the first entry (oldest alarm first) in the buffer, or
- Press the PREVIOUS SELECTION key to step through each alarm from the most recent entry in the buffer



**NOTE:** The NEXT SELECTION key will show the most recent event first, and then move to its normal function of displaying the oldest events first.

A sample display for an alarm event:



**Figure 4.20 Sample Alarm Event Display**

## 4.4.3 How to Print Points, Event and Alarm History

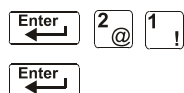
### Overview

Read Point options 1, 3, and 5 in the “Read Status” screen let you print points, event history, and alarm history. This section contains instructions for printing, as well as sample point, event history, and alarm history printouts.



**NOTE:** Before printing, make sure your control panel is connected to a compatible printer and the printer is configured according to the manufacturer’s specifications, and that the correct baud rate is selected at the panel.

## How to Print Points



Option 1 (PRNT POINT=1) lets you print a list of all points programmed into the system. From the “Read Status” screen, press **1**, then press the ENTER key to print a list of installed points. A sample Print Point screen is shown below:

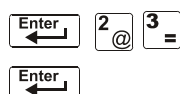
```
STATUS PRINT
```

**Figure 4.21 Sample Print Point Display**

A sample printout of three points using the Print Point option:

```
NORMAL SMOKE (PHOTO) DETECTOR ADDR 1D043      Z003 000%A8 8 ** 1D043
NORMAL SMOKE (PHOTO) DETECTOR ADDR 1D044      Z003 000%A8 8 ** 1D044
NORMAL SMOKE (PHOTO) DETECTOR ADDR 1D045      Z003 000%A8 8 ** 1D045
```

## How to Print Event History



Option 3 (HIST=3) lets you print a list of all events in the History buffer (up to 800). From the “Read Status” screen, press **3**, then press the ENTER key to print a list of events. A sample History Print screen is shown below:

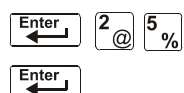
```
HISTORY PRINT
```

**Figure 4.22 Sample History Print Screen**

A sample printout of three events in history using the History Print option:

```
***** EVENT HISTORY START*****
SYSTEM RESET                                02:28P 042408 Thu
ALARM: SMOKE (ION) DETECTOR ADDR 1D075      Z002 02:28P 042408 1D075
ALARM: SMOKE (ION) DETECTOR ADDR 1D076      Z002 02:28P 042408 1D076
ACKNOWLEDGE                                02:28P 042408 Thu
```

## How to Print Alarm History



Option 5 (ALARM HIST=5) lets you print a list of alarm events in the History buffer (up to 200). From the “Read Status” screen, press **5**, then press the ENTER key to print a list of alarm events. A sample Print Alarm History screen is shown below:

```
ALARM HISTORY PRINT
```

**Figure 4.23 Sample Print Alarm History Display**

A sample printout of two alarm events in the History buffer using the Print Alarm History option.

```
*****ALARM HISTORY START*****
ALARM: SMOKE (ION) DETECTOR ADDR 1D075      Z002 02:28P 012208 1D075
ALARM: SMOKE (ION) DETECTOR ADDR 1D076      Z002 02:28P 012208 1D076
*****
PRINT END *****
```



#### 4.4.4 How to View and Print Hidden Event and Alarm History

The control panel maintains a copy of the History buffer. For instance, if someone clears the History buffer using Status Change programming option 4, the control panel retains a copy of the History buffer. The copy of the preceding History buffer is called a Hidden History buffer and a copy of the preceding Alarm History is called a Hidden Alarm History buffer.

If you attempt to view or print history and the control panel displays one of the screens shown below you can use the options listed in the table below to view the contents of a Hidden History buffer.









```
HISTORY EMPTY      (ESCAPE TO ABORT)
*****
```

**Figure 4.24 History Empty Display**

```
ALARM HISTORY EMPTY (ESCAPE TO ABORT)
*****
```

**Figure 4.25 Alarm History Empty Display**

Options for viewing and printing Hidden History and Hidden Alarm History do not appear in the LCD display when in Read Status. You can view and print the contents of these Hidden History buffers using the options listed in the table below. You read and print Hidden History and Hidden Alarm History the same way you read and print history using the options that appear on the “Read Status” screen. The table also contains references to the sections that contain instructions for reading and printing history.

To	Press	Refer to
Read Hidden Alarm History	 2 @ 6 : 	“How to View Read Status for Alarm History” on page 46
Print Hidden Alarm History	 2 @ 7 \ 	“How to Print Alarm History” on page 47
Read Hidden History	 2 @ 8 . 	“How to View Read Status for Event History” on page 45
Print Hidden History	 2 @ 9   	“How to Print Event History” on page 47

**Table 4.3 Hidden History Selections**

## Notes



# Appendix A: Special Zone Operation

## A.1 Overview

This section contains information for operating the control panel as detailed in the topics listed below:

Section	Special Zone	Refer to Page
A.2, "Releasing Zones (R0-R9)"	R0-R9	page 51
A.3, "Time, Date, and Holiday Functions"	F5, F6, F7	page 54
A.4, "NAC Coding"	F8	page 56
A.5, "Presignal and Positive Alarm Sequence (PAS) Operation"	F0	page 57

## A.2 Releasing Zones (R0-R9)

### A.2.1 Purpose of Releasing Zones



**WARNING:** When used for CO<sub>2</sub> releasing applications, observe proper precautions as stated in NFPA 12. Do not enter the protected space unless physical lockout and other safety procedures are fully completed.

Do not use software disable functions in the panel as lockout.

The control panel provides ten Releasing Zones (R0-R9). These are special zones that you can use for up to ten independent releasing operations. This section contains descriptions of each Releasing Function option and an example of how Releasing Zone options work.

For instructions on programming Releasing Functions, refer to the *NFS2-640 Programming Manual*.

Each Releasing Zone includes the following releasing options:

Option	Description
Cross Zone	Cross Zones let you program the control panel to activate a Releasing Zone when two or more detectors are alarmed. Cross Zone selections are: <b>Y</b> Two or more detectors are alarmed that are mapped to one of the ten Releasing Zones (R0-R9) <b>Z</b> Two or more detectors are alarmed that are mapped to two different Software Zones and mapped to one of the ten Releasing Zones (R0-R9). <b>H</b> At least one smoke detector mapped to one of the ten Releasing Zones (R0-R9) is alarmed <i>and</i> at least one heat detector mapped to the same Releasing Zone as the smoke detector is alarmed. <b>N</b> Cross Zones not used
Delay Timer	Select a 0–60 second delay before activating a zone.
Abort	An Abort Switch Type Code used to abort activation of a zone.
Manual Release	Allows immediate zone activation by overriding the abort function, cross-zone function, and delay timer.
Soak Timer	Automatically shuts off the releasing device after a preprogrammed period of time. Select 0001-9999 seconds for a Soak Timer or 0000 seconds for no Soak Timer.

**Table A.1 Releasing Options**

## A.2.2 How to View Releasing Zone Selections

You can use the Read Status Entry option to view the current selections for a Releasing Zone. For example, to view selections for Releasing Zone R1, press the keys in sequence:



A sample LCD display of a Releasing Function selected for Releasing Zone R1:

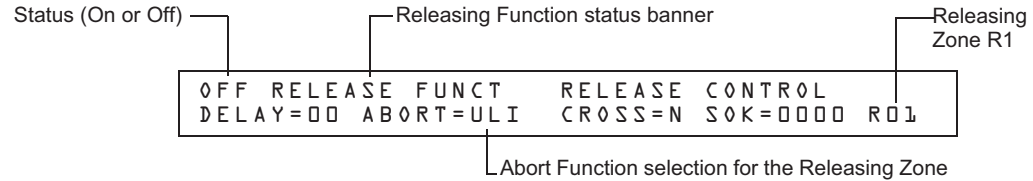
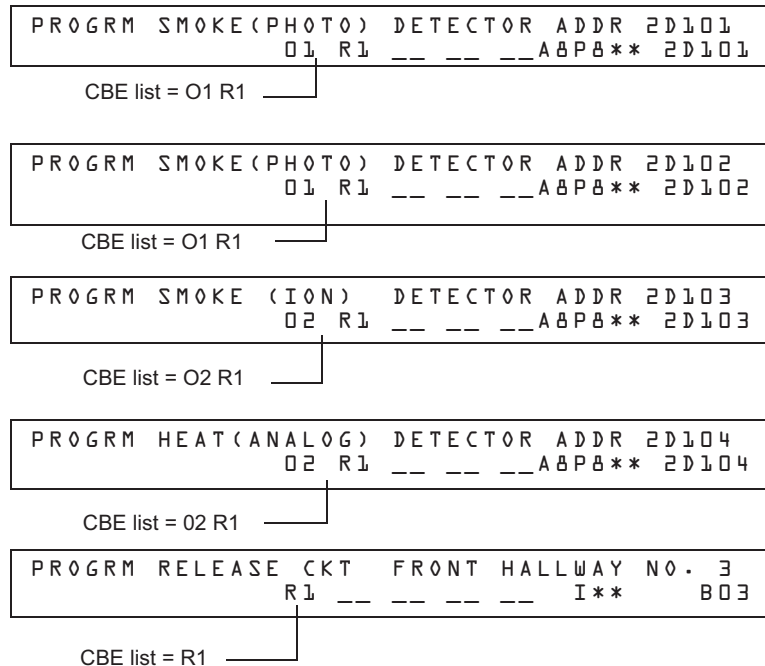
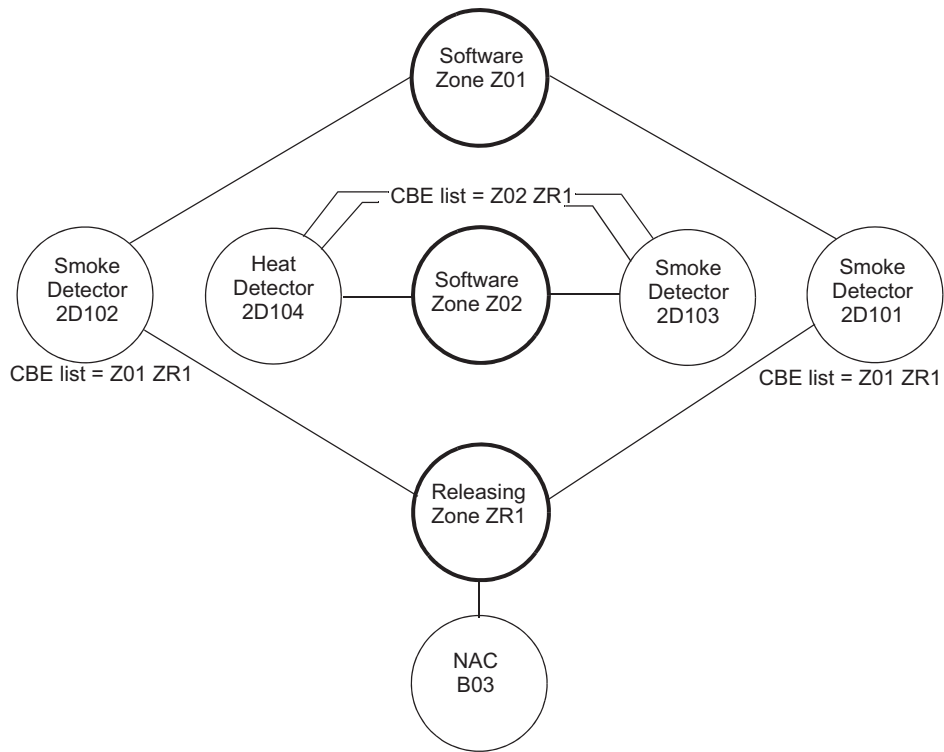


Figure A.1 Sample Read Status for a Releasing Zone

## A.2.3 How Releasing Zones Operate

The figure below contains an illustrated example of how Releasing Zones work, using cross zone selections with four detectors and a NAC mapped to Releasing Zone 1 (listed as ZR1 in the CBE list). Table A.2 lists the cross zone selections and the conditions that activate the Releasing Zone:





**Figure A.2 Illustrated Example of Cross Zone Programming**

Listing of each Cross Zone option and the conditions required to activate the Releasing Zone, according to the example shown in Figure A.2.

Cross Zone Selection (Cross=)	Condition(s) Required to Activate the Releasing zone
Cross=N	An alarm from any detector activates the releasing circuit.
Cross=Y	An alarm from any two detectors activates the releasing circuit.
Cross=Z	An alarm from two detectors mapped to different Software Zones, but mapped to the same Releasing Zone. <ul style="list-style-type: none"> <li>• An alarm from 2D101 and 2D103 – detectors mapped to different zones, but both list ZR1 in their CBE.</li> <li>• An alarm from 2D102 and 2D104 – detectors mapped to different zones, but both list ZR1 in their CBE.</li> <li>• An alarm from 2D101 and 2D104 – detectors mapped to different zones, but both list ZR1 in their CBE.</li> <li>• An alarm from 2D102 and 2D103 – detectors mapped to different zones, but both list ZR1 in their CBE.</li> </ul>
Cross=H	Activation of heat detector 2D104 and one smoke detector (2D101, 2D102, or 2D103).

**Table A.2 Example of Cross Zone Selections**

## A.3 Time, Date, and Holiday Functions

### A.3.1 Overview

The control panel includes a real-time clock that displays the time-of-day, the date, and the day-of-week. The clock includes a lithium battery backup. Time displays in a USA format (12-hour time format with month/day/year) or a EUR (European) format as shown below:

```

TROUBL CONTROL      MODULE ADDR 1M159
                OPEN      03:48P 041508 1M159
    
```

USA Time and Date format (default)

```

TROUBL CONTROL      MODULE ADDR 1M159
                OPEN      15:48 140408 1M159
    
```

EUR Time and date format

**Figure A.3 Sample USA and EUR Time/Date Formats**

The control panel also provides Time Control zones F5 and F6 for time and date control functions and zone F7 for holiday functions.

### A.3.2 How to View Time Control Selections

You can use the Read Status Entry option to view the current selection for the Time function. To do so, press the following keys in sequence:

2 @ 0 ?  Z F 5 %

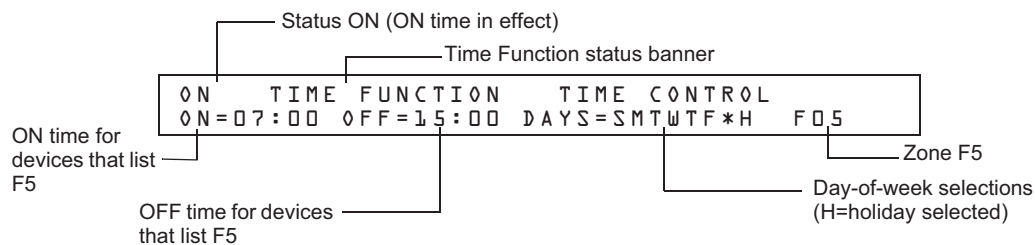
or

2 @ 0 ?  Z F 6 :



**NOTE:** For instructions on programming the Time function, refer to the *NFS2-640 Programming Manual*.

The LCD display shows the current selections for the Time Control function. The figure below shows a sample LCD display of a Time Control function:



**Figure A.4 Sample Read Status for Time Function**



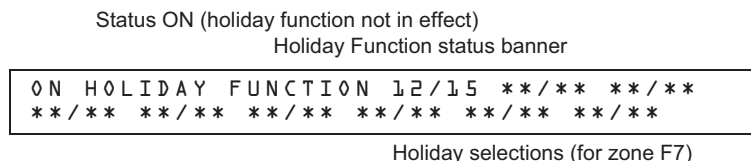
### A.3.3 How to View Holiday Function Selections

You can use the Read Status Entry option to view the current selection for the Holiday function. To do so, press the following keys in sequence:



**NOTE:** For instructions on programming the Holiday function, refer to the *NFS2-640 Programming Manual*.

The LCD display in Figure A.5 gives an example of an LCD display of a Holiday function:



**Figure A.5 Sample Read Status for Holiday Function**

### A.3.4 How Time Control and Holiday Functions Work

Time and Holiday activation occurs automatically and does not require operator intervention. All outputs with a CBE list containing F5 or F6 activate within the times specified for the days of the week listed in F5 or F6. All smoke detectors with a CBE list containing F5 or F6 switch to their lowest sensitivity (AL:9) within the times specified for the days of the week listed in ZF5 or ZF6. Refer to “Intelligent Sensing Applications” in the *NFS2-640 Programming Manual* for details on setting detector sensitivity.

Time Control is active for all days of the week listed in F5 or F6. Holidays listed in F7 are excluded unless you list Holidays (H) in the day-of-week selection of F5 and F6 (shown in Figure A.4). Enter the time functions in a 24-hour format with the OFF time later than the ON time. After changing programming using Time Control, always reset the control panel.



**NOTE:** You can turn a NON FIRE control point on and off, by listing zone F5 or F6 in the CBE list of a control/relay module.

You can use Time Control zones F5 and F6 to program non-fire applications such as turning lights on and off, setting a thermostat, and so on. For example, you can program zones F5 and F6 to activate outputs at one time of day and deactivate outputs at later time, on specified days of a week. Table A.3 contains descriptions of additional Time Control applications:

Application	Requirement
Control day and night sensitivity of intelligent, addressable detectors	List zone F5 or F6 in the detector CBE. This automatically sets the detector sensitivity to the minimum setting (AL:9) during the day and automatically returns detector sensitivity to programmed sensitivity during the evening.
Control a specific date of-year	Input up to nine date in the Holiday selection screen for Special Zone F7, then list zone F7 (Holiday) in the CBE of a device.

**Table A.3 Time Control Applications**

## A.4 NAC Coding

### A.4.1 Overview of Coding

A Coding selection is the Code Type that pulses when the control panel activates a NAC mapped to Special Zone F8. Special Zone F8 provides seven coding selections (see Table A.4) that you can list in the CBE of a NAC. To use a Code Type, program a NAC to list Zone F8 (reserved for a Code Type) in the NAC CBE list.



**NOTE:** Control modules (FCM-1, FRM-1) cannot be coded.

The table below contains descriptions of the signals that correspond to each NAC Code Type:

Coding Selection	Signal	Notes
March Time (default)	120 PPM (pulses Per minute)	Default selection for NACs mapped to F8.
Two-Stage	Alert signal (20 PPM) or General Alarm signal (Temporal pattern)	Alert signal – When an alarm occurs and not activated by another zone, the output pulses at 20 PPM. General Alarm signal – If not acknowledged within 5 minutes, the control panel switches from 20 PPM to Temporal pattern.
California	10 sec. On, 5 sec. Off, repeats	n/a
Temporal	0.5 on, 0.5 off, 0.5 on, 0.5 off, 0.5 on, 1.5 off, repeats	Used as a standard general EVAC signal.
Canadian Dual Stage (3 minutes)	Alert signal (20 PPM) Drill Switch activation switches to Temporal pattern	Same as Two-Stage except will only switch to second stage by activation of Drill Switch three minute timer.
Canadian Dual Stage (5 minutes)	Alert signal (20 PPM) Drill Switch activation switches to Temporal pattern	Same as Two-Stage except will only switch to second stage by activation of Drill Switch five minute timer.
System Sensor Strobe		Synchronizes System Sensor ADA horn/strobes.

**Table A.4 F8 Code Types and Audio Signals**

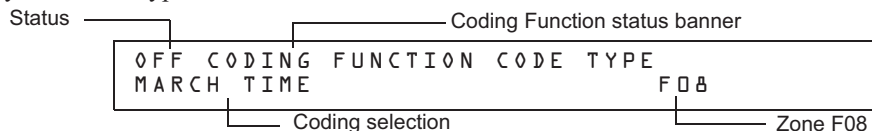
### A.4.2 How to View Coding (F8) Selections

You can use the Read Status Entry option to view the current selection for the Coding function. To do so, press the following keys in sequence:



**NOTE:** For instructions on programming the Coding function, refer to the *NFS2-640 Programming Manual*.

The LCD display shows the current selections for the Code Type. Figure A.6 shows a sample LCD display of a Code Type selection of March Time:



**Figure A.6 Sample Read Status for Coding Function**

### A.4.3 How to Respond to an Alarm with Coding

If an alarm occurs with a Coding selection, the control panel latches the control panel in alarm and pulses outputs mapped to F8 at the pulse specified by the Coding selection (see Table A.4). To silence the outputs, press the SIGNAL SILENCE key.

## A.5 Presignal and Positive Alarm Sequence (PAS) Operation

### A.5.1 Overview

This section describes the Presignal and PAS selection, and provides instructions on how to do the following:

- View Presignal and PAS selections
- Respond to an alarm with Presignal
- Operate the control panel with a Presignal Delay Timer only
- Operate the control panel with a Presignal Delay Timer and PAS

### A.5.2 What is Presignal and PAS?

Presignal is a feature that initially causes alarm signals to only sound in specific areas, monitored by qualified persons. This allows delay of the alarm from 60 to 180 seconds after the start of alarm processing. The control panel Presignal feature provides two selections:



**NOTE:** Presignal differs from the Alarm Verification Timer which does not require human intervention.

- A Presignal Delay Timer (60-180 seconds) that delays activation of all outputs with a CBE that includes Special Zone F0.
- A PAS selection, in addition to the Presignal Delay Timer, that allows a 15-second time period for acknowledging an alarm signal from a fire detection/initiating device. If the alarm is not acknowledged within 15 seconds, all local and remote outputs activate immediately and automatically.

An illustration of Presignal and PAS timing.

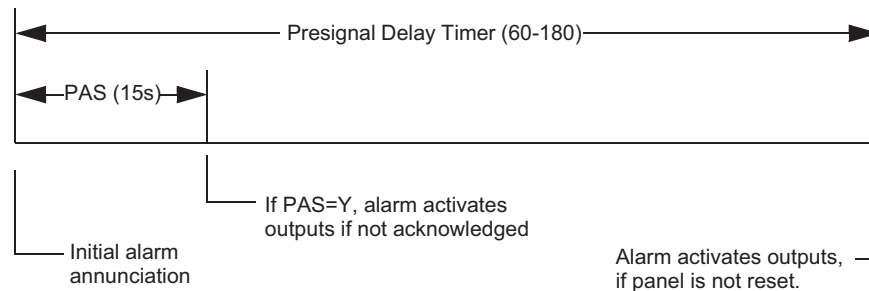


Figure A.7 Presignal and PAS Time

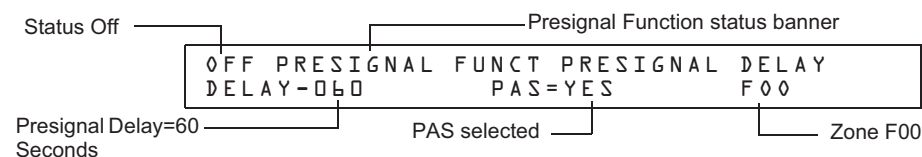
### A.5.3 How to View Presignal and PAS Selections

You can use the Read Status Entry option to view the current selection for the Presignal function. To do so, press the keys in sequence:



**NOTE:** For instructions on programming the Presignal function, refer to the *NFS2-640 Programming Manual*.

The LCD display shows the current selections for the Presignal function. The figure below shows a sample LCD display of a Presignal function selected for PAS and a Presignal Delay Timer of 60 seconds:



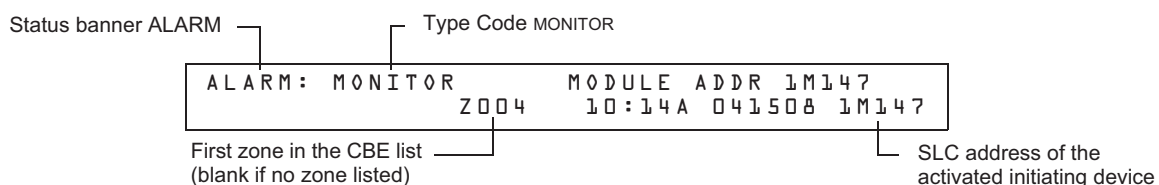
**Figure A.8 Sample Read Status for Presignal Function**



**NOTE:** If any monitor modules are programmed with a PAS INHIBIT Type Code and a fire alarm occurs, zone F0 goes false and aborts the Presignal Delay Timer.

### A.5.4 How to Respond to an Alarm with Presignal Delay Timer (no PAS)

If an alarm occurs with a Presignal Delay Timer (60-180 seconds), the control panel displays the type of device and the SLC address of the device causing the alarm. If a second alarm occurs during the Presignal Delay Timer, the control panel aborts the Presignal Delay Timer and activates all programmed outputs. A sample Alarm screen for a monitor module is shown below:



**Figure A.9 Sample Alarm Display Screen**

The FIRE ALARM LED flashes and the panel sounder pulses a steady tone. The control panel latches until the alarm is corrected and you press the SYSTEM RESET key to reset the control panel. You have the duration of the Presignal Delay Timer (60-180 seconds) to respond to the alarm before the control panel automatically activates all outputs programmed to F0. You can take the following actions:

- To silence the panel sounder and change the FIRE ALARM LED from flashing to steady, press the ACKNOWLEDGE/SCROLL DISPLAY key.
- To abort the Presignal Delay Timer, press the SYSTEM RESET key.
- To manually activate all outputs programmed to F0, press the DRILL key. The Manual Evacuate screen appears, the panel sounder pulses and the FIRE ALARM LED changes from flashing to steady. The Manual Evacuate screen and Alarm screen display alternately at 3-second intervals.

If the Presignal Delay Timer reaches its programmed value, without operator intervention, the control panel activates all outputs programmed to F0.

## A.5.5 How to Respond to an Alarm with Presignal Delay Timer (PAS selected)

If an alarm occurs with a Presignal Delay Timer (60-180 seconds) and PAS selected, the control panel displays an Alarm screen that shows the type of device and the SLC address of the device causing the alarm. When an alarm comes from an initiating device with a CBE list that includes F0 (with PAS selected), the control panel delays the following outputs:

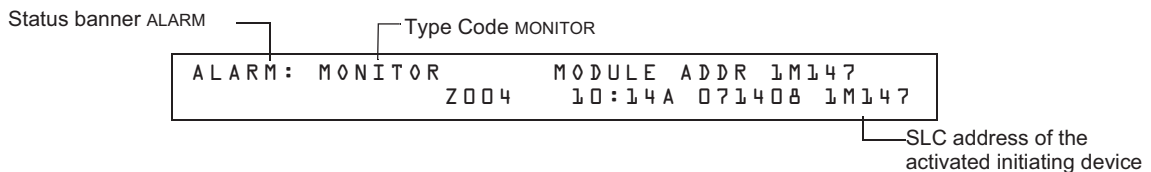
- System Alarm relay
- TM-4 Polarity Reversal Alarm output
- TM-4 Municipal Box output



**NOTE:** These outputs do not delay for Presignal operations without PAS selected.

If a second alarm occurs during the Presignal Delay Timer, the control panel aborts the Presignal Delay Timer and activates all programmed outputs.

A sample Alarm screen for a monitor module:



**Figure A.10 Sample Alarm Display Screen**

The FIRE ALARM LED flashes and the panel sounder pulses a steady tone. The control panel latches until the alarm is corrected and you press the SYSTEM RESET key to reset the control panel. You have 15 seconds to acknowledge the alarm or the control panel automatically activates all outputs programmed to F0. If you acknowledge the alarm within 15 seconds, the control panel increases the delay time to the full Presignal Delay Timer (60-180 seconds). You have the duration of the Presignal Delay Timer to respond to the alarm before the control panel activates all outputs programmed to F0. You can take the following actions:

- To increase the delay to the full programmed Presignal Delay Timer, press the ACKNOWLEDGE/SCROLL DISPLAY key. The panel sounder goes silent and the FIRE ALARM LED changes from flashing to steady.
- To abort the Presignal Delay Timer, press the SYSTEM RESET key.
- To manually activate all outputs programmed to F0, press the DRILL key. The Manual Evacuate screen appears, the panel sounder pulses and the FIRE ALARM LED changes from flashing to steady. The Manual Evacuate screen and Alarm screen display alternately at 3-second intervals.

If the Presignal Delay Timer reaches its programmed value, without operator intervention, the control panel activates all outputs programmed to F0.



# Appendix B: Intelligent Detector Functions



**NOTE:** For instructions on selecting Intelligent Detector Functions, refer to the *NFS2-640 Programming Manual*.

## Descriptions for Intelligent Detector Functions

Function	Description
Analog Display	The control panel reads and displays analog information from the 318 analog detectors (159 per SLC). The display shows the sensed air at the detector as a percentage of the alarm threshold for each detector.
Sensitivity Adjust	Nine selections for manually setting intelligent detector alarm levels within the UL range. <i>If using ionization detectors in duct applications, set Sensitivity Adjust to Level 1.</i> Refer to the <i>NFS2-640 Programming Manual</i> for detector sensitivity information.
Day/Night Sensitivity Operation	You can program the system to automatically force smoke detectors to minimum sensitivity during the day. Refer to "Time, Date, and Holiday Functions" on page 54.
Maintenance Alert	When compensation reaches the limit of the amount of drift compensation that can be safely applied, the control panel reports a trouble condition, according to National Fire Alarm Code standards. This condition also activates if the detector remains at very high or very low measured air levels for an extended time.
Automatic Test Operation	The control panel performs an automatic test of each detector every 256 minutes. Failure to meet the test limits causes an Auto Test Fail trouble.
Type Code Supervision	The control panel monitors hardware device Type Codes for each installed device at regular intervals (an interval can take up to 40 minutes for a full capacity system). If a mismatch of type compared to the program occurs, the control panel generates a point trouble labeled Invalid Type.
LED Control Operation	A global program selection to prevent detector LEDs from blinking as a result of polling during normal operation. A typical application is a sleeping area where a blinking light can distract people. As a standard function, independent of this programming selection, the control panel allows all LEDs to turn on in alarm.
Alarm Verification Timer and Verification Counter Operation	The control panel performs alarm verification on programmed intelligent smoke detectors. The Alarm Verification Timer is a global program selection of 0–60 seconds (ULC installations can not exceed 30 seconds). Each detector includes a Verification Counter, which displays the number of times that a detector entered verification but did not time-out to alarm. The Verification Counter increments to 99 and holds.

**Table B.1 Intelligent Detector Functions**



## Notes

# Appendix C: Remote Terminal Access

## C.1 General Description

The control panel can communicate with a remote terminal or computer connected to the EIA-232 PC/Terminal port. Refer to the *NFS2-640 Installation Manual* for installation information.



---

**NOTE:** See the *NFS2-640 Programming Manual* for instructions on enabling the CRT.

---

This port may be set up for interactive operation or for monitoring only. Interactive operation requires that all equipment be UL-listed under UL Standard for Safety UL 864 and be installed and set up as directed under Local Terminal Mode (LocT) or Local Monitor Mode (LocM).

ITE (Information Technology Equipment) equipment listed under UL 1950 is allowed for ancillary system monitoring when the system is installed and set up as directed under Remote Terminal Mode (RemT).

## C.2 Operating Modes

The control panel provides three operating modes for the CPU EIA-232 PC/Terminal port:

- Local Terminal - LocT
- Local Monitor - LocM
- Remote Monitor - RemM

You select the operating mode during control panel programming (Global System Functions). For more information, refer to the *NFS2-640 Programming Manual*.

The following subsections outline the functions, password requirements, and additional information for each operating mode.

### C.2.1 Local Terminal Mode (LocT)

Functions, passwords, and special requirements of Local Terminal Mode (LocT) are:

<b>Functions:</b>	Read Status, Alter Status, and Control Functions (Table C.1).
<b>Passwords:</b>	User-defined password for Alter Status functions.
<b>Requirements:</b>	The terminal must be mounted in a UL 864 listed enclosure or positioned to provide equivalent protection against unauthorized use.

Functions available with the Local Terminal Mode:

Function	Lets you...
Read Status	<ul style="list-style-type: none"><li>• Display the status of an individual point (Detector, Module, or Zone).</li><li>• Display a list of all the points in Alarm or trouble.</li><li>• Display a list of all programmed points in the system.</li><li>• Step through the History buffer event by event.</li><li>• Display the entire History buffer.</li><li>• Step through Alarm History</li><li>• Display the entire Alarm History</li></ul>

**Table C.1 Local Terminal Mode Functions (1 of 2)**

Function	Lets you...
Alter Status	<ul style="list-style-type: none"> <li>• Disable/Enable an individual point.</li> <li>• Change the sensitivity of a detector.</li> <li>• Clear the verification counter of all detectors.</li> <li>• Clear the entire History buffer.</li> <li>• Set the Intelligent Sensing alert and action levels.</li> </ul>
Control Functions	<ul style="list-style-type: none"> <li>• Acknowledge.</li> <li>• Signal Silence.</li> <li>• System Reset.</li> <li>• Drill.</li> </ul>

**Table C.1 Local Terminal Mode Functions (2 of 2)**

## C.2.2 Local Monitor Mode (LocM)

Functions, passwords, and special requirements of Local Monitor Mode (LocM) are:

- Functions:** Read Status, Alter Status, and Control Functions (Table C.2).
- Passwords:** User-defined password for Alter Status and Control functions.
- Requirements:** Password security feature for Control Functions eliminates the need for mounting the CRT-2 in an enclosure.

Functions available with the Local Monitor Mode:

Function	Lets you...
Read Status	<ul style="list-style-type: none"> <li>• Display the status of an individual point (Detector, Module, or Zone).</li> <li>• Display a list of all the points in Alarm or trouble.</li> <li>• Display a list of all programmed points in the system.</li> <li>• Step through the History buffer event by event.</li> <li>• Display the entire History buffer.</li> <li>• Step through Alarm History</li> <li>• Display the entire Alarm History</li> </ul>
Alter Status	<ul style="list-style-type: none"> <li>• Disable/Enable an individual point.</li> <li>• Change the sensitivity of a detector.</li> <li>• Clear the verification counter of all detectors.</li> <li>• Clear the entire History buffer.</li> <li>• Set the Intelligent Sensing alert and action levels.</li> </ul>
Control Functions	<ul style="list-style-type: none"> <li>• Acknowledge</li> <li>• Signal Silence</li> <li>• System Reset</li> <li>• Drill</li> </ul>

**Table C.2 Local Monitor Mode Functions**

## C.2.3 Remote Terminal Mode (RemT)

Functions, passwords, and special requirements of Remote Terminal Mode (RemT) are:

- Functions:** Read Status only. See Table C.3.
- Passwords:** None
- Requirements:** Use with UL ITE-listed terminals, including personal computers with the VeriFire™ Tools or terminal emulation software. Intended for terminals connected through modems, including FSK modems connected through a public switched telephone network.

Functions available with the Remote Terminal Mode:

Functions	Lets you...
Read Status	<ul style="list-style-type: none"> <li>• Display the status of an individual point (Detector, Module, or Zone).</li> <li>• Display a list of all the points in Alarm or trouble.</li> <li>• Display a list of all programmed points in the system.</li> <li>• Step through the History buffer event by event.</li> <li>• Display the entire History buffer.</li> <li>• Step through Alarm History</li> <li>• Display the entire Alarm History</li> </ul>
Alter Status	• N/A
Control Functions	• N/A

**Table C.3 Remote Terminal Mode Functions**

## C.3 Using the CRT-2 for Read Status

### C.3.1 Overview

This section shows how to perform Read Status functions from a CRT-2.



**NOTE:** See the *NFS2-640 Programming Manual* for instructions on enabling the CRT port.

For more information see the “Read Status” section of this manual.

Function	Lets you...
Read Point	Read the status of any point in the system (detectors, modules, software zones, and system parameters).
Alm/Tbl Status	Display a list of all devices in the system that are in Alarm or trouble.
Read All Points	Display a list of all points programmed in the system. This list will display the status of all addressable detectors, modules, system parameters and software zones.
History Step	Step through the History buffer one event at a time.
History All	Send the entire History buffer to the CRT, from the most recent event to the oldest event.
Alarm History Step	Step through Alarm History one alarm at a time.
Alarm History All	Display a history list of all alarms.

**Table C.4 Read Status Functions**

### C.3.2 Accessing Read Status Options

Access the Read Status function from the CRT-2 by following these steps.

1. Turn on the CRT-2, which is connected to the control panel.
2. Press the Read Status function key. The control panel displays the “Read Status” menu options:

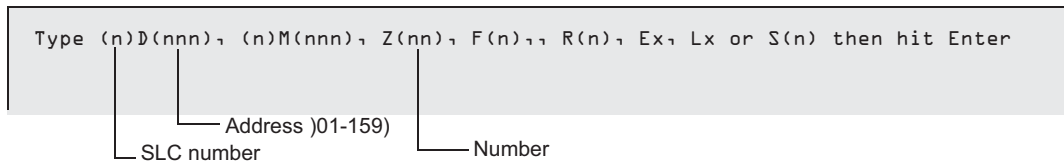
```
Rd Point=1, Rd Alm/Tbl=2, All Points=3, Hist:Step=4/All=5, Ala-Hist:Step=6/All=7
```

From the Read Status menu, you can select options 1-7.

### C.3.3 Read Point

From the Read Status menu, select option **1** - Read Point. The CRT-2 displays the following:

Press <1> <ENTER>



Enter the following:

1. Enter the SLC number "1" or "2".



**NOTE:** Press **F5** to scroll forward through a list of devices. Press **F6** to scroll back through a list of devices.

2. Enter the first letter of the device, using upper case letters.
  - Detector = "D"
  - Module = "M"
  - Zone = "Z"
  - Special Function = "F"
  - Releasing Zone = "R"
  - E Zone = "E"
  - L Zone = "L"
  - System Parameter = "S"
3. Enter the address or number of the device.
4. Press "ENTER".

**Example** Read points for detectors 1D001 and 1D002 on SLC 1:

Press <1> <D> <0> <0> <1> <ENTER>

```
NORMAL SMOKE (PHOTO) INTENSIVE CARE UNIT NURSE LOUNGE Z050 020%AB 6 CV30 1D001
```

Press <NEXT>

```
NORMAL SMOKE (ION) DETECTOR ADDR 1D002 Z002 000%AB 6 ** 1D002
```

### C.3.4 Display Devices in Alarm or Trouble

From the "Read Status" menu, select option **2** - Read Alarms/Troubles. The CRT-2 will display the alarm and trouble history.

The semicolon, a control character in networking applications, separates the hour and minute of events displayed from history. If events display as they occur, a colon separates the hour and minute.

Press <2> <ENTER>

```

TROUBL SMOKE(PHOTO) DETECTOR ADDR 1D003      INVREP 01:09P 041608 1D003
TROUBL SMOKE (ION) DETECTOR ADDR 1D004      INVREP 01:09P 041608 1D004
TROUBL HEAT(FIXED) DETECTOR ADDR 1D006      INVREP 01:09P 041608 1D006
TROUBL MONITOR      MODULE ADDR 1M041      INVREP 01:09P 041608 1M041
TROUBL IN SYSTEM    GROUND FAULT          01:09P 041608 Wed
TROUBL IN SYSTEM    BATTERY              01:09P 041608 Wed
  
```

Semicolon

### C.3.5 Display All Programmed Points

From the “Read Status” menu, select option 3 - All Points. This option lets you view the status of all addressable detectors, modules, system parameters, and software zones.

```

NORMAL SMOKE(PHOTO) DETECTOR ADDR 1D002      Z003  000%A8 8 ** 1D002
NORMAL SMOKE (ION) DETECTOR ADDR 1D003      Z002  020%A6 6 ** 1D003
NORMAL HEAT(FIXED) DETECTOR ADDR 1D006      Z001  050%  * 1D006
NORMAL SMOKE(LASER) DETECTOR ADDR 1D099      Z004  000%A6 6 *V00 1D099
OFF     RELEASE CKT  MODULE ADDR 1M001      ZR00  *  I** 1M001
NORMAL MONITOR      MODULE ADDR 1M001      ZR00  *  I** 1M001
OFF     RELAY        MODULE ADDR 1M033      Z000  *  *FW 1M033
OFF     SOFTWARE ZONE Zone 01                Z01
  
```

### C.3.6 Step-through History

From the “Read Status” menu, select option 4 - Step-through History. This option lets you step through all history events one at a time.

### C.3.7 View All History

From the “Read Status” menu, select option 5 - History ALL. The entire history of events will display on the screen.

### C.3.8 Step-through Alarm History

From the “Read Status” menu, select option 6 - Step-through Alarm History. This option lets you step through the panel’s alarm history one event at a time.

### C.3.9 View All Alarm History

From the “Read Status” menu, select option 7 - Alarm History All. The entire history of alarm events will display on the screen, from most recent to oldest.

Press <6> <ENTER>

```

***** EVENT HISTORY START *****
ALARM: MAN_RELEASE MODULE ADDR 1M065      10:21A 041508 1M065
ALARM: MAN_RELEASE MODULE ADDR 1M065      10:19A 041508 1M065
ALARM: MAN_RELEASE MODULE ADDR 1M065      03:20P 041408 1M065
ALARM: SMOKE (ION) DETECTOR ADDR 1D129      03:20P 041408 1M065
  
```

Step through the Alarm History buffer one event at a time by pressing the Next **F5** or Prior **F6** function keys.

## C.4 Using the CRT-2 for Alter Status

### C.4.1 Overview

This section shows how to Alter Status functions from a CRT-2.



**NOTE:** The panel must be in Local Terminal Mode (LocT) or Local Monitor Mode (LocM).



**NOTE:** See the *NFS2-640 Programming Manual* for instructions on enabling the CRT port.

Function	Lets you...
Disable	Enable or disable detectors or modules.
Alarm/Pre-Alarm	Change the Alarm and Pre-Alarm levels of any addressable detector in the system.
Clear Verification	Clear the verification counter for all the addressable detectors in the system.
Clear History	Clear the contents of the History buffer.
Set Action/Alert	Set the Pre-Alarm for Alert or Action.

**Table C.5 Alter Status Functions**

### C.4.2 Accessing Alter Status Options

Access **Alter Status** function from the CRT-2 by following these steps.

1. Turn on the CRT-2 connected to the control panel.
2. Press the Alter Status function key. The control panel displays the Password screen.

Press <ALTER STATUS>

```
Enter Status CHange Password or Escape to Abort
```

3. Enter the Status Change Password. The factory default Status Change Password is 11111. The password does not display on the CRT-2. Five asterisks will appear in place of the password.

Press <1><1><1><1><1><ENTER>

```
*****
```

The Alter Status Options menu appears.

```
1=Disable 2=Alarm/Prealarm 3=Clear Verification 4=Clear History 5=Alert/Action
```

From the Alter Status Options menu, you can select **1-5**.



### C.4.3 Enable or Disable Detectors, Modules or Zones

From the “Alter Status” menu select option **1** - Disable. Disable lets you enable or disable detectors, modules, or zones.

```

Press <1><ENTER>
┌── SLC Number
│   └── Address (01-159)
└──
Disable/Enable. Type nD(nnn) / nMnnn / P(nn) / Z(nn) then Enter
STATUS CHANGE          Dis/Ena point                               08:29A Tue 04/15/08
└── Number

```

Enter the following:

1. Enter the SLC loop number **1** or **2**.
2. Enter the first letter to read one of the following, using upper case letters:
3. Detector = **D**  
Module = **M**  
NAC = **P**  
Zone - **Z**
4. Enter the address or number of the device.
5. Press ENTER and a display similar to the following will appear.

EXAMPLE Disable Detector address 101 on SLC1:

Press <1><D><1><0><1><ENTER>

```
D101 Now Enabled, Enter E(Enable) / D(Disable) or Esc. to Abort
```

Press **D** to Disable (**E** to Enable); then press ENTER.

Press <D><ENTER>

```
Device now disabled
TROUBL SMOKE(PHOTO) DETECTOR ADDR 101 Z03 DEVICE DISABLED 08:29A Tue 04/15/08 D101
```

### C.4.4 Change Alarm and Pre-Alarm Levels

This option lets you change the Alarm and Pre-alarm levels of any addressable detector in the system. Follow these steps.

1. From the “Alter Status” menu select option **2** - Alarm/Pre-alarm.

Press <2><ENTER>

```
Det. Alarm/Prealarm level, type address D(
TROUBL SMOKE(PHOTO) DETECTOR ADDR 101 Z03 DEVICE DISABLED 08:29A Tue 04/15/08 D101
```

2. Enter the address of the detector you wish to change. For example, change alarm and pre-alarm levels for detector 102 on SLC 1 to Alarm Level 4 & Pre-alarm Level 2.

Press <1><D><1><0><2><ENTER><A><5><P><2><ENTER>

```
STATUS CHANGE Alarm/Prealarm level                               08:29A Tue 04/15/08
D102 sens. at level 5, Prealarm at level 3, Enter AxPx to change, Esc. to Abort
D102 now set at new Alarm level 5 and new Pre-alarm level 2
```

### C.4.5 Clear Verification Counter

Clear verification lets you clear the verification counter for all the addressable detectors in the system.

Press <3><ENTER>

```
STATUS CHANGE   Clear verify count           08:29A Tue 04/15/08
```

### C.4.6 Clear the Entire History Buffer

Clear History lets you clear the entire History buffer.

Press <4><ENTER>

```
*****History Clear*****
```

### C.4.7 Set the Pre-Alarm for Alert or Action

Set Action/Alert lets you set the Pre-alarm for Alert or Action. For example, change Pre-alarm from “Alert” to “Action” as follows:

Press <5><ENTER>

```
Set Pre-alarm Alert (NO)/Action(YES). Type N or Y then Enter
STATUS CHANGE   Change Alert/Action           08:29A Tue 04/15/08
```

Press <Y><ENTER>

```
Pre-alarm now set for ACTION
```

# Appendix D: Point and System Troubles Lists

There are a variety of point or system trouble types that may appear in a trouble message. The tables below give lists of the troubles and indications of their cause.

## D.1 Point (Device) Troubles

A message from the “Trouble Type” column in the following table will appear in the upper right corner of the panel display when a point (device) trouble occurs. Use this table to help determine what the trouble is.

POINT TROUBLES		
TROUBLE TYPE	TROUBLE DESCRIPTION	ACTION
AC FAILURE	The auxiliary power supply has lost AC power.	Determine whether there is an AC power loss or whether the power supply and wiring is correct.
ADRFMT	Detector and new sounder base address doesn't match. Or the ACPS address is incorrect.	Readdress the incorrect device.
ALIGN	A beam detector is in configuration mode.	No action is necessary, as the trouble will clear when the configuration is complete. However, the detector will not detect a fire while this trouble exists.
BLOCK	Something has come between the detector's beam and its reflector.	Investigate and clear the blockage.
CHGFLT	The power supply's battery charger is not working properly.	Correct the fault.
CO 6MN	The CO (carbon monoxide) detection element on an FSC-851 IntelliQuad detector has six months left to expiration. (This trouble generates in FlashScan mode only. CLIP mode will generate a LO VAL error.)	Replace the detector.
CO EXP	The CO (carbon monoxide) detection element on an FSC-851 IntelliQuad detector has reached the expiration date. (This trouble generates in FlashScan mode only. CLIP mode will generate a LO VAL error.)	Replace the detector.
CO TBL	The CO element on an FSC-851 IntelliQuad detector is not working properly. (This trouble generates in FlashScan mode only. CLIP mode will generate a LO VAL error.)	Replace the detector.
DIRTY 1	The detector is dirty and needs cleaning	Clean the detector.
DIRTY 2	The detector requires cleaning immediately. It is a false alarm risk.	Clean the detector immediately.
DISABL	The point has been disabled.	Service and re-enable the point.
GNDFLT	There is a ground fault on the main or auxiliary power supply.	Correct the fault.
HI BAT	The auxiliary power supply's battery charge is too high.	Check the batteries for problems. Replace batteries if necessary.
INVREP	The device has returned a response to the panel that the panel did not expect.	Check the device for functionality, addressing and wiring.
IR TBL	The infrared element is not working properly on an FSC-851 IntelliQuad detector. (This trouble generates in FlashScan mode only. CLIP mode will generate a LO VAL error.)	Replace the detector.
LO BAT	The auxiliary power supply's battery charge is low.	Check the batteries for problems. Replace batteries if necessary.
LO TEMP	The temperature read by a Heat+ or Acclimate™+ detector is too low.	Raise the heat in the area of the detector.
LO VAL	The detector chamber reading is too low; the detector is not operating properly. Or (CLIP Mode only) the thermistors, CO element, or infra-red element on an FSC-851 IntelliQuad detector is not working properly, or the FSC-851 IntelliQuad is experiencing a freeze warning.	The detector must be removed and replaced by an authorized service representative.
NO ANS	The device (module or detector) is not responding to the poll. Either the device is not working or it is not connected properly.	Determine whether the device is functional, and connected and addressed properly on the SLC.
NO SIG	The device (module or detector) is not responding to the poll. Either the device is not working or it is not connected properly.	Determine whether the device is functional, and connected and addressed properly on the SLC.
OPEN	The module device has an open circuit on its supervised wiring.	Check the connections from the module to the input or output device to which it is wired.
OPEN ON <u>x</u>	There is an open on speaker circuit <u>x</u> .	Locate the open and fix.
PSFAIL	The power supply is not working properly.	Check the battery for problems. Replace battery if necessary.
PRLOSS	The output module or new sounder base lost power.	Turn power back on.
SHORT	The module device has a short circuit on its supervised wiring.	Check the connections from the module to the input or output device to which it is wired.
SHORT ON <u>x</u>	There is a short on speaker circuit <u>x</u> .	Locate the short and fix.

Table D.1 Point (Device) Troubles (1 of 2)

POINT TROUBLES		
TROUBLE TYPE	TROUBLE DESCRIPTION	ACTION
TEST F	This detector has failed the FACP's periodic detector test for alarm capabilities.	The detector should be removed and replaced by an authorized service representative.
THERM	The thermistors are not functioning properly on an FSC-851 IntelliQuad detector. (This trouble generates in FlashScan mode only. CLIP mode will generate a LO VAL error.)	Replace the detector.
VER HI	This detector, which has been programmed to participate in alarm verification, has gone into and come out of verification its programmed limit without going into alarm. Either something is wrong with the detector or there is a condition nearby (such as someone smoking) that causes it to go into verification frequently.	Check the detector and the nearby conditions to determine the problem.
XP TBL	XPIQ general trouble.	Check the XPIQ point for problems.

Table D.1 Point (Device) Troubles (2 of 2)

## D.2 System Troubles

A message from the “Trouble Type” column in the following table will appear in the panel display when a system trouble occurs. Use this table to help determine the cause of the trouble.

SYSTEM TROUBLES		
TROUBLE MESSAGE TYPE	TROUBLE DESCRIPTION	ACTION
AC FAIL	The main power supply has lost AC power.	Investigate whether there is an AC power loss, or whether the PS is correctly installed and wired.
ADV WALK TEST	There is an Advanced Walk Test in progress.	No action is required.
ANNUN $\underline{x}$ NO ANSWER	The annunciator at address $\underline{x}$ is not responding.	Determine whether the device is functional, and connected and addressed properly.
ANNUN $\underline{x}$ TROUBLE	The annunciator at address $\underline{x}$ is in trouble.	Determine if the ACS module is functional, correctly installed, and configured properly.
AUXILIARY TROUBLE	An auxiliary device connected to the CPU2-640 at J6 is in trouble or the cable is missing.	Check the wiring and source.
BASIC WALK TEST	A Basic Walk Test is in progress.	No action is required.
BATTERY	The main power supply's battery charge is too high or too low.	Check batteries, replace if necessary.
BAT.BACKUP RAM	RAM battery backup is low.	Replace battery.
CHARGER FAIL	The main power supply's battery charger is not working properly.	Correct the fault.
CORRUPT LOGIC EQUAT	The database that houses the panel's logic equations is corrupt.	The database must be re-downloaded, or all programming must be cleared and re-entered.
DRILL ACTIVATED	Drill has been activated.	No action is required.
DETECTOR INITIALIZE	The detectors are initializing.	No action is required, as the trouble will clear when initialization is completed. However, the detector will not detect a fire while this trouble exists.
DVC ANALOG OUT $\underline{x}$ TBL	A trouble has occurred on DVC-AO analog output $\underline{x}$ (1-4). The analog output is configured for style 7, but no audio signal is returned.	Investigate and fix.
DVC AUDIO LIB. CORRUP	The audio library is corrupt.	The library must be re-downloaded, or all programming must be cleared and re-entered. If the trouble still does not clear, contact Technical Services.
DVC AUDIO LIB. INCOMP	The application or database version is incompatible.	The correct application or database version must be downloaded.
DVC BUZZER OFF-LINE	The piezo is disabled.	Re-enable the piezo at switch 5 on the DVC.
DVC DAA DOWNLOADING	A DAA download is in progress.	No action is required.
DVC DATABASE CORRUPT	The database that houses the DVC's programming is corrupt.	The database must be re-downloaded, or all programming must be cleared and re-entered. If the trouble still does not clear, contact Technical Services.
tDVC FFT Riser TBL		

Table D.2 System Troubles

SYSTEM TROUBLES		
TROUBLE MESSAGE TYPE	TROUBLE DESCRIPTION	ACTION
DVC DBASE INCOMPAT	The application or database version is incompatible.	The correct application or database version must be downloaded.
DVC DVC AUX TROUBLE	This trouble is generated when the auxiliary input is supervised (as determined in VeriFire toolsprogramming) and no signal is coming from the input.	Check the wiring and source.
DVC EXT RAM ERROR	The external RAM test failed.	Service is required.
DVC FFT TROUBLE	There is a short or open on the FFT riser.	Check that the 4-wire switch is correctly set and that there is an end-of-line resistor in place for 2-wire operation.
DVC FLASH IMAGE ERR	The DVC software is corrupt.	Re-download the panel code software from VeriFire tools. If the trouble still does not clear, call Technical Services.
DVC LOADING NO SERV	A program or database download is in progress. The panel is NOT providing fire protection during the download.	Proper authorities should be notified while a download is in progress so that other means of fire protection can be supplied.
DVC LOCAL MIC. TBL	The local microphone is in trouble. There is no communication, or paging has been enabled for over 28 seconds and no signal has been received.	Investigate whether the mic is plugged into the DVC or whether there is a problem with the local mic.
DVC LOCAL PHONE TBL	The local FFT handset is in trouble. There is no communication, or paging has been enabled for over 28 seconds and no signal has been received.	Investigate whether the handset is plugged into the DVC or whether there is a problem with the local handset.
DVC NVRAM BATT TBL	Battery backup and/or clock backup is low.	Replace the battery. Refer to the <i>DVC Series Manual</i> for replacement instructions.
DVC PROGRAM CORRUPT	The database that houses the DVC's programming is corrupt.	The database must be re-downloaded, or all programming must be cleared and re-entered. If the trouble still does not clear, contact Technical Services.
DVC REM. MIC. TBL	The remote microphone is in trouble. It is installed and supervised, but no signal is coming from it.	Check wiring and connections.
DVC SELF TEST FAIL	The diagnostic test failed on the DVC.	Call Technical Services.
DVC SOFT. MISMATCH	One or more DAAs has a software revision that does not match other DAA software revisions.	Update the DAA software to match.
EPROM ERROR	The application and/or boot code is corrupt.	Service is required.
EXCEEDED CONN. LIMIT	More than two panels have been connected to a high-speed network communications module.	Remove extra panel(s).
EXTERNAL RAM ERROR	The external RAM test failed.	Service is required.
GROUND FAULT	A ground fault has occurred within the panel.	Locate the ground fault and repair.
GROUND FAULT LOOP $x$	There is a ground fault on loop $x$ .	Locate the ground fault and repair.
HS-NCM SNIFFER ACTIV	The panel is in a diagnostic mode.	No action is required.
INTERNAL RAM ERROR	The internal RAM test failed.	Service is required.
LCD80 SUPERVISORY	Communication has been lost with the LCD-80.	Check connections to the LCD-80 Annunciator.
LOADING.NO SERVICE	A program or database download is in progress. The panel is NOT providing fire protection during the download.	Proper authorities should be notified while a download is in progress so that other means of fire protection can be supplied.
MASTER BOX TROUBLE	A TM-4 connected to a municipal box is in trouble.	Reset the master box.
MASTER BOX NO ANSWER	A TM-4 connected to a municipal box is not responding.	Determine whether the device is functional and connected properly.
NCM COMM FAILURE	Communication is lost between the CPU2-640 and the network communications module or DVC.	Check to see if the NUP cable is properly installed and the network communications module or DVC is functional.
NETWORK FAIL PORT $x$	Communication lost between NCM Port $x$ and corresponding node.	Check wiring and verify the node is online.
NETWORK INCOMPATIBLE	The brand of this panel is incompatible with this network.	Verify all nodes are branded for the same OEM.
NFPA 24HR REMINDER	This message occurs every day at 11 AM if any troubles exist.	Resolve any troubles on the system.
NO DEV. INST ON L1	No devices are installed on the system.	Install SLC and run autoprogram.
PANEL DOOR OPEN	The panel door is open.	Close door.

Table D.2 System Troubles

SYSTEM TROUBLES		
TROUBLE MESSAGE TYPE	TROUBLE DESCRIPTION	ACTION
POWER SUPPLY COMM FAIL	There has been a communication failure with the power supply.	Service is required.
PROGRAM CORRUPTED	The database that houses the panel's programming is corrupt.	The database must be re-downloaded, or all programming must be cleared and re-entered. If the trouble still does not clear, contact Technical Services.
PROGRAM MODE ACTIVATED	A user is currently accessing the panel's programming menus.	No action is required / Exit the Programming mode.
RELEASE DEV. DISABLE	Releasing devices have been disaled.	Enable the devices.
SELF TEST FAILED	Diagnostic test failed.	Call Technical Services.
STYLE 6 POS. LOOP $\underline{x}$	There is an open circuit on the positive side of loop $x$ . Style 6 and Style 7 are supervised methods of communicating with addressable devices. If the control panel detects a trouble (open), it will drive both ends of the loop, maintaining communication in an unsupervised method. The latching trouble will display on the panel as a Style 6 trouble until you correct the condition and press RESET. Style 7 configuration of the SLC requires the use of ISO-X isolator modules.	
STYLE 6 NEG. LOOP $\underline{x}$	There is an open circuit on the negative side of loop $\underline{x}$ . Style 6 and Style 7 are supervised methods of communicating with addressable devices. If the control panel detects a trouble (open), it will drive both ends of the loop, maintaining communication in an unsupervised method. The latching trouble will display on the panel as a Style 6 trouble until you correct the condition and press RESET. Style 7 configuration of the SLC requires the use of ISO-X isolator modules.	
STYLE 6 SHORT LOOP $\underline{x}$	Style 6 and Style 7 are supervised methods of communicating with addressable devices. If the control panel detects a trouble (open or short), it will drive both ends of the loop, maintaining communication in an unsupervised method. The latching trouble will display on the panel as a Style 6 trouble until you correct the condition and press RESET. Style 7 configuration of the SLC requires the use of ISO-X isolator modules.	
TERM. SUPERVISORY	There is a communication error with the CRT-2.	Check connections to the CRT-2 terminal.
UDACT NO ANSWER	The UDACT is not responding.	Determine whether the UDACT is functional, and connected and addressed properly.
UDACT TROUBLE	The UDACT is in trouble.	Determine if the UDACT is functional and wired correctly.

Table D.2 System Troubles

## NOTES



## NOTES

# Index

## A

Abort **51**  
Abort Active LED **14**  
Acknowledge/Scroll Display control key **14**  
Active Supervisory Signal **25–26**  
    panel indication **25**  
    response to **26**  
    Type Codes **26**  
Alarm Verification Timer **33, 61**  
Alarm. See Fire Alarm **20**  
Analog Display **61**  
Annunciator Selections, read status **42**  
Auto Silence Timer **33**  
Automatic Test Operation **61**

## B

Battery Levels, read status **44**

## C

Caution  
    Disabling a zone disables all input and output... **28**  
Coding  
    to view F8 selections **56**  
Coding, NAC **56**  
Control Keys **14**  
Control/Relay Module Trouble  
    panel indication **32**  
    response to **32**  
    Type Codes **31**  
Control/Relay Module, read status **38**  
Controls Active LED **13**  
Cooperative Multi-Detector, read status **38**  
Cross Zone **51**  
Cross Zone Programming illustration **53**  
CRT-2 and Read Status **65**  
    Accessing **65**  
CRT-2 and Read Status. See Appendix C

## D

Date Functions **54**  
Day/Night Sensitivity Operation **61**  
Delay Timer **51**  
Detector  
    fire alarm type codes **22**  
    Functions **61**  
    Read Status **38**  
    supervisory alarm type codes **27**  
Disabled Points **28**  
Discharge LED **14**  
Drill control key **15**

## F

Fire Alarm **20–21**  
    LED **14**  
    panel indication **20**  
    response to a **20, 57**  
Fire Control Type Code, active point **29**

## H

Hidden History, read status and print **48**  
History, event and alarm, read status **45**  
Holiday Functions **54**  
    to view selections **55**

## I

Increment Number key **17**  
ISO-X module **34, 74**

## L

Lamp Test control key **17**  
Latching Supervisory Type Code **26**  
Latching/non-latching type codes. See particular type code for definition.  
LED Control Operation **61**  
LEDs, table of **13**  
Local Control setting and control keys **15**  
LocM (Local Monitor) **63, 64**  
LocT (Local Terminal Mode) **63**

## M

Maintenance Alert **61**  
Manual Release **51**  
Monitor Module  
    fire alarm type codes **21**  
    non-alarm type codes **29**  
    Read Status **38**  
    security type codes **25**  
    supervisory alarm type codes **26**  
    trouble monitor type codes **30**

## N

NAC Trouble  
    panel indication **32**  
    response to **32**  
    Type Codes **31**  
NAC, read status **39**  
Non-Alarm Points **29**  
Non-Fire Point, active, panel indication **30**  
Non-latching Supervisory Type Code **26**  
Normal Mode of Operation **19**

**O**

Output Circuit Trouble **31–32**

**P**

Partial Signal Silence **15**

Point (Device) Troubles table **71**

Point Disabled LED **14**

Power LED **13**

Pre-alarm LED **14**

Pre-Alarm Warning **27**

    action level **27**

    alert level **27**

    panel indication **27**

    response to **27**

Pre-Discharge LED **14**

Presignal and Positive Alarm Sequence (PAS)

    response to Presignal Delay Timer alarm  
    (no PAS) **58**

    response to Presignal Delay Timer alarm  
    (PAS selected) **59**

    to view selections **58**

**R**

Read Status **35–48**

    to enter **35**

    to print **46**

        alarm history **47**

        event history **47**

        points **46**

        print hidden event and alarm history  
        **48**

        print points **47**

    to view **36**

        annunciator selections **42**

        battery levels **44**

        detector information **37**

        devices, zones, system settings **36**

        event and alarm history **45**

        point or zone information **37**

        Releasing Zone (R0-R9) **41**

        releasing zone selections

        software zones **40**

        Special Zone (F0-F9) **40**

        System Functions **41**

        total of installed devices **37**

    using a CRT. See Appendix C

Recall Last Entry key **17**

Releasing Zone (R0-R9), read status **41**

Releasing Zones (R0-R9) **51–53**

Remote Terminal Access **63–70**

RemT, Remote Terminal Mode **63, 64**

**S**

Security Alarm **24**

    panel indication **24**

    response to a **24**

Security LED **14**

Sensitivity Adjust **61**

Shortcuts to Operating Functions **11**

Signal Silence control key **15**

Signals Silenced LED **14**

Silence Inhibit Timer **33**

Soak Timer **51**

Software Zone (Z01-Z99), read status **40**

Special Zone Operation **51–59**

Special Zone, read status **40**

Supervisory LED **14**

Supplemental Documentation **10**

System Functions, read status **41**

System Normal Message **19**

System Reset control key **15**

System Timers **33**

    Alarm Verification Timer **33**

    Auto Silence Timer **33**

    Silence Inhibit Timer **33**

    to view selections **33**

System Trouble **22–24**

    panel indication **22**

    response to **23**

System Trouble LED **14**

System Troubles **72**

**T**

Time Functions **54**

    to view selections **54**

Timers. See System Timers **33**

Transponder Points **31**

Trouble Monitor **30**

    response to **30**

    trouble monitor type codes **30**

Troubles

    Point **71**

    System **72**

Type Code Supervision **61**

Type Codes

    Fire Alarm **21**

    Non-alarm **29**

    Security **25**

    Supervisory **26**

    Trouble **30**

**W**

Warning

    When used for CO2 releasing applica-  
    tions... **19, 51**

Waterflow Circuit operation **34**

**X**

XP6-C **31**

XPC transponder points **31**

## Manufacturer Warranties and Limitation of Liability

**Manufacturer Warranties.** Subject to the limitations set forth herein, Manufacturer warrants that the Products manufactured by it in its Northford, Connecticut facility and sold by it to its authorized Distributors shall be free, under normal use and service, from defects in material and workmanship for a period of thirty six months (36) months from the date of manufacture (effective Jan. 1, 2009). The Products manufactured and sold by Manufacturer are date stamped at the time of production. Manufacturer does not warrant Products that are not manufactured by it in its Northford, Connecticut facility but assigns to its Distributor, to the extent possible, any warranty offered by the manufacturer of such product. This warranty shall be void if a Product is altered, serviced or repaired by anyone other than Manufacturer or its authorized Distributors. This warranty shall also be void if there is a failure to maintain the Products and the systems in which they operate in proper working conditions.

MANUFACTURER MAKES NO FURTHER WARRANTIES, AND DISCLAIMS ANY AND ALL OTHER WARRANTIES, EITHER EXPRESSED OR IMPLIED, WITH RESPECT TO THE PRODUCTS, TRADEMARKS, PROGRAMS AND SERVICES RENDERED BY MANUFACTURER INCLUDING WITHOUT LIMITATION, INFRINGEMENT, TITLE, MERCHANTABILITY, OR FITNESS FOR ANY PARTICULAR PURPOSE. MANUFACTURER SHALL NOT BE LIABLE FOR ANY PERSONAL INJURY OR DEATH WHICH MAY ARISE IN THE COURSE OF, OR AS A RESULT OF, PERSONAL, COMMERCIAL OR INDUSTRIAL USES OF ITS PRODUCTS.

This document constitutes the only warranty made by Manufacturer with respect to its products and replaces all previous warranties and is the only warranty made by Manufacturer. No increase or alteration, written or verbal, of the obligation of this warranty is authorized. Manufacturer does not represent that its products will prevent any loss by fire or otherwise.

**Warranty Claims.** Manufacturer shall replace or repair, at Manufacturer's discretion, each part returned by its authorized Distributor and acknowledged by Manufacturer to be defective, provided that such part shall have been returned to Manufacturer with all charges prepaid and the authorized Distributor has completed Manufacturer's Return Material Authorization form. The replacement part shall come from Manufacturer's stock and may be new or refurbished. THE FOREGOING IS DISTRIBUTOR'S SOLE AND EXCLUSIVE REMEDY IN THE EVENT OF A WARRANTY CLAIM.

Warn-HL-08-2009.fm



---

World Headquarters  
12 Clintonville Road  
Northford, CT 06472-1610 USA  
203-484-7161  
fax 203-484-7118

[www.notifier.com](http://www.notifier.com)

**ISO 9001**  
**CERTIFIED**  
ENGINEERING & MANUFACTURING  
QUALITY SYSTEMS

# SECTION

# 4.3

Notifier Manual 52742

NFS2-640 Control Panel  
Programming



**Fire Alarm Control Panel**  
**NFS2-640/E**  
**Programming Manual**

Document 52742

5/7/10

Rev:

**D**

P/N 52742:D

ECN 10-249



# Fire Alarm System Limitations

*While a fire alarm system may lower insurance rates, it is not a substitute for fire insurance!*

**An automatic fire alarm system**—typically made up of smoke detectors, heat detectors, manual pull stations, audible warning devices, and a fire alarm control panel with remote notification capability—can provide early warning of a developing fire. Such a system, however, does not assure protection against property damage or loss of life resulting from a fire.

The Manufacturer recommends that smoke and/or heat detectors be located throughout a protected premise following the recommendations of the current edition of the National Fire Protection Association Standard 72 (NFPA 72), manufacturer's recommendations, State and local codes, and the recommendations contained in the Guides for Proper Use of System Smoke Detectors, which are made available at no charge to all installing dealers. These documents can be found at <http://www.systemsensor.com/html/applicat.html>. A study by the Federal Emergency Management Agency (an agency of the United States government) indicated that smoke detectors may not go off in as many as 35% of all fires. While fire alarm systems are designed to provide early warning against fire, they do not guarantee warning or protection against fire. A fire alarm system may not provide timely or adequate warning, or simply may not function, for a variety of reasons:

**Smoke detectors** may not sense fire where smoke cannot reach the detectors such as in chimneys, in or behind walls, on roofs, or on the other side of closed doors. Smoke detectors also may not sense a fire on another level or floor of a building. A second-floor detector, for example, may not sense a first-floor or basement fire.

**Particles of combustion or "smoke"** from a developing fire may not reach the sensing chambers of smoke detectors because:

- Barriers such as closed or partially closed doors, walls, or chimneys may inhibit particle or smoke flow.
- Smoke particles may become "cold," stratify, and not reach the ceiling or upper walls where detectors are located.
- Smoke particles may be blown away from detectors by air outlets.
- Smoke particles may be drawn into air returns before reaching the detector.

The amount of "smoke" present may be insufficient to alarm smoke detectors. Smoke detectors are designed to alarm at various levels of smoke density. If such density levels are not created by a developing fire at the location of detectors, the detectors will not go into alarm.

Smoke detectors, even when working properly, have sensing limitations. Detectors that have photoelectronic sensing chambers tend to detect smoldering fires better than flaming fires, which have little visible smoke. Detectors that have ionizing-type sensing chambers tend to detect fast-flaming fires better than smoldering fires. Because fires develop in different ways and are often unpredictable in their growth, neither type of detector is necessarily best and a given type of detector may not provide adequate warning of a fire.

Smoke detectors cannot be expected to provide adequate warning of fires caused by arson, children playing with matches (especially in bedrooms), smoking in bed, and violent explosions (caused by escaping gas, improper storage of flammable materials, etc.).

**Heat detectors** do not sense particles of combustion and alarm only when heat on their sensors increases at a predetermined rate or reaches a predetermined level. Rate-of-rise heat detectors may be subject to reduced sensitivity over time. For this reason, the rate-of-rise feature of each detector should be tested at least once per year by a qualified fire protection specialist. Heat detectors are designed to protect property, not life.

**IMPORTANT! Smoke detectors** must be installed in the same room as the control panel and in rooms used by the system for the connection of alarm transmission wiring, communications, signaling, and/or power. If detectors are not so located, a developing fire may damage the alarm system, crippling its ability to report a fire.

**Audible warning devices** such as bells may not alert people if these devices are located on the other side of closed or partly open doors or are located on another floor of a building. Any warning device may fail to alert people with a disability or those who have recently consumed drugs, alcohol or medication. Please note that:

- Strobes can, under certain circumstances, cause seizures in people with conditions such as epilepsy.
- Studies have shown that certain people, even when they hear a fire alarm signal, do not respond or comprehend the meaning of the signal. It is the property owner's responsibility to conduct fire drills and other training exercise to make people aware of fire alarm signals and instruct them on the proper reaction to alarm signals.
- In rare instances, the sounding of a warning device can cause temporary or permanent hearing loss.

**A fire alarm system** will not operate without any electrical power. If AC power fails, the system will operate from standby batteries only for a specified time and only if the batteries have been properly maintained and replaced regularly.

**Equipment used in the system** may not be technically compatible with the control panel. It is essential to use only equipment listed for service with your control panel.

**Telephone lines** needed to transmit alarm signals from a premise to a central monitoring station may be out of service or temporarily disabled. For added protection against telephone line failure, backup radio transmission systems are recommended.

**The most common cause** of fire alarm malfunction is inadequate maintenance. To keep the entire fire alarm system in excellent working order, ongoing maintenance is required per the manufacturer's recommendations, and UL and NFPA standards. At a minimum, the requirements of NFPA 72 shall be followed. Environments with large amounts of dust, dirt or high air velocity require more frequent maintenance. A maintenance agreement should be arranged through the local manufacturer's representative. Maintenance should be scheduled monthly or as required by National and/or local fire codes and should be performed by authorized professional fire alarm installers only. Adequate written records of all inspections should be kept.

Limit-C1-2-2007

# Installation Precautions

*Adherence to the following will aid in problem-free installation with long-term reliability:*

**WARNING - Several different sources of power can be connected to the fire alarm control panel.** Disconnect all sources of power before servicing. Control unit and associated equipment may be damaged by removing and/or inserting cards, modules, or interconnecting cables while the unit is energized. Do not attempt to install, service, or operate this unit until manuals are read and understood.

**CAUTION - System Re-acceptance Test after Software Changes:** To ensure proper system operation, this product must be tested in accordance with NFPA 72 after any programming operation or change in site-specific software. Re-acceptance testing is required after any change, addition or deletion of system components, or after any modification, repair or adjustment to system hardware or wiring. All components, circuits, system operations, or software functions known to be affected by a change must be 100% tested. In addition, to ensure that other operations are not inadvertently affected, at least 10% of initiating devices that are not directly affected by the change, up to a maximum of 50 devices, must also be tested and proper system operation verified.

**This system** meets NFPA requirements for operation at 0-49° C/32-120° F and at a relative humidity 93% ± 2% RH (non-condensing) at 32°C ± 2°C (90°F ± 3°F). However, the useful life of the system's standby batteries and the electronic components may be adversely affected by extreme temperature ranges and humidity. Therefore, it is recommended that this system and its peripherals be installed in an environment with a normal room temperature of 15-27° C/60-80° F.

**Verify that wire sizes are adequate** for all initiating and indicating device loops. Most devices cannot tolerate more than a 10% I.R. drop from the specified device voltage.

**Like all solid state electronic devices,** this system may operate erratically or can be damaged when subjected to lightning induced transients. Although no system is completely immune from lightning transients and interference, proper grounding will reduce susceptibility. Overhead or outside aerial wiring is not recommended, due to an increased susceptibility to nearby lightning strikes. Consult with the Technical Services Department if any problems are anticipated or encountered.

**Disconnect AC power and batteries** prior to removing or inserting circuit boards. Failure to do so can damage circuits.

**Remove all electronic assemblies** prior to any drilling, filing, reaming, or punching of the enclosure. When possible, make all cable entries from the sides or rear. Before making modifications, verify that they will not interfere with battery, transformer, or printed circuit board location.

**Do not tighten screw terminals** more than 9 in-lbs. Overtightening may damage threads, resulting in reduced terminal contact pressure and difficulty with screw terminal removal.

**This system contains static-sensitive components.** Always ground yourself with a proper wrist strap before handling any circuits so that static charges are removed from the body. Use static suppressive packaging to protect electronic assemblies removed from the unit.

**Follow the instructions** in the installation, operating, and programming manuals. These instructions must be followed to avoid damage to the control panel and associated equipment. FACP operation and reliability depend upon proper installation.

Precau-D1-9-2005

## Installation Precautions

*Adherence to the following will aid in problem-free installation with long-term reliability:*

**WARNING - Several different sources of power can be connected to the fire alarm control panel.** Disconnect all sources of power before servicing. Control unit and associated equipment may be damaged by removing and/or inserting cards, modules, or interconnecting cables while the unit is energized. Do not attempt to install, service, or operate this unit until manuals are read and understood.

**CAUTION - System Re-acceptance Test after Software Changes:** To ensure proper system operation, this product must be tested in accordance with NFPA 72 after any programming operation or change in site-specific software. Re-acceptance testing is required after any change, addition or deletion of system components, or after any modification, repair or adjustment to system hardware or wiring. All components, circuits, system operations, or software functions known to be affected by a change must be 100% tested. In addition, to

HARSH™, NIS™, Notifier Integrated Systems™, and NOTI-FIRE-NET™ are all trademarks; and Acclimate® Plus, FlashScan®, NION®, NOTIFIER®, ONYX®, ONYXWorks®, UniNet®, VeriFire®, and VIEW® are all registered trademarks of Honeywell International Inc. Echelon® is a registered trademark and LonWorks™ is a trademark of Echelon Corporation. ARCNET® is a registered trademark of Datapoint Corporation. Microsoft® and Windows® are registered trademarks of the Microsoft Corporation.

©2010 by Honeywell International Inc. All rights reserved. Unauthorized use of this document is strictly prohibited.

## Software Downloads

In order to supply the latest features and functionality in fire alarm and life safety technology to our customers, we make frequent upgrades to the embedded software in our products. To ensure that you are installing and programming the latest features, we strongly recommend that you download the most current version of software for each product prior to commissioning any system. Contact Technical Support with any questions about software and the appropriate version for a specific application.

## Documentation Feedback

Your feedback helps us keep our documentation up-to-date and accurate. If you have any comments or suggestions about our online Help or printed manuals, you can email us.

Please include the following information:

- Product name and version number (if applicable)
- Printed manual or online Help
- Topic Title (for online Help)
- Page number (for printed manual)
- Brief description of content you think should be improved or corrected
- Your suggestion for how to correct/improve documentation

Send email messages to:

**FireSystems.TechPubs@honeywell.com**

Please note this email address is for documentation feedback only. If you have any technical issues, please contact Technical Services.

# Table of Contents

<b>Section 1: General Information.....</b>	<b>9</b>
1.1: UL 864 Compliance.....	9
1.1.1: Products Subject to AHJ Approval.....	9
1.1.2: Programming Features Subject to AHJ Approval .....	9
1.2: About This Manual .....	9
1.2.1: Cautions, Warning, and Notes.....	9
1.2.2: Typographic Conventions.....	10
1.2.3: Supplemental Information .....	10
1.2.4: Shortcuts to Operating Functions .....	12
1.3: Introduction to the Control Panel .....	12
1.4: Features.....	12
1.5: How to Enter a Password.....	13
<b>Section 2: Programming .....</b>	<b>14</b>
2.1: Overview.....	14
2.2: How to Enter Programming.....	14
2.3: Basic Program.....	15
2.3.1: Clear Memory (0=CLR).....	16
2.3.2: Autoprogram the Control Panel (1=AUTO).....	16
2.3.3: Modify or Delete a Point (2=POINT).....	20
2.3.4: Change a Password (3=PASSWD).....	26
2.3.5: Create a System Message (4=MESSAGE) .....	27
2.3.6: Create a Custom Zone Label (5=ZONE).....	28
2.3.7: Program Special Zones (6=SPL FUNCT).....	28
2.3.8: Change Global System Functions (7=SYSTEM).....	32
2.3.9: How to Check the Program for Errors (8=CHECK PRG).....	41
2.4: The Network Program .....	42
2.5: The Utility Program.....	42
2.6: FlashScan Poll .....	44
2.7: Setting the Baud Rate of Serial Ports .....	44
2.7.1: Printer Serial Port .....	44
2.7.2: CRT Serial Port .....	45
<b>Section 3: Status Change.....</b>	<b>47</b>
3.1: Overview.....	47
3.2: How to Enter Status Change.....	47
3.3: Disable or Enable a Point .....	48
3.4: Changing Detector Sensitivity .....	49
3.5: Clearing Alarm Verification Counters .....	50
3.6: Clearing the History Buffer .....	50
3.7: Setting the System Time and Date.....	50
3.8: Walk Test .....	51
3.8.1: Basic Walk Test.....	52
3.8.2: Advanced Walk Test .....	53
3.8.3: Walk Test Activation Indications .....	53
3.8.4: Viewing Walk Test Results .....	54
<b>Appendix 4: Releasing Applications.....</b>	<b>55</b>
4.1: Overview.....	55
4.1.1: Description of Releasing Zones.....	55
4.1.2: NFPA Releasing Applications.....	56
4.2: How to Program a Releasing Zone .....	56
4.2.1: Programming a Delay Timer .....	56
4.2.2: Abort Switches .....	57
4.2.3: Using Cross Zones.....	65

4.2.4: Programming a Soak Timer .....	67
4.2.5: Using Type Codes for Releasing Zones .....	68
4.3: Initiating Devices .....	87
4.4: Warning Sounders .....	87
4.5: Auxiliary Control Functions .....	87
4.6: ACS Annunciation .....	87
<b>Appendix 5: Special Zone Outputs .....</b>	<b>88</b>
5.1: Presignal and Positive Alarm Sequence (PAS) .....	88
5.1.1: What is Presignal and PAS? .....	88
5.1.2: Selecting Presignal and PAS Outputs .....	89
5.2: Time Control Zones .....	89
5.3: Coding Functions for NACS .....	89
<b>Appendix 6: Intelligent Sensing Applications .....</b>	<b>91</b>
6.1: Overview .....	91
6.2: Features .....	91
6.2.1: Drift Compensation and Smoothing .....	91
6.2.2: Maintenance Warnings – Three Levels .....	92
6.2.3: Self-Optimizing Pre-Alarm .....	93
6.2.4: Detector Sensitivity .....	93
6.2.5: Cooperative Multi-Detector Sensing .....	94
6.3: Pre-Alarm .....	95
6.3.1: Definition .....	95
6.3.2: Alert Level .....	95
6.3.3: Action Level .....	96
6.3.4: How to Select a Pre-Alarm Level .....	96
6.4: Detector Sensitivity Settings .....	97
6.4.1: How to Select Pre-Alarm and Alarm Sensitivity .....	97
6.4.2: How to Test Detectors Set Below 0.50% Obscuration per Foot .....	98
6.5: Detector Maintenance Features .....	99
6.5.1: Overview .....	99
6.5.2: How to Access Detector Maintenance Information .....	99
6.5.3: View Detector Maintenance for a Detector .....	99
6.5.4: Print a Detector Maintenance Report .....	100
6.5.5: Interpreting a Detector Status Display or Maintenance Report .....	100
<b>Appendix 7: CBE (Control-By-Event) .....</b>	<b>102</b>
7.1: Description .....	102
7.2: Input and Outputs .....	102
7.3: Equations .....	102
7.4: Equation Entry .....	103
7.4.1: Logic Functions .....	103
7.4.2: Equation Syntax Example .....	104
7.4.3: Evaluating an Equation .....	104
7.4.4: Argument Entries .....	104
7.4.5: Time Delay Functions .....	105
7.5: CBE Example .....	105
<b>Appendix 8: Detector Initialization .....</b>	<b>106</b>
8.1: Overview .....	106
8.2: System Testing and Detector Initialization .....	106
8.3: How to Replace a Detector .....	106
8.4: How to Manually Initialize a Detector .....	107
<b>Appendix 9: Type Codes .....</b>	<b>108</b>
9.1: What are Type Codes? .....	108
9.2: How to Select a Type Code .....	108

---

9.3: In this Appendix .....	108
9.4: Type Codes for Input Devices .....	108
9.4.1: Overview .....	108
9.4.2: Type Codes for Intelligent Detectors.....	108
9.4.3: Type Codes for Monitor Modules .....	110
9.5: Type Codes for Output Devices.....	111
9.5.1: Overview .....	111
9.5.2: Type Codes for Control Modules .....	112
9.5.3: NAC Type Codes.....	112
<b>Appendix 10: Region Settings .....</b>	<b>115</b>





# Section 1: General Information

## 1.1 UL 864 Compliance

### 1.1.1 Products Subject to AHJ Approval

This product has been certified to comply with the requirements in the Standard for Control Units and Accessories for Fire Alarm Systems, UL 864 9th Edition.

A complete listing identifying which products have or have not received UL 864 9th Edition certification is located in the installation manual of this fire alarm system. Those products which have not received UL 864 9th Edition certification may only be used in retrofit applications. Operation of the NFS2-640/E with products not tested for UL 864 9th Edition has not been evaluated and may not comply with NFPA 72 and /or UL 864. These applications will require the approval of the local Authority Having Jurisdiction (AHJ).

### 1.1.2 Programming Features Subject to AHJ Approval

This product incorporates field-programmable software. The features and/or options listed below must be approved by the local AHJ.

This product incorporates field-programmable software. In order for the product to comply with the requirements in the Standard for Control Units and Accessories for Fire Alarm Systems, UL 864, certain programming features or options must be limited to specific values or not used at all as indicated below.			
Program Feature or Option	Permitted in UL 864? (Y/N)	Possible Settings	Settings Permitted in UL 864
IP downloads over a local area network (LAN) or the internet (WAN - Wide Area Network)	No	Yes No Timed	No
Releasing: Abort Switch	Yes	NYC AHJ ULI IRI	ULI IRI
Detector Programming: Supervisory Type Codes	Yes	SUP L(DUCTI) SUP T(DUCTI) SUP T(DUCTP) SUP L(DUCTP) SUP L(ION) SUP T(ION) SUP L(PHOTO) SUP T(PHOTO) SUP L(LASER) SUP T(LASER)	SUP L(DUCTI) SUP T(DUCTI) SUP L(DUCTP) SUP T(DUCTP)
ALA.SCROLL (Scroll Display)	No	Y N	N
TBL.REMIND	Yes	*, 1, 2, 3, 4, 5	2
REGION	No	0 (No special setting) 1 (China)	0 (No special setting)

Table 1.1 Programming Settings

## 1.2 About This Manual

### 1.2.1 Cautions, Warning, and Notes

The following graphics appear in the manual to indicate a caution or a warning.



**CAUTION:**

Information about procedures that could cause programming errors, runtime errors, or equipment damage.

**WARNING:**


Information about procedures that could cause irreversible damage to the control panel, irreversible loss of programming data or personal injury.



**NOTE:** Information that highlights an important part of the preceding or subsequent text or illustration.

## 1.2.2 Typographic Conventions

This manual uses the following conventions as listed below:

When you see	Specifies	Example
text in small caps	the text as it appears in the LCD display or on the control panel	MARCH TIME is a selection that appears in the LCD display; or Press the ENTER key
text in quotes	a reference to a section or an LCD menu screen	“Status Change” specifies the Status Change section or menu screen
bold text	In body text, a number or character that you enter	Press <b>1</b> ; means to press the number “1” on the keypad
italic text	a specific document	<i>NFS2-640 Installation Manual</i>
a graphic of the key	In a graphic, a key as it appears on the control panel	Press  means to press the Escape key

**Table 1.2 Typographic Conventions in this Manual**



**NOTE:** The term NFS2-640 is used in this manual to refer to the NFS2-640 and NFS2-640E unless otherwise noted.

## 1.2.3 Supplemental Information

The table below provides a list of documents referenced in this manual, as well as documents for selected other compatible devices. The document series chart (DOC-NOT) provides the current document revision. A copy of this document is included in every shipment.

Compatible Conventional Devices (Non-addressable)	Document Number
Device Compatibility Document	15378
<b>Fire Alarm Control Panel (FACP) and Main Power Supply Installation</b>	<b>Document Number</b>
NFS2-640/E Installation, Operations, and Programming Manuals	52741, 52742, 52743
SLC Wiring Manual	51253
Note: For individual SLC Devices, refer to the <i>SLC Wiring Manual</i>	
<b>Off-line Programming Utility</b>	<b>Document Number</b>

**Table 1.3 Related Documentation (1 of 2)**

VeriFire® Tools CD help file	VERIFIRE-TCD
Veri•Fire Medium Systems Help File	VERIFIRE-CD
<b>Cabinets &amp; Chassis</b>	<b>Document Number</b>
CAB-3/CAB-4 Series Cabinet Installation Document	15330
Battery/Peripherals Enclosure Installation Document	50295
<b>Power Supplies, Auxiliary Power Supplies &amp; Battery Chargers</b>	<b>Document Number</b>
ACPS-610 Addressable Power Supply Manual	53018
ACPS-2406 Installation Manual	51304
APS-6R Instruction Manual	50702
APS2-6R Instruction Manual	53232
CHG-120 Battery Charger Manual	50641
FCPS-24 Field Charger/Power Supply Manual	50059
FCPS-24S Field Charger/Power Supply Manual (Sync)	51977
<b>Networking</b>	<b>Document Number</b>
Noti•Fire•Net Manual, Network Version 4.0 & Higher	51584
NCM-W/F Installation Document	51533
NCS Network Control Station Manual, Network Version 4.0 & Higher	51658
NCA-2 Network Control Annunciator Manual	52482
ONYXWorks™ Workstation Manuals	52305, 52306, 52307
<b>System Components</b>	<b>Document Number</b>
DVC/DAA Digital Audio Manual	52411
DAA Digital Audio Amplifier Product Installation Manual	52410
Annunciator Control System Manual	15842
Annunciator Fixed Module Manual	15048
AFM-16A Annunciator Fixed Module Manual	15207
ACM-8R Annunciator Control Module Manual	15342
LCD-80 Manual	15037
LCD2-80 Manual	53242
FDU-80 Remote Annunciator Manual	51264
LDM Series Lamp Driver Annunciator Manual	15885
SCS Smoke Control Manual (Smoke and HVAC Control Station)	15712
FireVoice NFV-25/50ZS Manual	52290
RPT-485W/RPT-485WF EIA-485 Annunciator Loop Repeater Manual	15640
DPI-232 Direct Panel Interface Manual	51499
TM-4 Installation Document (Reverse Polarity Transmitter)	51490
UDACT Manual (Universal Digital Alarm Communicator/Transmitter)	50050
ACT-2 Installation Document	51118
RM-1 Series Remote Microphone Installation Document	51138
RA400Z Remote LED Annunciator Installation Document	156-508
XPIQ Audio Transponder Manual	51013

Table 1.3 Related Documentation (2 of 2)

## 1.2.4 Shortcuts to Operating Functions



To the left of each program function, you'll find a keypad shortcut, which contains a series of keypad entries required to access the program function. All shortcuts start with the control panel in normal operation.



For example, the keypad shortcut to the left shows how to enter the Read Status function with the control panel in normal operation.

## 1.3 Introduction to the Control Panel

The NF2S-640 is an intelligent, field-programmable Fire Alarm Control Panel. Field-programming the control panel lets you customize the fire alarm system by selecting and setting program options for intelligent/addressable detectors and modules, and Notification Appliance Circuits (NACs).

This manual provides information for programming using the NFS2-640 keypad connected to the control panel. VeriFire™ Tools must be used for programming if no keypad is used, or if a network control annunciator is used as the keypad in either a network or standalone application. Refer to VeriFire™ Tools for information on programming without the NF2S-640 keypad, and the *NF2S-640 Installation Manual* and *NCA-2 Manual* for installation information.

For details on control panel operation, refer to the *NFS2-640 Operations Manual*.

The NF2S-640 provides two methods for field-programming the control panel:

- Using the built-in “Program Change” interface
- The VeriFire™ Tools Programming Utility

The benefits of each method are listed below:

Programming method	Benefits	Refer to
Program Change	Speed and convenience of putting the control panel on line quickly (using the Autoprogram function) and changing programming information.	Section “Programming” on page 14
VeriFire™ Tools Programming Utility	Efficient means of creating and editing programs that require a lot of data entry.	Product documentation & Software help file

## 1.4 Features

Programming features include the following:

- Ease-of-use – Field program the control panel without needing special software skills.
- Autoprogram option – Automatically detects newly installed, addressable devices, allowing quicker installation.
- Local programming – program directly from the control panel keypad to reduce installation time.
- PC programming – input long data entry programming information on a PC; transfer programming data between a PC and the control panel using VeriFire™ Tools programming utility.
- Security – use passwords to control access to the control panel and protect memory.
- 80-Character (2x40) Liquid Crystal Display – view programming and device information on the control panel.

## 1.5 How to Enter a Password

The control panel provides two types of selectable passwords:

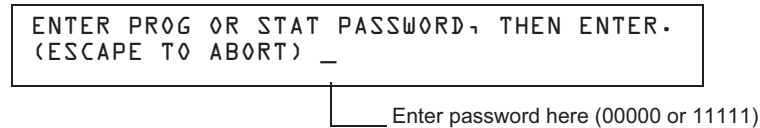
- Program Change
- Status Change

Listed below are uses and the factory-setting for each password type:

Password type	Use to	Factory Setting
Program Change (high level)	Enter Program Change option to program essential control panel functions, including basic system functions and utility options.	<b>00000</b>
Status Change (low level)	Enter Status Change option to program minor functions.	<b>11111</b>

**Table 1.4 Programming Passwords**

From the “SYSTEM NORMAL” screen: Press ENTER, press **1** (the password screen will display). Enter a password, then press ENTER



**Figure 1.1 Password Screen**

In Program Change or Status Change, the control panel does the following:

- Activates the System Trouble relay
- Shuts off the panel sounder
- Flashes the SYSTEM TROUBLE LED, which continues to flash while programming

For security purposes, passwords can be changed. To do so, follow the instructions in “Change a Password (3=passwd)” on page 26.



**NOTE:** The Read Status selection, which does not require a program password, is covered in the *NF2S-640 Operations Manual*.



**NOTE:** The NF2S-640 continues to monitor and report alarms in programming mode, except in autoprogramming.

# Section 2: Programming

## 2.1 Overview

Program Change is the programming level that lets you change the essential control panel functions, such as point programming, changing passwords, changing system functions. Included are four options: Basic Program, Network, FlashScan Poll, and Utility Program.

The structure of the Program Change option is shown below:

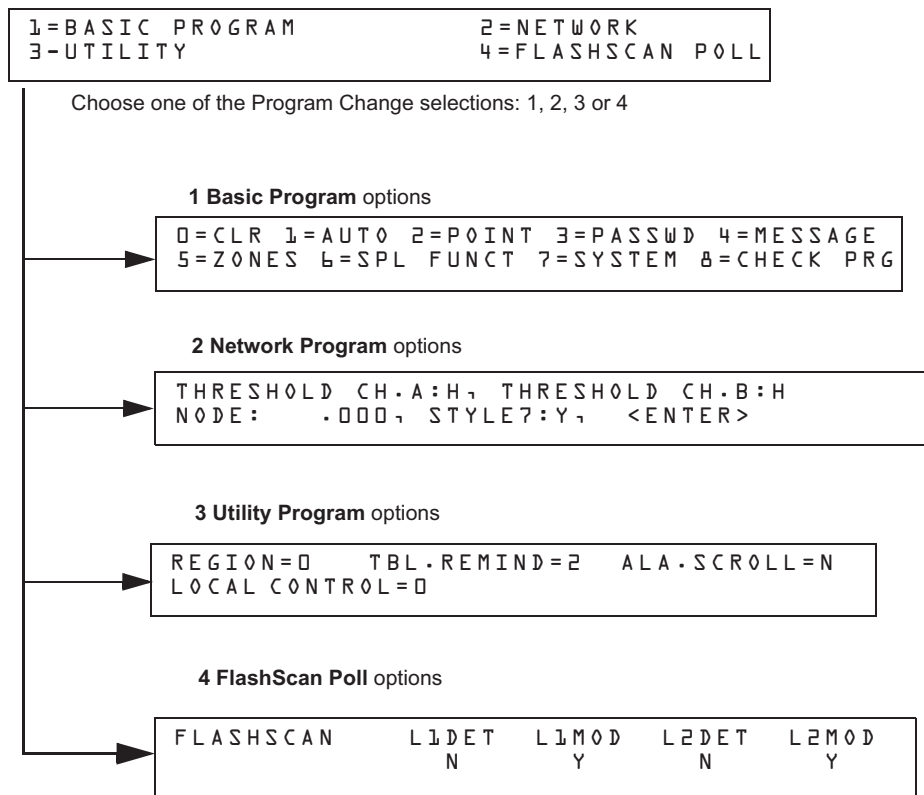


Figure 2.1 Program Change Selections

This section contains instructions and sample screens for using the Programming selections:

- **Basic Program** The Basic Program lets you program essential functions, such as clearing the program, Autoprogramming the system, programming points, and setting system functions. Refer to “Basic Program” on page 15.
- **Network Program** The Network Program allows programming of network channel thresholds, network node number, and wiring style. “The Network Program” on page 42.
- **Utility Program** The Utility Program screen provides selections for selecting a Trouble Reminder per NFPA, a Region setting, and enabling or disabling local control of the ACKNOWLEDGE/SCROLL DISPLAY, SIGNAL SILENCE, SYSTEM RESET and DRILL keys. Refer to “The Utility Program” on page 42.
- **FlashScan Poll** The FlashScan Poll screen provides the option for selecting between CLIP (Classic Loop Interface Poll) and FlashScan Poll. Refer to “FlashScan Poll” on page 44.

## 2.2 How to Enter Programming

To enter Program Change, follow these steps:

1. At the “SYSTEM NORMAL” screen, press the ENTER key. The control panel displays the “Entry” screen, as shown below:

```

1=PROGRAMMING          2=READ STATUS ENTRY
(ESCAPE TO ABORT)

```

2. At the “Entry” screen, press the 1 key. The control panel displays the “Enter Password” screen as shown below:

```

ENTER PROG OR STAT PASSWORD, THEN ENTER.
(ESCAPE TO ABORT) _

```

3. Enter your Program Change password (See “How to Enter a Password” on page 13). The control panel displays the “Program Change Selection” screen, as shown below:

```

1=BASIC PROGRAM        2=NETWORK
3=UTILITY              4=FLASHSCAN POLL

```

4. Select a Program Change selection: **1, 2, 3 or 4.**

## 2.3 Basic Program

From the “Program Change Selection” screen, press the **1** key to display the “Basic Program” screen which provides nine (9) options as shown below:

```

0=CLR  1=AUTO  2=POINT  3=PASSWD  4=MESSAGE
5=ZONES 6=SPL FUNCT 7=SYSTEM 8=CHECK PRG

```

Press the number of any one of the nine (9) options as detailed below

**Option 0=CLR** - Clears all existing user programming. For details, refer to How to Clear Memory (0=CLR) on page 16. Note: The user is prompted to double-check that this is what is really wanted.

**Option 1=AUTO** - Add or remove addressable devices to the control panel program. For details, refer to How to Autoprogram the Control Panel (1=AUTO) on page page 16.

**Option 2=POINT** - Modify or delete a point. For details, refer to “How to Modify or Delete a Point (2=POINT)” on page page 20.

**Option 3=PASSWD** - Change the Program Change or the Alter Status password. For details, refer to “How to Change a Password (3=PASSWORD)” on page page 26.

**Option 4=MESSAGE** - Edit the 40-character message that displays on the first line. For details, refer to “How to Create a System Message (4=MESSAGE)” on page page 27.

**Option 5=ZONES** - Edit the 20-character custom zone label for zones 01-99. For details, refer to “How to Create a Custom Zone Label (5=ZONE)” on page page 28.



**Option 6=SPL FUNCT** - Program Releasing Zones and Special Zones. For details, refer to “How to Program Special Zones (6=SPL FUNCT)” on page page 28.

**Option 7=SYSTEM** - Program Global System Functions. For details, refer to “How to Change Global System Functions (7=SYSTEM)” on page page 32.

**Option 8=CHECK PRG** - Check the program for errors. For details, refer to “How to Check the Program for Errors (8=check prg)” on page 41.



### 2.3.1 Clear Memory (0=CLR)


  
 Program Change  
 Password

The Clear option removes all programming information from control panel memory. If installing the control panel for the first time, use option 0 to clear control panel memory. To do so, follow these steps:





- From the “Basic Program” screen, press the **0** (zero) key to display the Clear Program screen. The control panel prompts for verification as shown below:

PRESS ENTER TO CLEAR ENTIRE PROGRAM  
OR ESCAPE TO ABORT

- Press the ENTER key to clear control panel memory or press the ESC key to exit the screen without clearing.



### 2.3.2 Autoprogram the Control Panel (1=AUTO)

#### Purpose

The Autoprogram option identifies all addressable devices connected to the control panel. Devices include addressable detectors and modules connected to SLC 1 or SLC 2, and NACs. You can use the Autoprogram option to create a new program and add or remove devices. A summary of the Autoprogram functions, when to use the functions, and where to find information on using the functions is found below:

Autoprogram Function	Control Panel Configuration	Refer to...
Create a new program for the control panel	A new control panel or a control panel with no existing program in memory.	“Create a New Program for the Control Panel” on page 16
Add one or more SLC-connected detectors and modules to an existing program	A program exists in memory and you want to add a detector or module to the existing program—without modifying information for existing detectors and modules.	“Add a Device to the Program” on page 17
Remove one or more SLC-connected detectors and modules from an existing program	A program exists in memory and you want to remove an installed detector or module from the existing program—without modifying information for existing detectors and modules.	“Remove a Device from the Program” on page 18
View system defaults	A program exists in memory and you want to view system settings assigned during Autoprogram, such as custom labels, passwords, and so on.	Page 19 “Change Autoprogram Default Value” to see the system defaults

#### Create a New Program for the Control Panel


  
 Program Change  
 Password

This section covers how to use the Autoprogram option to create a new program for the control panel. The control panel will identify all addressable detectors and modules connected to the SLC.





To create a new program for the control panel, follow these steps:

1. Use the Clear option to clear program information from memory. For instructions on clearing memory, refer to “How to Clear Memory (0=CLR)” on page page 16.



**NOTE:** Once Step 1 is completed, Step 2 will cause the panel to assess whether a loop is comprised of all FlashScan devices or not. If they are all FlashScan, autoprogramming will change the loop setting to FlashScan if it was not already at that setting. If the devices are not all FlashScan, autoprogramming will not make a change to the default setting of CLIP. (See “FlashScan Poll” on page 44 for FlashScan settings.)

2. From the “Basic Program” screen, press the **1** key to start Autoprogram. While the control panel scans the system to identify all SLC devices and NACs, it displays the following screen:

```
AUTOPROGRAM           PLEASE WAIT
```

When the autoprogram is finished identifying SLC devices and NACs, it displays a summary screen that gives a count of all the devices it has located. Refer to the following screen for an example of this display.

```
L1:010Dets, 159Mods  L2:159Dets, 159Mods
SB L1:000, L2:159    Bells: 04
```

SB represents detectors with B200 series sounder bases. Refer to VeriFire Tools for B200 sounder base programming.

3. Press ENTER. All devices are automatically accepted during initial autoprogramming. The following screen displays briefly, followed by the SYSTEM NORMAL screen.

```
ACCEPT ALL DEVICES    Please Wait!!!
```

To edit the autoprogramming default values for a point, refer to “How to Modify or Delete a Point (2=POINT)” on page 20.

To edit the autoprogram default values assigned to all modules and detectors during autoprogramming, refer to “Change Autoprogram Default Values” on page 19.

### Add a Device to the Program

You can also use the Autoprogram option to add addressable devices to the control panel program.



**NOTE:** When using the Autoprogram option with an existing program, the control panel does not change program information for installed and programmed devices. However, it will assess whether a loop contains all FlashScan devices and change the loop setting to FlashScan if necessary.

The following steps describe how to add a new detector at SLC address 1D147 with 10 detectors in the existing program:

1. Physically install the addressable detector to SLC 1 at address 147 (for instructions, refer to the *NFS2-640 Installation Manual* and the installation document that comes with the detector).
2. From the “Basic Program” screen, press the **1** key to start Autoprogram. The Autoprogram Prompt screen appears in the LCD display as the control panel identifies addressable devices. When finished identifying addressable devices, the control panel displays information for the new detector at SLC address 1D147 on the LCD display as shown below:

```
PROGRAM SMOKE (PHOTO) DETECTOR ADDR 1D147
03 _ _ _ _ _ A B P B ** 1D147
```

3. Press the ENTER key to add detector 147 to the program with the default program information. If you want to change the default information, use the programming keys to do so, then press the ENTER key to add detector 147 to the program. The Autoprogram Summary screen appears. You can verify addition of the detector to the program by noting the new count of detectors as shown below:

Note that the number of detectors increases (in this example from 10 to 11) to show the addition of the detector to SLC 1.

```
L1:011Dets, 159Mods L2:159Dets, 159Mods
SB                      Bells: 04
```

4. Press the ENTER key, then press the esc key to save the program in memory and return to the “Basic Program” screen).

### Remove a Device from the Program

You can also use the Autoprogram option to remove addressable detectors and modules from the control panel program.



**NOTE:** When using the Autoprogram option with an existing program, the control panel does not change program information for installed and programmed devices.

The following steps describe how to delete a detector at SLC address 1D133 with 11 detectors connected to SLC 1 in the existing program:

1. Disconnect and remove the detector from SLC 1 at address 1D133.
2. From the “Basic Program” screen, press the 1 key to start Autoprogram. The Autoprogram Prompt screen displays while the control panel identifies addressable devices.
3. When finished identifying addressable devices, the control panel displays a screen, indicating a missing detector at SLC address 1D133 as shown below:

```

Type Code
┌───────────┴───────────┐
PROGRAM SMOKE (ION) DETECTOR ADDR 1D133
DEVICE NOT ANSWERING DELETE FR MEM?1D133
└───────────┬───────────┘
              SLC loop number
              D (detector) or M (module)
              Three-digit address (001-159)

```

4. Press the ENTER key to delete detector 1D133 from the program. The Autoprogram Summary screen appears. You can verify removal of the detector from the program by noting the new count of detectors as shown below:


Note that the number of detectors decreases (from 11 to 10) to show the removal of the detector from SLC 1.

```
L1:010Dets, 159Mods L2:159Dets, 159Mods
SB                      Bells: 04
```

5. Press the ENTER key, then press the ESC key to save the program in memory and return to the “Basic Program” screen.

## Change Autoprogram Default Values

To assign system default values from the basic program screen, Press **0** (clear), then press **1** (autoprogram). Refer to the chart below for default values and how to modify them.

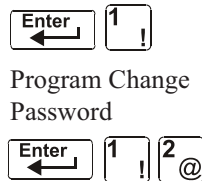
Function	Default Values	To Alter, refer to
Software Zones 01-99	Default custom label "Zone xx" where xx is the number of the zone <b>Note:</b> Zone 00 is reserved for a general alarm.	"How to Create a Custom Zone Label (5=ZONE)" on page 28
F0	PRG PRESIGNAL FUNCT PRESIGNAL DELAY DELAY=180 PAS=NO F00	"F0 (Presignal/PAS) The Presignal screen provides fields for changing the delay time or PAS. For details on Presignal selections, refer to "Presignal and Positive Alarm Sequence (PAS)" on page 87. From the Special Function Change screen, press the F key, then press the 0 key to display the Presignal Function screen." on page 30
Releasing Zones R0-R9	PRG RELEASE FUNCT RELEASE CONTROL DELAY=00 ABORT=ULI CROSS=N SOK=0000	"R0-R9 (Releasing Functions) The Releasing Function screen provides fields for changing releasing functions: Delay Timer, Abort Switch, Cross Zone, and Soak Timer. For details on releasing applications, refer to "NFPA Releasing Applications" on page 55." on page 30 and "How to Program a Releasing Zone" on page 56.   <b>NOTE:</b> The FCM-1-REL has an inherent two second delay, which must be factored into the DELAY TIME and SOK (soak time) entries.
F5 and F6	PRG TIME FUNCTION TIME CONTROL ON=**.** OFF=**.** DAYS=*****	"F5-F6 (Time Control Functions) The Time Control screen provides fields for changing the start time, stop time, or days of the week. For details on time selections, refer to "Time Control Zones" on page 88. From the Special Function Change screen, select F5 or F6 to display the Time Control screen:" on page 30
F7	PRG HOLIDAY FUNCTION **/** **/** **/** **/** **/** **/** **/** **/** **/**	"F7 (Holiday) The Holiday screen provides fields for specifying up to nine holiday dates. For details on holiday selections, refer to "Time Control Zones" on page 88. From the Special Function Change screen, press F7 to display the Holiday screen:" on page 31
F8	PRG CODING FUNCTION CODE TYPE MARCH TIME F08	"F8 (Coding Function) The Coding Function screen provides fields for specifying one of seven coding functions: March Time, Two-stage, California, Temporal, Canadian Two-Stage (3 minutes), Canadian Two-Stage (5 minutes), System Sensor Strobe, Gentex Strobe, and Wheelock Strobe. For details on selecting coding functions, refer to "Coding Functions for NACS" on page 88. From the Special Function Change screen, press F8 to display the Coding Function screen:" on page 31
F9	PRE-ALARM FUNCT ALERT F09	"F9 (Pre-Alarm) The Pre-Alarm screen provides fields for programming the Alert or Action Pre-Alarm functions. For details on Pre-Alarm selections, refer to "How to Select a Pre-Alarm Level" on page 95. From the Special Function Change screen, press F9 to display the Pre-Alarm screen:" on page 31
System Parameters	SIL INH=0000 AUTO=0077 0 VERIFY=30 USA TIME TERM=N AC_DLY=Y LocT BLINK=01 ST=4 ACS=N	"How to Change Global System Functions (7=SYSTEM)" on page 32
Passwords	Default programming passwords are: Program Change=00000 Status Change=11111	"How to Change a Password (3=PASSWD)" on page page 26
SYSTEM NORMAL message	(YOUR CUSTOM SYSTEM MESSAGE HERE) SYSTEM NORMAL 10:23A 041508 Tue A message, along with the current day, time, and date, that displays on the second line of the LCD display during normal operation.	<b>Note:</b> The second line, "SYSTEM NORMAL", is a standard system message that you cannot change
System Message	(YOUR CUSTOM SYSTEM MESSAGE HERE) SYSTEM NORMAL 10:23A 041508 Tue The first line of the LCD display contains 40 blank characters for a custom message.	"How to Create a System Message (4=MESSAGE)" on page page 27

**Table 2.1 Autoprogram Defaults (1 of 2)**

Function	Default Values	To Alter, refer to
IP ACCESS	Default setting is zero (0), IP Access not enabled.	"The Utility Program" on page 42
DCC Mode	Default setting is N, no DCC participation.	"The Utility Program" on page 42

Table 2.1 Autoprogram Defaults (2 of 2)

### 2.3.3 Modify or Delete a Point (2=POINT)

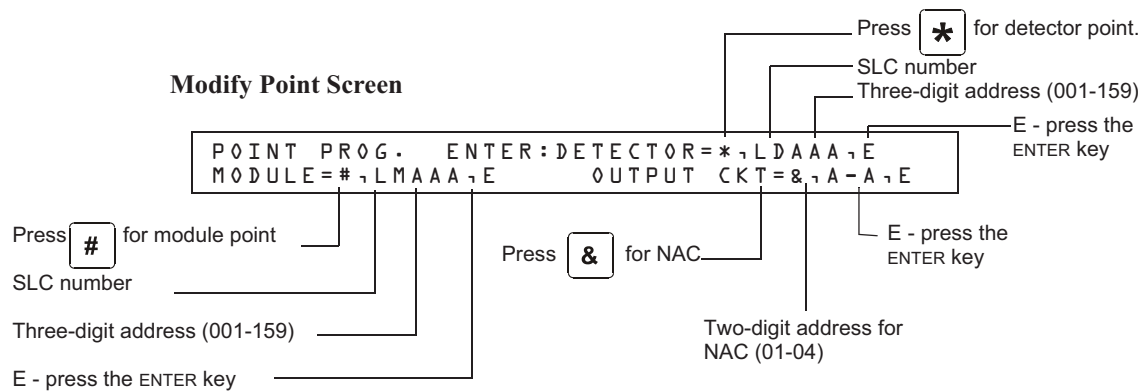


After programming all SLC-connected devices into the system, you can modify or delete points. From the "Basic Program" screen, press the 2 key to display the Point Programming screen:

```
POINT PROG.          1=MODIFY POINT
2=DELETE POINT
```

To modify a point for a detector, module, or NAC: press the 1 key to display the "Modify Point" screen.

To delete a point for a detector, module, or NAC: press the 2 key to display the "Delete Point" screen.



**Delete Point Screen**

```
DELETE POINT.  ENTER: DETECTOR=* 1 L D A A A 1 E
MODULE=# 1 L M A A A 1 E      OUTPUT CKT=# 1 A - A 1 E
```

The Modify Point and Delete Point screens let you edit or delete points for a detector, a monitor or control module, or NAC. To select a point, follow these steps:

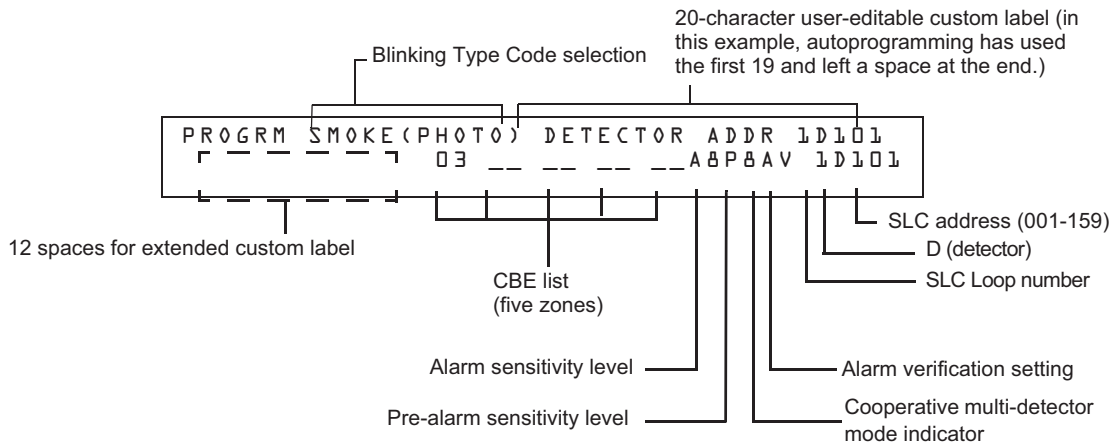
To select	Do the following	Refer to
an addressable detector	Press * Type the SLC number (1 or 2) and detector (D) and address (001-159) Press Enter	"Modify an Addressable Detector Point" on page 21.
an addressable monitor module	Press # Type the SLC number (1 or 2) and module (M) and address (001-159) Press Enter	"Modify an Addressable Monitor Module Point" on page 22.

To select	Do the following	Refer to
an addressable control module	Press <b>#</b> Type the SLC number (1 or 2) and module (M) and address (001-159) Press <b>Enter</b>	"Modify an Addressable Control Module Point" on page 23.
a NAC	Press <b>&amp;</b> Type the NAC address (01-04) Press <b>Enter</b>	"Modify NAC Points" on page 25.

The next four sections describe how to program the points selected.

### Modify an Addressable Detector Point

This section contains a sample detector programming screen, detector default selection, and instructions for modifying a detector point. Autoprogram default values for a detector are shown:



Field	Description	Set as Follows
Type Code	Detector function specification - SMOKE(PHOTO) in example.	Press the NEXT or PREVIOUS Selection keys to scroll through valid detector Type Code selections. See 9.4 on page 108 for lists and descriptions.
Custom Label	20 character custom label.	Change by placing the cursor into the first space of the field using the arrow keys, then typing the descriptor. DETECTOR ADDR 1D101 is the autoprogram default custom label for the detector at address 101 on SLC 1.
Extended Label	12 character custom label extension.	See "Custom Label" above. Note that spaces must be input by the user, including any space necessary between the custom and extended label fields. An 80-column printout will run the two fields together.
CBE List	Five zones can be listed - one zone, Z03, is shown in the example. Up to 4 more could be added to this detector.	Zones can be changed or added to the CBE list by placing the cursor in the zone field using arrow keys, then typing. Defaults: Zone 01 (Heat detectors) Zone 02 (Ion detectors) Zone 03 (Photo detectors, Beam detectors) Zone 04 (Laser detectors) Zone 05 (Multisensor)

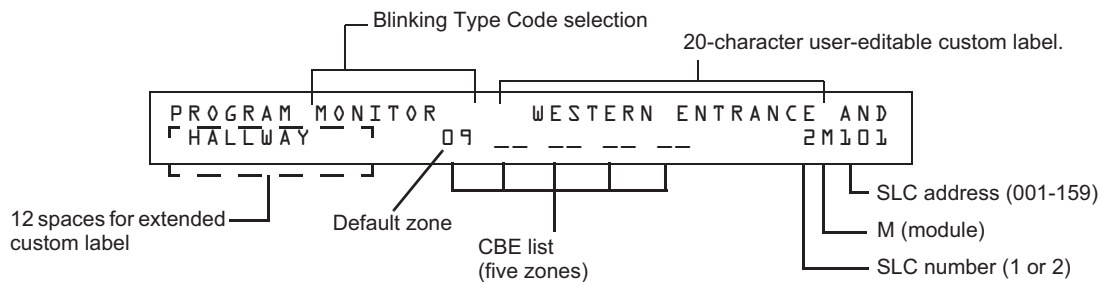
**Table 2.2 Detector Program Values**

Field	Description	Set as Follows
Alarm Sensitivity	The alarm sensitivity level, with 9 the least sensitive alarm level and 1 the most sensitive alarm level.	Refer to Table 6.2 on page 97 for settings. Select by placing the cursor in the field using the arrow keys, then either pressing the NEXT or PREVIOUS keys to make the selection, or typing the value. Defaults: A8 (Photo) A6 (Ion) A6 (Laser ) A5 (Multisensor )
Pre-alarm level	Shows the Pre-Alarm level setting—a number between 0 and 9—as follows: 0 – no Pre-Alarm 1 – self optimizing 2 – most sensitive Pre-Alarm level 9 – least sensitive Pre-Alarm level	Refer to Table 6.2 on page 97 for settings. Select by placing the cursor in the field using the arrow keys, then either pressing the NEXT or PREVIOUS keys to make the selection, or typing the value. Defaults: P8 (Photo) P6 (Ion) P6 (Laser) P5 (Multisensor)
Cooperative Multi-detector mode	Indicates the cooperative multi-detector mode (A in the example).	Select by placing the cursor in the field using the arrow keys, then either pressing the NEXT or PREVIOUS keys to make the selection, or typing the value. * = OFF (Default) A combines the detector's alarm decision with the next address above B combines the detector's alarm decision with the next address below C combines the detector's alarm decision with the next address above and the next address below
Alarm verification	Indicates the alarm verification setting (V in the example).	Indicates Alarm Verification (V=on, *=off). Select by placing the cursor in the field using the arrow keys, then pressing the NEXT or PREVIOUS keys to make the selection. Refer to “Interpreting a Detector Status Display or Maintenance Report” on page 100 for more information on the alarm verification feature. Note: Do not use this setting when an alarm activation requires activation of two or more automatic detection devices.

**Table 2.2 Detector Program Values**

### Modify an Addressable Monitor Module Point

When you select a point address, the control panel returns a screen that displays information about the point. Below is an example of information for a monitor module (2M101) in the LCD display:



Field	Description	Set as Follows
Type Code	Monitor Module function specification - MONITOR in example.	Press the NEXT or PREVIOUS Selection keys to scroll through valid monitor module Type Code selections. Lists and descriptions are in See Table 9.2 on page 110.

**Table 2.3 Modifying Monitor Module Programming Selections (1 of 2)**



Field	Description	Set as Follows
Custom Label	20 character custom label.	Change by placing the cursor into the first space of the field using the arrow keys, then typing the descriptor. Note: Spaces must be input by the user, including any space necessary between the custom and extended label fields. An 80-column printout will run the two fields together.
Extended Label	12 character custom label extension.	See "Custom Label" above.
CBE List	Five zones can be listed - one zone, Z09, is shown in the example. Up to 4 more could be added to this module.	Zones can be changed or added to the CBE list by placing the cursor in the zone field using arrow keys, then typing. See Table 2.4 on page 23 for defaults.

**Table 2.3 Modifying Monitor Module Programming Selections (2 of 2)**

When finished modifying a point, press the ENTER key; then press the NEXT or PREVIOUS key to select another point.

### Monitor Module Default Zone Assignments

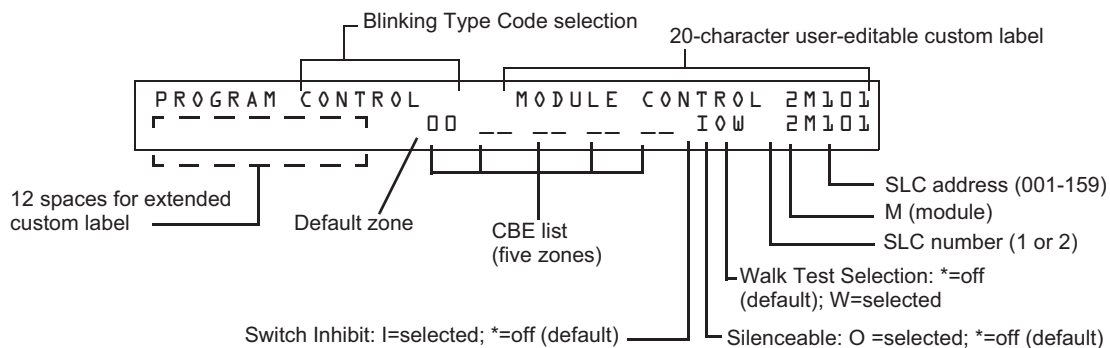
Listing of the monitor module address range and the default zone assignment for each range:

Monitor Module Address	Zone Default
01 through 19	Z04
20 through 39	Z05
40 through 59	Z06
60 through 79	Z07
80 through 99	Z08
100 through 119	Z09
120 through 139	Z10
140 through 159	Z11

**Table 2.4 Monitor Module Default Zones**

### Modify an Addressable Control Module Point

When you select a point address for modification, the control panel returns a screen that displays information about the point. For example, the illustration below shows sample information for a control module (2M101) in the LCD display.



**NOTE:** On a control module, the default zone is always set to Zone 00 (general alarm).

To modify a point, follow these steps. A blinking cursor indicates the selected field.

1. From the programming screen, use the arrow keys to move to a field that you want to modify. See below for descriptions and settings.

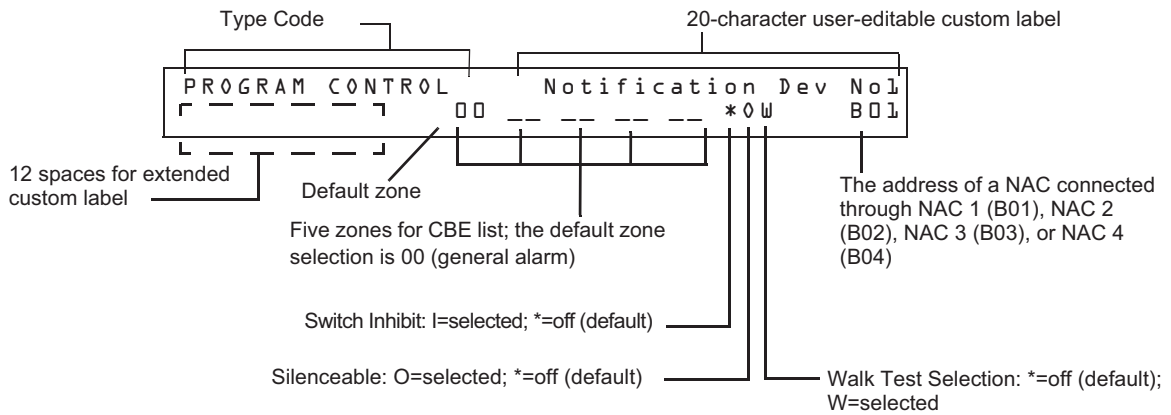
Field	Description	Set as follows:
Type Code	Specifies the function of the control module	Press the NEXT or PREVIOUS Selection keys to scroll through valid control module Type Code selections (listed in Table 9.3 on page 112)
Custom Label	20 character custom label.	Change by placing the cursor into the first space of the field using the arrow keys, then typing the descriptor. Note: Spaces must be input by the user, including any space necessary between the custom and extended label fields. An 80-column printout will run the two fields together.
Extended Label	12 character custom label extension.	See "Custom Label" above.
CBE list	Up to five software zones can be entered to define the output responses of the control module based on various initiating conditions (events)	Type the number of up to five zones, including E0-E9, F0-F9, L0-L9, R0-R9, and zones 00-99. The first zone default is Z00 (general alarm).
Switch Inhibit	Specifies if an operator can manually activate an output	Type one of the following entries. I = Switch Inhibit enabled * = no switch inhibit (default for all but releasing circuits)
Silenceable	Specifies if an operator can manually silence an activated output	Type one of the following entries. * = output nonsilenceable F = silenceable, resound by fire alarm U = silenceable, resound by supervisory alarm B = silenceable, resound by security alarm T = silenceable, resound by trouble O = silenceable, does not resound If the "Strobe" Type ID is used with System Sensor, Gentex or Wheelock Strobe synchronization, "*" will silence the horn portion only, and resound will occur only by fire alarm. F, U, B, T, or O will silence the entire circuit, and resound will occur according to the above definitions.
Walk Test	Specifies if outputs sound during Walk Test	Type one of the following entries. W = devices sound (Basic Walk Test) * = devices do not sound (Silent Walk Test) (default)

**Table 2.5 Modifying Control Module Programming Selections**

2. When finished modifying a point, press the ENTER key; then press the NEXT or PREVIOUS key to select another point.

### Modify NAC Points

Modifying NACs (four NACs on the NFS2-640) is like modifying control modules—except for the Type Code and device address.



To modify a point, follow these steps. A blinking cursor indicates the selected field.

1. From the programming screen, use the arrow keys to move to a field that you want to modify and refer to information below for descriptions and settings.

Field	Description	Set as follows:
Type Code	Specifies the function of the NAC.	Press the NEXT or PREVIOUS Selection keys to scroll through the NAC Type Code selections (listed in Table 9.4 on page 112)
Custom Label	20 character custom label.	Change by placing the cursor into the first space of the field using the arrow keys, then typing the descriptor. Note: Spaces must be input by the user, including any space necessary between the custom and extended label fields. An 80-column printout will run the two fields together.
Extended Label	12 character custom label extension.	See "Custom Label" above.
CBE zones	Specifies up to five software zones to define the output responses of the NAC based on various initiating conditions (events)	Type the numbers of up to five zones, including E0-E9, F0-F9, L0-L9, R0-R9, and zones 00-99. The first zone default is 00 (general alarm)
Switch Inhibit	Specifies if an operator can manually activate an output	Type in one of the following values. I = Switch Inhibit enabled * = Switch Inhibit disabled (default for all but releasing circuits)



**Table 2.6 Modifying a NAC Programming Selections (1 of 2)**

Field	Description	Set as follows:
Silenceable	Specifies if an operator can manually silence an activated output	Type in one of the following values. * = output nonsilenceable <b>F</b> = silenceable, resound by fire alarm <b>U</b> = silenceable, resound by supervisory alarm <b>B</b> = silenceable, resound by security alarm <b>T</b> = silenceable, resound by trouble <b>O</b> = silenceable, does not resound If the "Strobe" Type ID is used with System Sensor, Gentex or Wheelock Strobe synchronization, "*" will silence the horn portion only, and resound will occur only by fire alarm. F, U, B, T, or O will silence the entire circuit, and resound will occur according to the above definitions.
Walk Test	Specifies if outputs sound during Walk Test	Type in one of the following values. <b>W</b> = devices sound (Basic Walk Test) - default * = devices do not sound (Silent Walk Test)

**Table 2.6 Modifying a NAC Programming Selections (2 of 2)**

- When finished modifying a point, press the ENTER key; then press the NEXT or PREVIOUS key to select another point.

### 2.3.4 Change a Password (3=PASSWD)


  
 Program Change  
 Password

Password Change lets you select a custom Program Change (high level) or Status Change (low level) password. From the "Basic Program" screen, press the 3 key to display the "Change Password" screen.









```

CHANGE PASSWORD      * , NNNNN , E = PROGRAM
# , NNNNN , E = STATUS
    
```

Entry area for new password

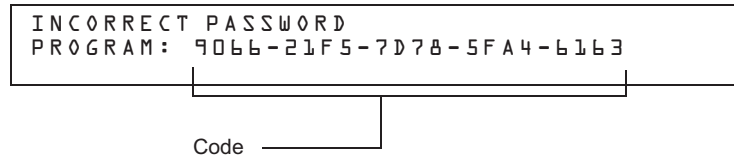
To change a password, follow the instructions below:

To	Press	Then
Change the Program Change password		Enter the new Program Change password. Use five digits, no characters.
Change the Status Change password		Enter the new Status Change password. Use five digits, no characters.
Save the password		The Verify Password screen appears. Press ENTER to verify.
Leave the Change Password screen without changing a password		The Basic Program screen appears.

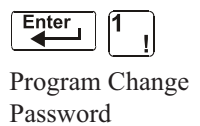
**Table 2.7 Changing a Password**

### A Forgotten Password?

If a password is entered incorrectly, the panel will respond by displaying an INCORRECT PASSWORD message and a code. The programmer may hit escape and reenter the password correctly. However, if the password has been forgotten, record the code and contact Notifier. After proper authentication, the original password can be determined by deciphering the code. An example of an INCORRECT PASSWORD display is given below:



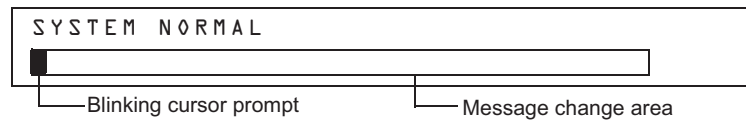
## 2.3.5 Create a System Message (4=MESSAGE)



The Message option lets you create a 40-character custom System Message that displays on the first line of the “SYSTEM NORMAL” screen as shown below:



From the “Basic Program” screen, press the 4 key to display the “System Message Change” screen:



To create the system message, follow these guidelines:



- Enter one character at a time, indicated by the blinking cursor on the second line of the display.
- Enter up to 40 characters maximum.

Instructions for entering characters in the Message Change screen:

To	Do this
Change a blinking character	Enter a character from the keypad
Move to the next character	Press
Enter lower case characters	Press  , then press the character of your choice.
Enter additional characters ! @ = , % : \ .   ?	Press  , then press a number key as follows:  For example, press  , then press the 3 () key to enter a “=” character.
Save the new message	Press


Table 2.8 Creating Messages

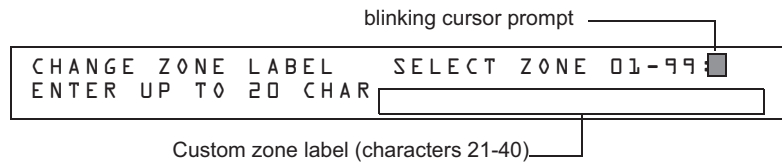
### 2.3.6 Create a Custom Zone Label (5=ZONE)


  
 Program Change  
 Password

The Zone option lets you change the custom label assigned to zones 1-99. From the “Basic Program” screen, press the **5** key to display the “Zone Change” screen as shown below:









The zone number displays in the first line, characters 39 and 40. When changing a zone label, follow these guidelines.



- For single-digit numbers, enter a leading zero before the digit.
- Enter an alphanumeric zone label into line 2, characters 21–40.

To change a custom label for a zone, follow these instructions:

To	Do this
Change a zone label	Enter a new zone label from the keypad.
Save the zone label in memory	Press  . The program stores the zone label in memory and displays the Zone Change screen with all fields blank.
Leave the Zone Change screen without changing a zone label	Press  . The display returns to the Program Change screen.

**Table 2.9 Create or Change a Custom Zone Label**

### 2.3.7 Program Special Zones (6=SPL FUNCT)


  
 Program Change  
 Password

The Special Zone Change option lets you change the program for Special Zones F0-F9, Releasing Zones R0-R9, FA (Verification) or FB (Custom drill zone). From the “Basic Program” screen, press the **6** key to display the “Special Function Change” screen as shown below:





```
SPECIAL FUNCTION: F0=PRESIG R0-R9=REL
F5-F6=TIME F7=H0L F8=CODE F9=PRE-ALARM
```

#### Special Zone Descriptions

Descriptions for each Special Zone that appears in the “Special Function Change” screen are detailed below:



**NOTE:** Special Zones F0-F9 appear in the CBE list of a device as ZF0-ZF9. For example, if you list F0 for a detector, one of the five zones in the CBE list of the detector will display as ZF0.

Special Zone	Lets you
F0=PRESIG	Select a Presignal Delay Timer and select PAS (Positive Alarm Sequence)
F5-F6=TIME	Specify Time Control functions such as the start time, stop time, or days of the week
F7=HOL	Specify up to nine holiday dates. An F7-programmed device activates on the specified holiday dates
F8=CODE	Specify one of nine coding function selections: March Time, Temporal, California, Two-Stage, Canadian Two-Stage (3 minute or 5 minute), System Sensor Strobes, Gentex Strobes, or Wheelock Strobes. F8 only takes effect if you program one or more NACs to F8
F9=PRE-ALARM	Select a Pre-Alarm level: Alert or Action
FA	Turn on when detector in verification mode. This is a fixed point and is not programmable
FB	Turn on if custom drill set to Y and the panel in Drill mode
R0-R9=REL	Program up to ten Releasing Zones, each with a selection for a Delay Timer, an Abort Switch, a Cross Zone selection, or a Soak Timer

**Table 2.10 Summary of Special Zones**

The control panel also provides four Special Zones, F1-F4, which are outputs that do not appear on the Special Function Change screen. You can program Special Zones F1 to F4 into the CBE of an output device. Descriptions of F1, F2, F3, and F4 are detailed below:

To view the status of Special Functions F1-F4, use the Read Status function (refer to the *NFS2-640 Operations Manual*).

Special Function	Specifies
F1 (Trouble less AC)	An output programmed to turn on/off if a system trouble—other than an AC power loss—occurs
F2 (AC Trouble)	An output programmed to turn on/off if an AC power loss or a brownout condition occurs
F3 (Security)	An output programmed to turn on/off if a Security input activates
F4 (Supervisory)	An output programmed to turn on/off if a Supervisory input activates

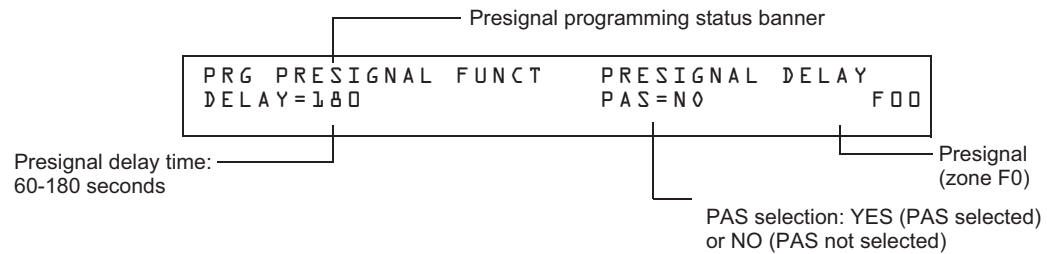
**Table 2.11 Special Output Functions F1-F4**

### Selecting Special Zones

Select Special Zones by entering the Special Zone letter and number (for example, F0, R0, and so on) from the Special Function Change screen. The following sections show sample screens that display when you select a Special Zone.



**F0 (Presignal/PAS)** The Presignal screen provides fields for changing the delay time or PAS. For details on Presignal selections, refer to “Presignal and Positive Alarm Sequence (PAS)” on page 88. From the Special Function Change screen, press the **F** key, then press the **0** key to display the Presignal Function screen.

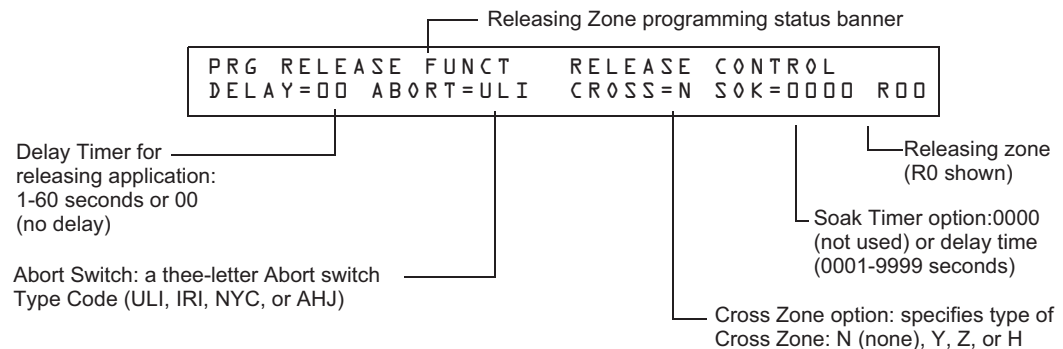


**R0-R9 (Releasing Functions)** The Releasing Function screen provides fields for changing releasing functions: Delay Timer, Abort Switch, Cross Zone, and Soak Timer. For details on releasing applications, refer to “NFPA Releasing Applications” on page 56.

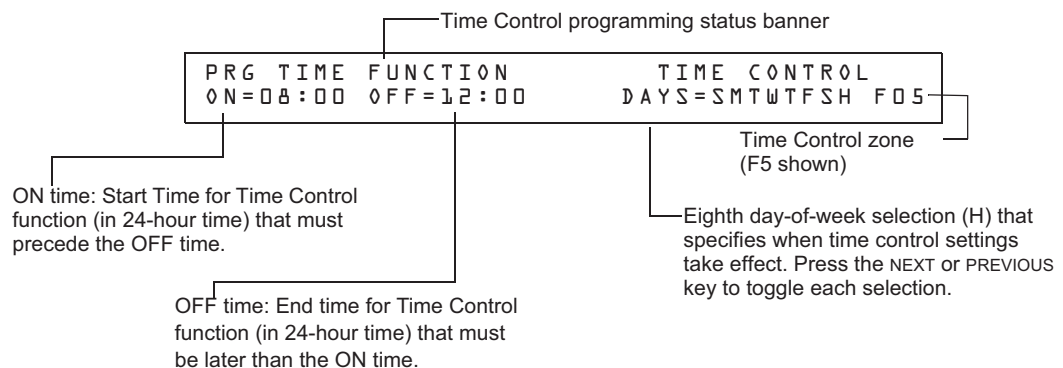


**NOTE:** The FCM-1-REL has an inherent two second delay, which must be factored into the DELAY TIME and SOK (soak time) entries.

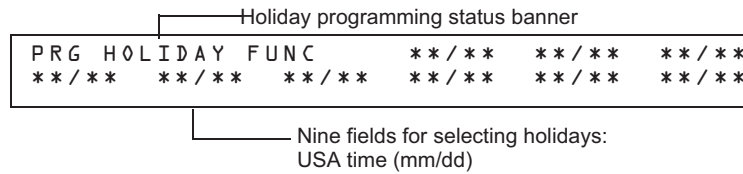
From the Special Function Change screen, select a function (R0-R9) to display the Releasing Function screen:



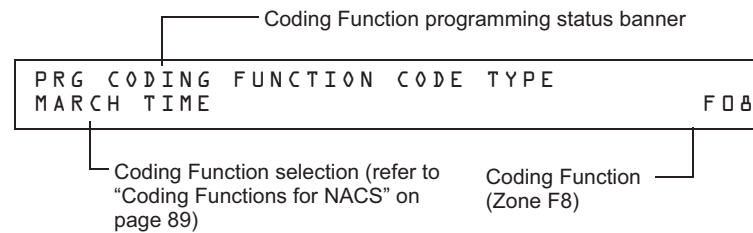
**F5-F6 (Time Control Functions)** The Time Control screen provides fields for changing the start time, stop time, or days of the week. For details on time selections, refer to “Time Control Zones” on page 89. From the Special Function Change screen, select F5 or F6 to display the Time Control screen:



**F7 (Holiday)** The Holiday screen provides fields for specifying up to nine holiday dates. For details on holiday selections, refer to “Time Control Zones” on page 89. From the Special Function Change screen, press **F7** to display the Holiday screen:



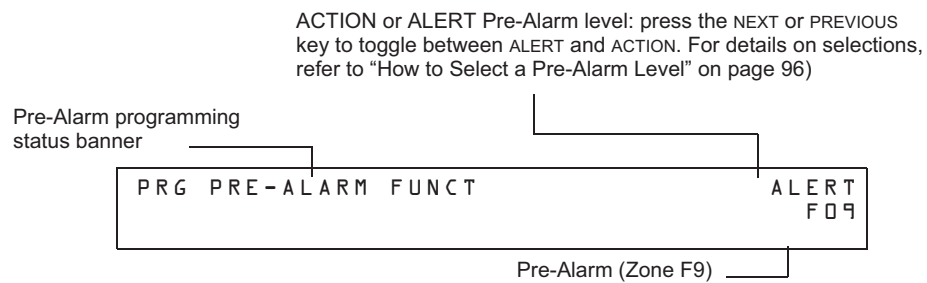
**F8 (Coding Function)** The Coding Function screen provides fields for specifying one of seven coding functions: March Time, Two-stage, California, Temporal, Canadian Two-Stage (3 minutes), Canadian Two-Stage (5 minutes), System Sensor Strobe, Gentex Strobe, and Wheelock Strobe. For details on selecting coding functions, refer to “Coding Functions for NACS” on page 89. From the Special Function Change screen, press **F8** to display the Coding Function screen:



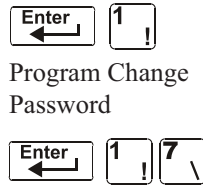
**F9 (Pre-Alarm)** The Pre-Alarm screen provides fields for programming the Alert or Action Pre-Alarm functions. For details on Pre-Alarm selections, refer to “How to Select a Pre-Alarm Level” on page 96. From the Special Function Change screen, press **F9** to display the Pre-Alarm screen:

**FA (Verification)** Turn on when detector in verification mode. This is a fixed point and is not programable.

**FB (Custom drill zone)** Turn on if custom drill set to Y and the panel in Drill mode. FA and FB can map to output point only. It can be mapped to the output device as a CBE using either panel key pad or VeriFire tools. But the custom drill option (Yes or No) is only programmed by VeriFire tools.



### 2.3.8 Change Global System Functions (7=SYSTEM)



Program Change Password

The System option lets you select settings for global system functions that apply to all programmed devices and zones. For instance, selecting an Alarm Verification Timer for 30 seconds means that all initiating devices selected for Alarm Verification use a 30-second timer. From the “Basic Program” screen, press the 7 key to display the “System Function” screen as shown below:

```
SIL INH=000 AUTO=000 VERIFY=30 USA TIME
TERM=N AC_DLY=Y LocT BLINK=01 ST=4 ACS=N
```

#### Global System Functions

Settings for global system functions:

System Function	Setting	Default
SIL INH (Silence Inhibit Timer)	0 to 300 seconds	000
AUTO (Auto Silence Timer) - After the time delay expires, functions like pressing the SIGNAL SILENCE key, silencing active outputs programmed as silenceable.	000 (none); 600 to 900 seconds	000
VERIFY (Alarm Verification Timer)	0 to 60 seconds*	60
USA TIME	USA time (mm/dd/yy) or EUR time (dd/mm/yy) Press the NEXT or PREVIOUS key to change. Note that (European) time changes to 24-hour time format and date format.	USA
TERM - Allows supervision for devices connected to TB11, i.e., FDU-80.	N = no supervision Y = supervision enabled	N
AC_DLY**	AC delay – delays loss of AC reporting for 3 hours. Y=AC delay; N=no AC delay	Y
LocX - One of three operating modes of PC or terminal connected to the control panel through TB12 on the CPU2-640.  <b>Note:</b> For a complete list of functions, refer to the <i>NFS2-640 Operations Manual</i> .	LocT -(terminal connected to control panel and located in same room). LocM -(same as LocT but requires password). RemT -(terminal connected through a modem for Read Status only).	LocT
BLINK - Addressable SLC device LED blink.	Select from 00 to 16. (00 = no blink, 01 = blink every poll, 02 = blink every 2nd poll, 03 = blink every 3rd poll up to 16 = blink every 16th poll). Note that this setting affects FlashScan modules only.	01
ST - The NFPA wiring style used for the SLC.	6=Style 6 SLC wiring 4=Style 4 SLC wiring	4
ACS - Use ACS Selection Groups (Refer to “Annunciator Options” on page 33).	N or Y	N

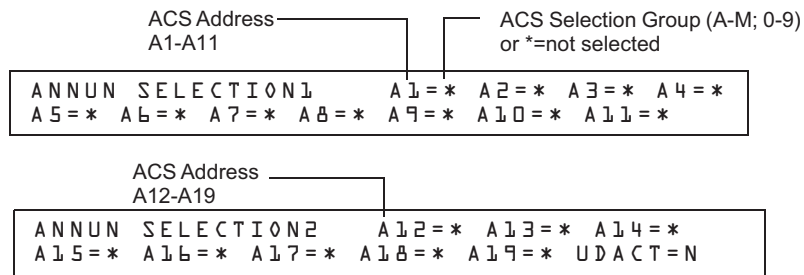
Table 2.12 Settings for Global Systems Functions (1 of 2)

System Function	Setting	Default
<p>*This value can not exceed 30 seconds for ULC installations.                      **The onboard trouble relay will activate (TB4 on the NFS2-640 CPU) and TM-4s will report according to this setting. UDACTs are notified immediately of AC failure by the panel, regardless of the panel's delay setting. Once the UDACT receives notification, it operates according to its own programmed AC Fail Delay reporting schedule.</p> <p><b>Example:</b> AC Failure occurs at 1:00 p.m. on a panel with an AC_DLY setting of Y (3 hours). The UDACT is set for notification after 1 hour.                      1:00 p.m. - AC Failure. Panel notifies UDACT. Panel and UDACT timers begin countdown to report time.                      2:00 p.m. - UDACT reports.                      4:00 p.m. - TM-4 reports, TB4 trouble relay activates.</p> <p>The ACPS-610, ACPS-2406, and XPIQ power supplies must be set to an AC Delay value of 0 (zero) when used with this panel.</p>		

**Table 2.12 Settings for Global Systems Functions (2 of 2)**

**Annunciator Options**

Use Annunciator Selection screens to select information that will display on the ACS annunciators. (Table 2.13 on page 34 contains the ACS display selections.) Setting ACS=Y from the “System Function” screen displays the Annunciator Selection 1 screen, address A1 - A11. Press enter to display Annunciator Selection 2 screen, address A12 - A19:



If UDACT=Y: Addresses A20-A32 are available with UDACTs having software release #UDACT02.1 or higher to send control panel status to the UDACT.  
 If UDACT=N: The control panel displays the Annunciator Selection 3 & 4 screen addresses A20-A32.

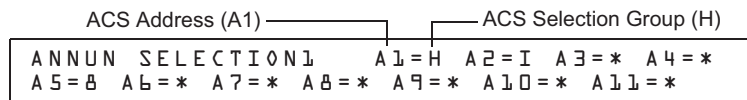
Enter “N” (ACS Selection Group N) for a TM-4 module used for remote station communication.

Enter “O” (ACS Selection Group O) for a TM-4 used as a municipal box trip. This will provide a “Master Box” trouble message at the panel.

Refer to page page 41 for further information on Group N and Group O.

**ACS Selection Group Example**

An example of a screen listing ACS Selection Groups (H, I and M):



Annunciator selections for addresses A1, A2 and A3 (addresses A4-A11 not selected).

- Annunciators set to Address 1 display the status of detectors 1-64 (Group H) on SLC 1
- Annunciators set to Address 2 display the status of detectors 1-64 (Group I) on SLC 2

## Annunciation Points

The control panel's annunciation points are divided into 23 ACS selection groups of 64 points each. The table below contains a list of these groups, what an annunciator displays when a group is selected, and where to locate a definition of the 64 points within the group.

ACS Selection Group	Annunciator Display	Refer to
A	8 System points & Zones 1 - 56	Table 2.14 on page 35
B	Zones 57 - 99, 9 F Zones, 8 R Zones, 4 NACs	Table 2.15 on page 36
C	Loop 1, Modules 1 - 64	Table 2.16 on page 36
D	Loop 2, Modules 1 - 64	Table 2.17 on page 37
E	Loop 1, Modules 65 - 128	Table 2.18 on page 37
F	Loop 2, Modules 65 - 128	Table 2.19 on page 37
G	Loop 1, Modules 129 - 159 (1 unused point) Loop 2, Modules 129 - 159 (1 unused point)	Table 2.20 on page 37
H	Loop 1, Detectors 1 - 64	Table 2.21 on page 38
I	Loop 2, Detectors 1 - 64	Table 2.22 on page 39
J	Loop 1, Detectors 65 - 128	Table 2.23 on page 39
K	Loop 2, Detectors 65 - 128	Table 2.24 on page 39
L	Loop 1, Detectors 129 - 159 (1 unused point) Loop 2, Detectors 129 - 159 (1 unused point)	Table 2.25 on page 40
M	Programmable for use with FireVoice NFV-25/50ZS	Table 2.26 on page 40
N	8 System Points & Zones 1-56	"ACS Selection Group N" on page 41
O	8 System Points & Zones 1-56	"ACS Selection Group O" on page 41
1	Programmable Annunciator #1	See Note
2	Programmable Annunciator #2	See Note
3	Programmable Annunciator #3	See Note
4	Programmable Annunciator #4	See Note
5	Programmable Annunciator #5	See Note
6	Programmable Annunciator #6	See Note
7	Programmable Annunciator #7	See Note
8	Programmable Annunciator #8	See Note
9	Programmable Annunciator #9	See Note
0	Programmable Annunciator #10	See Note

**Table 2.13 ACS Selection Groups**



**NOTE:** Refer to the VeriFire™ Tools programming utility for programming these annunciators.

**ACS Selection Group A:**

Point	Type	Red LED	Yellow LED	Switch Function*
1	Input	System Alarm	System Trouble	Acknowledge
2	Output	Not Used	Signal Silenced	Alarm Silence
3	Output	Not Used	Program Mode	System Reset
4	Output	Not Used	Supervisory	Drill
5	Output	NAC #1 Active	NAC Trouble	Control NAC #1
6	Input	Security	P/A Maint. Alert	Not Used
7	Input	Not Used	Low Battery	Not Used
8	Input	Not Used	AC Fail	Not Used
9	Input	Zone 1 Active	Zone 1 Trouble	Not Used
10	Input	Zone 2 Active	Zone 2 Trouble	Not Used
11	Input	Zone 3 Active	Zone 3 Trouble	Not Used
to		to (see note)	to (see note)	
64	Input	Zone 56 Active	Zone 56 Trouble	Not Used

\* Pressing the switch button when the Switch Function is "Not Used" will cause the associated LED to stop blinking. This is a local acknowledgement at the annunciator only; no message is sent to the panel.

**Table 2.14 ACS Group A**

**NOTE:** Point number to Zone number relationship is sequential. To determine Point to Zone relationship subtract 8 from Point number to arrive at Zone number.

**ACS Selection Group B:**

Point	Type	Red LED	Yellow LED	Switch Function*
1	Input	Zone 57 Active	Zone 57 Trouble	Not Used
2	Input	Zone 58 Active	Zone 58 Trouble	Not Used
3	Input	Zone 59 Active	Zone 59 Trouble	Not Used
to		to (see note 1)	to (see note 1)	
43	Input	Zone 99 Active	Zone 99 Trouble	Not Used
44	Output	Zone F1 Active	Zone F1 Trouble	Not Used
45	Output	Zone F2 Active	Zone F2 Trouble	Not Used
to		to (see note 2)	to (see note 2)	
52	Output	Zone F9 Active	Zone F9 Trouble	Not Used
53	Release Ckt #0	Zone R0 Active	Zone R0 Trouble	Not Used
54	Release Ckt #1	Zone R1 Active	Zone R1 Trouble	Not Used
to	to	to (see note 2)	to (see note 2)	
60	Release Ckt #7	Zone R7 Active	Zone R7 Trouble	Not Used
61	NAC Output	NAC B01 Active	NAC B01 Trouble	Controls NAC B01
62	NAC Output	NAC B02 Active	NAC B02 Trouble	Controls NAC B02
63	NAC Output	NAC B03 Active	NAC B03 Trouble	Controls NAC B03
64	NAC Output	NAC B04 Active	NAC B04 Trouble	Controls NAC B04

\* Pressing the switch button when the Switch Function is "Not Used" will cause the associated LED to stop blinking. This is a local acknowledgement at the annunciator only; no message is sent to the panel.



**Table 2.15 ACS Group B**

**NOTE:**

1. Point number to Zone number relationship is sequential. To determine Point to Zone relationship, add 56 to Point number to arrive at Zone number.
2. Point number to Zone number relationship is sequential; therefore, point 48 is zone F5 and point 57 is zone R4.

**ACS Selection Group C (SLC #1, Modules 1-64):**

Point	Type	Red LED	Yellow LED	Switch Function
1	Input or Output	Module 001 Active	Module 001 Trouble	Controls Output Module
2	Input or Output	Module 002 Active	Module 002 Trouble	Controls Output Module
3	Input or Output	Module 003 Active	Module 003 Trouble	Controls Output Module
to		to (see note)	to (see note)	
64	Input or Output	Module 064 Active	Module 064 Trouble	Controls Output Module

**Table 2.16 ACS Group C**



**NOTE:** Point number to Module number relationship is sequential; therefore, point 48 is Module 048.



**ACS Selection Group D (SLC #2, Modules 1-64):**

Point	Type	Red LED	Yellow LED	Switch Function
1	Input or Output	Module 001 Active	Module 001 Trouble	Controls Output Module
2	Input or Output	Module 002 Active	Module 002 Trouble	Controls Output Module
3	Input or Output	Module 003 Active	Module 003 Trouble	Controls Output Module
to		to (see note)	to (see note)	
64	Input or Output	Module 064 Active	Module 064 Trouble	Controls Output Module

**Table 2.17 ACS Group D**

**NOTE:** Point number to Module number relationship is sequential; therefore, point 48 is Module 048.

**ACS Selection Group E (SLC #1, Modules 65-128):**

Point	Type	Red LED	Yellow LED	Switch Function
1	Input or Output	Module 065 Active	Module 065 Trouble	Controls Output Module
2	Input or Output	Module 066 Active	Module 066 Trouble	Controls Output Module
3	Input or Output	Module 067 Active	Module 067 Trouble	Controls Output Module
to		to (see note)	to (see note)	
64	Input or Output	Module 128 Active	Module 128 Trouble	Controls Output Module

**Table 2.18 ACS Group E**

**NOTE:** Point number to Module number relationship is sequential. To determine Point to Module relationship add 64 to Point number to arrive at Module number.

**ACS Selection Group F (SLC #2, Modules 65-128):**

Point	Type	Red LED	Yellow LED	Switch Function
1	Input or Output	Module 065 Active	Module 065 Trouble	Controls Output Module
2	Input or Output	Module 066 Active	Module 066 Trouble	Controls Output Module
3	Input or Output	Module 067 Active	Module 067 Trouble	Controls Output Module
to		to (see note)	to (see note)	
64	Input or Output	Module 128 Active	Module 128 Trouble	Controls Output Module

**Table 2.19 ACS Group F**

**NOTE:** Point number to Module number relationship is sequential. To determine Point to Module relationship add 64 to Point number to arrive at Module number.

**ACS Selection Group G (SLC #1 and #2, Modules 129-159):**

Point	Type	Red LED	Yellow LED	Switch Function
1	Output	SLC 1, Module 129 Active	SLC 1, Module 129 Trouble	Controls SLC 1, Module 129
2	Output	SLC 1, Module 130 Active	SLC 1, Module 130 Trouble	Controls SLC 1, Module 130

**Table 2.20 ACS Group G (1 of 2)**

Point	Type	Red LED	Yellow LED	Switch Function
3	Output	SLC 1, Module 131 Active	SLC 1, Module 131 Trouble	Controls SLC 1, Module 131
to		to (see note 1)	to (see note 1)	
31	Output	SLC 1, Module 159 Active	SLC 1, Module 159 Trouble	Controls SLC 1, Module 159
32	Not Used			
33	Output	SLC 2, Module 129 Active	SLC 2, Module 129 Trouble	Controls SLC 2, Module 129
34	Output	SLC 2, Module 130 Active	SLC 2, Module 130 Trouble	Controls SLC 2, Module 130
35	Output	SLC 2, Module 131 Active	SLC 2, Module 131 Trouble	Controls SLC 2, Module 131
		to (see note 2)	to (see note 2)	
63	Output	SLC 2, Module 159 Active	SLC 2, Module 159 Trouble	Controls SLC 2, Module 159
64	Not Used			

**Table 2.20 ACS Group G (2 of 2)**



**NOTE:**

1. Point number to Module number relationship is sequential. To determine Point to Module relationship add 128 to Point number to arrive at Module number.
2. Point number to Module number relationship is sequential. To determine Point to Module relationship add 96 to Point number to arrive at Module number.

**ACS Selection Group H (SLC #1, Detectors 1-64):**

Point	Type	Red LED	Yellow LED	Switch Function*
1	Input	Detector 001 Alarm	Detector 001 Trouble	Not Used
2	Input	Detector 002 Alarm	Detector 002 Trouble	Not Used
3	Input	Detector 003 Alarm	Detector 003 Trouble	Not Used
to		to (see note)	to (see note)	
64	Input	Detector 064 Alarm	Detector 064 Trouble	Not Used

\* Pressing the switch button when the Switch Function is "Not Used" will cause the associated LED to stop blinking. This is a local acknowledgement at the annunciator only: no message is sent to the panel.

**Table 2.21 ACS Group H**



**NOTE:** Point number to Detector number relationship is sequential; therefore, point 48 is Detector 048.

**ACS Selection Group I (SLC #2, Detectors 1-64):**

Point	Type	Red LED	Yellow LED	Switch Function*
1	Input	Detector 001 Alarm	Detector 001 Trouble	Not Used
2	Input	Detector 002 Alarm	Detector 002 Trouble	Not Used
3	Input	Detector 003 Alarm	Detector 003 Trouble	Not Used
to		to (see note)	to (see note)	
64	Input	Detector 064 Alarm	Detector 064 Trouble	Not Used

\* Pressing the switch button when the Switch Function is "Not Used" will cause the associated LED to stop blinking. This is a local acknowledgement at the annunciator only; no message is sent to the panel.

**Table 2.22 ACS Group I**

**NOTE:** Point number to Detector number relationship is sequential; therefore, point 48 is Detector 048.

**ACS Selection Group J (SLC #1, Detectors 65-128):**

Point	Type	Red LED	Yellow LED	Switch Function*
1	Input	Detector 065 Alarm	Detector 065 Trouble	Not Used
2	Input	Detector 066 Alarm	Detector 066 Trouble	Not Used
3	Input	Detector 067 Alarm	Detector 067 Trouble	Not Used
to		to (see note)	to (see note)	
64	Input	Detector 128 Alarm	Detector 128 Trouble	Not Used

\* Pressing the switch button when the Switch Function is "Not Used" will cause the associated LED to stop blinking. This is a local acknowledgement at the annunciator only; no message is sent to the panel.

**Table 2.23 ACS Group J**

**NOTE:** Point number to Detector number relationship is sequential. To determine Point to Detector relationship add 64 to Point number to arrive at Detector number.

**ACS Selection Group K (SLC #2, Detectors 65-128):**

Point	Type	Red LED	Yellow LED	Switch Function*
1	Input	Detector 065 Alarm	Detector 065 Trouble	Not Used
2	Input	Detector 066 Alarm	Detector 066 Trouble	Not Used
3	Input	Detector 067 Alarm	Detector 067 Trouble	Not Used
to		to (see note)	to (see note)	
64	Input	Detector 128 Alarm	Detector 128 Trouble	Not Used

\* Pressing the switch button when the Switch Function is "Not Used" will cause the associated LED to stop blinking. This is a local acknowledgement at the annunciator only; no message is sent to the panel.

**Table 2.24 ACS Group K**

**NOTE:** Point number to Detector number relationship is sequential. To determine Point to Detector relationship add 64 to Point number to arrive at Detector number

### ACS Selection Group L (SLC #1, Detectors 129-159, and SLC #2, Detectors 129-159):

Point	Type	Red LED	Yellow LED	Switch Function*
1	Input	SLC 1, Detector 129 Alarm	SLC 1, Detector 129 Trouble	Not Used
2	Input	SLC 1, Detector 130 Alarm	SLC 1, Detector 130 Trouble	Not Used
3	Input	SLC 1, Detector 131 Alarm	SLC 1, Detector 131 Trouble	Not Used
to		to (see note 1)	to (see note 1)	
31	Input	SLC 1, Detector 159 Alarm	SLC 1, Detector 159 Trouble	Not Used
32	Not Used			
33	Input	SLC 2, Detector 129 Alarm	SLC 2, Detector 129 Trouble	Not Used
34	Input	SLC 2, Detector 130 Alarm	SLC 2, Detector 130 Trouble	Not Used
35	Input	SLC 2, Detector 131 Alarm	SLC 2, Detector 131 Trouble	Not Used
		to (see note 2)	to (see note 2)	
63	Input	SLC 2, Detector 159 Alarm	SLC 2, Detector 159 Trouble	Not Used
64	Not Used			

\* Pressing the switch button when the Switch Function is "Not Used" will cause the associated LED to stop blinking. This is a local acknowledgement at the annunciator only; no message is sent to the panel.

**Table 2.25 ACS Group L**



#### NOTE:

1. Point number to Detector number relationship is sequential. To determine Point to Detector relationship add 128 to Point number to arrive at Detector number.
2. Point number to Detector number relationship is sequential. To determine Point to Detector relationship add 96 to Point number to arrive at Detector number.

### ACS Selection Group M

FireVoice (NFV-25/50ZS) is single channel and can play one message. Message priority is determined by the message number: lower-numbered messages have the higher priorities (that is, Message 2 has a higher priority than Message 3). Message 0 (OFF) has the lowest priority.

To use ACS for controlling the FireVoice, install by programming Annunciator A1 as Group M through panel or VeriFire Tools programming. Refer to the FireVoice manual to properly configure the FACP.

#### ■ VeriFire Tools Programming

Annunciator programming must be performed as follows:

- Program Annunciator Address 1 as Group M. (Refer to Table 2.26 for point definitions.)
- Assign ACS points in user Map 1.
- Map the panel zones to the desired annunciator point. Refer to the FireVoice NFV-25/50ZS manual for more information, including dipswitch settings..

Annunciator Point	Type
1 - 9	Unused
10	Message 0 (No Message/Message Off)
11	Message 1
12	Message 2
13	Message 3
14	Message 4
15	Message 5
16 - 39	FFT Circuits
40	All-Call

**Table 2.26 Point Definitions for Group M**

Annunciator Point	Type
41 - 64	Speaker Circuits 1 - 24

**Table 2.26 Point Definitions for Group M**

### ■ Panel Programming

If VeriFire Tools is not used and Group M is programmed at the panel, Zone 00 (general alarm) will be mapped to A1p11 and A1p40. A general alarm will play message 1 and activate an all-call on the FireVoice. VeriFire Tools must be used for speaker circuit and message control.

### ACS Selection Group N

This group is the same as Group A ( See Table 2.14 on page 35 ), with the following exceptions:

- It should be selected only for TM-4s used for remote station communication.
- Selection Group N follows the alarm relay for annunciation (Selection Group A annunciates immediately).
- The yellow LED of annunciator point 2 is for Alarm Silence only (in Selection Group A it is for Signal Silenced).

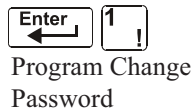
### ACS Selection Group O

This group is the same as Group A ( See Table 2.14 on page 35 ), with the following exceptions:

- It should be selected for only for TM-4s used as Fire Municipal Box Trip outputs.
- Selection Group O provides a “Master Box” trouble displayed at the panel.
- Selection Group O follows the alarm relay for annunciation (Selection Group A annunciates immediately).

The yellow LED of annunciator point 2 is for Alarm Silence only (in Selection Group A it is for Signal Silenced).

## 2.3.9 How to Check the Program for Errors (8=CHECK PRG)



When finished programming, you can use the Check option to search the program entries for possible errors. From the “Basic Program” screen, press the 8 key. The Check option searches the program for the following conditions that can cause errors:



- Output points mapped to a zone without a mapped input
- A zone with mapped input points without mapped output points (including Z00 outputs)
- Releasing zone inputs (R0-R9) with no RELEASE CKT outputs mapped to them; or RELEASE CKT outputs with no R0-R9 inputs mapped to them
- RO-R9 inputs not mapped to MAN. RELEASE.

For more information on Releasing Zones, refer to “Releasing Applications” on page 55.

If the Check option detects multiple devices that fail the check, press the PREVIOUS or NEXT key to step through the devices. If the Check option displays errors, return to Point Programming (“Modify or Delete a Point (2=point)” on page 20) and correct the errors. The figure below shows a sample display of program screen that appears after a successful program check:

```
PROGRAM CHECK OK.
RE-TEST PANEL NOW      08:34A 041508 Tue
```

## 2.4 The Network Program



Program Change  
Password



From the “Program Change Selection” screen, press the **2** key to display the “Network” screen, which displays as follows:

```
THRESHOLD CH.A:H, THRESHOLD CH.B:H,
NODE: .000, STYLE7:N, <ENTER>
```

**THRESHOLD CH.A:** - Enter H or L, for high or low threshold setting for channel A on the NCM module.

**THRESHOLD CH.B:** - Enter H or L, for high or low threshold setting for channel B on the NCM module.

**NODE:** - Enter the panel’s network node number. The valid network node number range is 1-103. The number will be entered after the decimal point; the spaces before the decimal point are for future use.

**STYLE7:** - Enter N for network style determination (either Style 4 or Style 7) through autoprogramming. Enter Y to force a Style 7 designation for network wiring.



**NOTE:** If network Style 7 wiring is determined by autoprogramming, a change in the wiring (for example, a break in the network wiring) would cause the system to reassess the network wiring style as 4. If network Style 7 wiring is forced, a break in the wiring will create a trouble message.

To select network options, follow these steps:

1. Using the arrow keys, move the blinking cursor to a selection.
2. Press the NEXT or PREVIOUS key to select **H** or **L** (Threshold Ch. A, Threshold Ch. B), a three-digit number (Node), or **Y** or **N** (Style 7).

When finished making selections, press the ESC key three times to return the control panel to normal operation.

When programming is complete, the panel must be reset to register the programming.

## 2.5 The Utility Program

There are five options available in the Utility Program. Enter the program and select an option as described below.



Program Change  
Password



From the “Program Change Selection” screen, press the **3** key to display the “Utility Program” screen as shown below:

```
REGION=0 TBL.REMIND=2 ALA.SCROLL=N
LOCAL CONTROL=0 IP-ACCESS=0 DCC-mode:Y
```

Descriptions of the five options on the Utility Program screen:

Utility Option	Description
REGION	0 = No special region setting (default) 1 = China

**Table 2.27 Utility Program Options (1 of 2)**

Utility Option	Description
TBL.REMIND TBL Reminder*	This option provides trouble resound selections to meet the requirements of NFPA 72-2002, which you can select as follows: <ul style="list-style-type: none"> <li>• Select * if you don't want a trouble reminder</li> <li>• Select <b>1</b> to sound a short trouble reminder tone every minute</li> <li>• Select <b>2</b> to resound a trouble tone every 24 hours at 11:00 AM, and to send a reminder every sixty seconds for acknowledged events.</li> <li>• Select <b>3</b> to display a detector while in the alarm verification mode and no trouble reminder</li> <li>• Select <b>4</b> for once a minute trouble reminder with alarm verification display</li> <li>• Select <b>5</b> for trouble reminder resound every 24 hours at 11:00 AM with alarm verification display, and to send a reminder every sixty seconds for acknowledged troubles</li> </ul>
ALA.SCROLL Alarm Scroll*	This option allows the programmer to select how alarms are displayed. <ul style="list-style-type: none"> <li>• Select <b>Y</b> if you want each alarm displayed for approximately two seconds, and to acknowledge all alarms with a single acknowledgement. (default)</li> <li>• Select <b>N</b> if you want only the first alarm and the alarm count displayed, and to acknowledge each alarm singly, point by point.</li> </ul>
LOCAL CONTROL	This option allows the programmer to disable local control of the ACKNOWLEDGE/SCROLL DISPLAY key, SIGNAL SILENCE key, DRILL key and SYSTEM RESET key. Select local control as follows: <ul style="list-style-type: none"> <li>• Select <b>0</b> to disable local control</li> <li>• Select <b>1</b> to enable local control (default)</li> <li>• Select <b>2</b> to enable partial local control. This setting allows control of the ACKNOWLEDGE and SYSTEM RESET keys only (required in Chicago.)</li> </ul> <p>Note that if the panel is to be controlled exclusively by a Display and Control Center (DCC), Local Control should be disabled.</p>
IP ACCESS	Note: Use of this option is subject to local AHJ approval. This option allows the programmer to choose one of three options for Wide Area Network (WAN) communication. Acceptance of commands, downloads and programming from over the WAN can be enabled, disabled or timed. Select IP ACCESS as follows: <ul style="list-style-type: none"> <li>• Select <b>0</b> to disable IP access</li> <li>• Select <b>1</b> to enable IP access</li> <li>• Select <b>2</b> to enable IP access for two hours.</li> </ul> <p>Note that enabling IP ACCESS allows downloads over a local area network (LAN) or the internet (Wide Area Network - WAN) using VeriFire Tools through a Noti•Fire•Net(NFN) Web Server (NWS), or a wide-area enabled NCS through a PC version of NFN Gateway. Always verify system operation after programming changes are made in this manner.</p>
DCC Mode	This option allows the programmer to select whether this panel will participate in DCC (Display and Control Center) functions. Select <b>Y</b> for participation, <b>N</b> for no participation.

**Table 2.27 Utility Program Options (2 of 2)**

To select utility options, follow these steps:

1. Using the arrow keys, move the blinking cursor to a selection.
2. Press the NEXT or PREVIOUS key to select
  - Local Control
  - \*, **1**, **2**, **3**, **4**, **5** (TBL Reminder)
  - **0**, **1**, or **2** (IP ACCESS)
  - DCC Mode
3. When finished making selections, press the ESC key three times to return the control panel to normal operation.



## 2.6 FlashScan Poll



Program Change  
Password



From the “Program Change Selection” screen, press the **4** key to access the “FlashScan Poll” selection screen as shown below:

F L A S H S C A N	L 1 D E T	L 1 M O D	L 2 D E T	L 2 M O D
	N	N	N	N

This menu allows the selection of CLIP (Classic Loop Interface Protocol) or FlashScan detectors and modules for each loop. Once this screen is accessed, the cursor will be positioned underneath the Loop #1 Detector selection, blinking the currently selected protocol type. The default selections are shown in the above figure. This indicates that both Loop #1 and Loop #2 detectors and modules are selected to use CLIP devices. If FlashScan devices are to be employed, change the blinking cursor by pressing the **Y** key or toggle it by using the PREVIOUS or NEXT key. After the selections have been made to the detectors and modules of both loops, press the ENTER key, at which time the panel will reset.

Most FlashScan devices can be programmed to run in either CLIP or FlashScan mode. Observe one of the following three options when using FlashScan devices:

- Option 1** Program all modules and detectors on an SLC as FlashScan.  
(In the “FlashScan Poll” screen, enter Y for DET and Y for MOD. It is possible to have up to 159 FlashScan modules and 159 FlashScan detectors on this SLC.)
- Option 2** Program all modules and detectors on an SLC as CLIP.  
(In the “FlashScan Poll” screen, enter N for DET and N for MOD. It is possible to have up to 99 CLIP modules and 99 CLIP detectors on this SLC.)



**CAUTION:**

Do not program more than 99 CLIP addresses, as this will compromise the response time of the panel to display off-normal events.

- Option 3** Program all detectors as CLIP and all modules as FlashScan on an SLC.  
(In the “FlashScan Poll” screen, enter N for DET and Y for MOD. It is possible to have up to 99 CLIP detectors and 159 FlashScan modules on this SLC.)



**CAUTION:**

Do not program modules as CLIP and detectors as FlashScan on the same SLC. This combination is not an option: Y for DET, N for MOD in the “FlashScan Poll” screen.



**NOTE:** Autoprogramming following a Clear Program command will cause the panel to determine the FlashScan capability of each loop based on whether all devices on a loop are FlashScan or not. It will set the loop settings to FlashScan if necessary.

Refer to the SLC manual for available devices.

## 2.7 Setting the Baud Rate of Serial Ports

### 2.7.1 Printer Serial Port




The default baud rate of the EIA-232 Printer connection (serial printer port) is 9600. To change baud rate to 2400 or 4800, follow these steps:

1. From the “SYSTEM NORMAL” screen, press the ENTER key to display the Program Entry screen, as shown below:

```
1=PROGRAMMING      2=READ STATUS ENTRY
(ESCAPE TO ABORT)
```

2. Press the **1** key. The control panel displays the Enter Password screen, as shown below:

```
ENTER PROG OR STAT PASSWORD, THEN ENTER.
_ (ESCAPE TO ABORT)
```

3. Enter **2400B** and press . The five asterisks that appear when you type in the baud rate will disappear when you press .
4. Press  twice to return to the “SYSTEM NORMAL” screen.
5. To switch from 2400 baud to 4800 or 9600 baud repeat steps 1, 2, and 3 entering **9600B** or **4800B**.

## 2.7.2 CRT Serial Port

The default setting for the serial EIA-232 CRT port is “disabled”. To enable the EIA-232 CRT port at 9600 baud, follow the steps below.






**NOTE:** The serial EIA-232 CRT port can only be enabled in standalone (non-networked) applications. The only baud rate supported is 9600.

1. From the SYSTEM NORMAL screen, press the ENTER key to display the Program Entry screen, as shown below:

```
1=PROGRAMMING      2=READ STATUS ENTRY
(ESCAPE TO ABORT)
```

2. Press the **1** key. The control panel displays the Enter Password screen, as shown below:

```
ENTER PROG OR STAT PASSWORD, THEN ENTER.
_ (ESCAPE TO ABORT)
```

3. Enter **CRT96** and press . The five asterisks that appear when you type in the code will disappear when you press .
4. Press  twice to return to the “SYSTEM NORMAL” screen.
5. To switch back to the default network mode (no CRT) repeat steps 1, 2, and 3 entering **NOCRT**.



# Section 3: Status Change

## 3.1 Overview

Status Change provides a second programming level - accessed by an assigned password - for changing operating parameters. (These operating parameters do not affect control program settings.) For example, the Status Change password lets you change settings such as detector sensitivity and system time and date.



---

**NOTE:** Assign the Status Change password to persons who do not have access to Level 1 programming options.

---

Status Change Options are described below.

**Option 1=DISABL** - The Disable/Enable option lets you disable programmed points for detectors, modules, zones and NACs. For details, refer to “Disable or Enable a Point” on page 48.

**Option 2=SENSITIV** - The Detector Sensitivity option lets you change the Alarm and Pre-alarm (sensitivity) level for an installed detector. For details, refer to “Changing Detector Sensitivity” on page 49.

**Option 3=CLR VER** - The Clear Verification screen lets you clear all counters for detectors selected for Alarm Verification. For details, refer to “Clearing Alarm Verification Counters” on page 50.

**Option 4=CLR HIST** - The Clear History screen lets you clear the entire History buffer from memory. For details, refer to “Clearing the History Buffer” on page 50.

**Option 5=TIME** - The Time/Date option lets you set the time and date for the system clock. For details, refer to “Setting the System Time and Date” on page 50.

**Option 6=WALK TEST** - The Walk Test option lets you test the entire fire alarm system while away from the control panel. For details, refer to “Walk Test” on page 51”.

## 3.2 How to Enter Status Change

To enter Status Change, follow these steps:

1. From the SYSTEM NORMAL” screen, press the ENTER key. The control panel displays the “Entry” screen, as shown below:

```
1=PROGRAMMING          2=READ STATUS ENTRY
```

2. From the “Entry” screen, press the 1 key. The control panel displays the “Enter Password” screen as shown below:

```
ENTER PROG OR STAT PASSWORD, THEN ENTER.
```

3. Enter your Status Change password (See “How to Enter a Password”, page page 13). The control panel displays the “Status Change Selection” screen, as shown below:

```
STATUS CHANGE PRESS: 1=DISABL 2=SENSITIV  
3=CLR VER 4=CLR HIST 5=TIME 6=WALK TEST
```

4. Select a Status Change selection: **1,2,3,4,5**, or **6**.

### 3.3 Disable or Enable a Point



**WARNING:**

**Do not rely on disable/enable software settings to lock out releasing devices. Releasing devices must be physically disconnected.**



**NOTE:** When an input or output point associated with releasing functions is disabled, a single supervisory trouble will be generated.'



Status Change Password

The Disable/Enable option lets you disable programmed points for detectors, modules, zones, and NACs. The program allows you to disable an initiating device in alarm; however, the disable will not take effect until after the panel has been reset.



1. From the “Status Change Selection” screen, press the **1** key to display the “Disable/Enable” screen.
2. Select the point type:

- for detectors
- for modules
- for NACs
- for zones

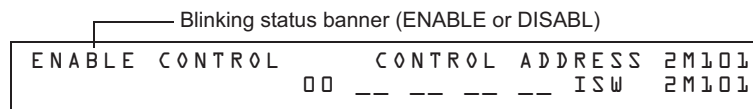
The cursor will blink the first SLC address digit in the detector, zone, module, or NAC field.



**WARNING:**

**Disabling a zone disables all input and output devices that use the zone as the first entry in the CBE list.**

3. Enter the address of the point, then press the ENTER key. A sample display follows:



When you disable a point and press the ESC key to return to the Disable/Enable screen, the control panel: a) turns on the POINT DISABLED LED; b) sounds the panel sounder; and c) changes the status banner to TROUBL for the point.

You can disable or enable a point by changing the status banner as follows:

To	Press
Change the status	Maneuver the cursor with the arrow keys until it is in the status field. Press  (Next Selection) or  (Previous Selection)

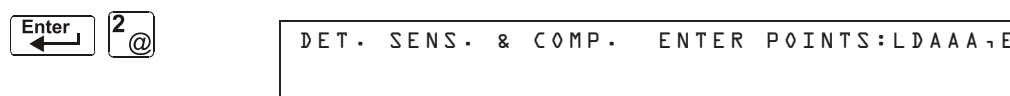
**Table 3.1 Changing the Status Banner (1 of 2)**

To	Press
Save the status	
Go to the next or previous point address	(Next Selection) or  (Previous Selection)

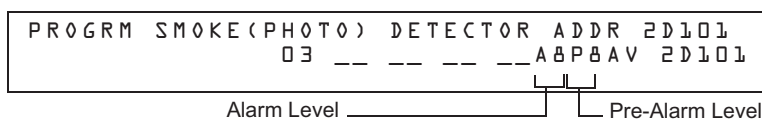
**Table 3.1 Changing the Status Banner (2 of 2)**

### 3.4 Changing Detector Sensitivity

The Detector Sensitivity option lets you change the Alarm and Pre-Alarm (sensitivity) level for an installed detector. From the “Status Change Selection” screen, press the **2** key to display the “Detector Selection” screen as shown below:



To select a detector, enter the SLC address (2D101) of an installed detector in the “LDAAA” field (shown above). The control panel displays the following screen:



Use the instructions below to set/change detector sensitivity, display additional detectors, and set Pre-alarm values.



**NOTE:** If not using Pre-Alarm, set PA=0. PA=1 is the self-optimizing mode. For details, refer to “How to Select a Pre-Alarm Level” on page 96.

To	Enter or Press
Display detector information on the screen.	The detector address, then press .
Set alarm sensitivity level.	A value (1-9) or increase or decrease values by pressing the NEXT or PREVIOUS keys:  or .
Set Pre-alarm level	A value (0-9) or increase or decrease values by pressing the NEXT or PREVIOUS keys:  or .
Save the sensitivity values.	
Display the next existing detector address.	(Next Selection)
Display the previous existing detector address.	(Previous Selection)

### 3.5 Clearing Alarm Verification Counters



Status Change  
Password



The Clear Verification screen lets you clear all counters for detectors selected for Alarm Verification. From the “Status Change Selection” screen, press the 3 key to display the “Clear Verification” screen as shown below:

```
PRESS ENTER TO CLEAR VERIFICATION COUNTS
OR ESCAPE TO ABORT
```

From the Clear Verification screen, you can do the following:

- Press the ENTER key to clear all verification counters and return to the “Status Change Selection” screen; or
- Press the ESC key to return to the “Status Change Selection” screen without clearing.

### 3.6 Clearing the History Buffer



Status Change  
Password



The Clear History screen lets you clear the entire History buffer from memory. Press the 4 key from the “Status Change Selection” screen to display the “Clear History” screen as shown below:

```
PRESS ENTER TO CLEAR HISTORY FILE
OR ESCAPE TO ABORT
```

From the Clear History screen, you can do the following:

- Press the ENTER key to clear the contents of the History buffer and return to the “Status Change Selection” screen; or
- Press the ESC key to return to the “Status Change Selection” screen without clearing.

### 3.7 Setting the System Time and Date



Status Change  
Password




The Time/Date option lets you set the time and date for the system clock. Press the 5 key from the “Status Change Selection” screen to display the “Time/Date” screen as shown below:

```
CHANGE TIME/DATE      11:40A Tue 04/15/2008
```

The first digit flashes until you change the value or press the ENTER key. To set the system time and date, follow the instructions below:

To	Do this
Change the time and date values	Enter values from the numeric keys on the keypad.
Change A (AM) or P (PM)	Press  (Next Selection) or  (Previous Selection)
Change the day	Press  (Next Selection) or  (Previous Selection)
Move to another digit	Press



To	Do this
Save the time and date and return	Press 

## 3.8 Walk Test

Walk Test allows the user to test the entire fire alarm system. There are two kinds of Walk Test - Basic and Advanced, described later in this section.

Before entering Walk Test, note the following:

- For each individual activation, the control panel sends “TEST Axx”(for alarm testing) or TEST Txx (for trouble testing) to the History buffer, installed printers and CRT-2s so results can be reviewed.
- Basic Walk Test, Silent – In order to keep the test silent, do not program any of the output modules with “W” in the Walk Test field .
- Advanced Walk Test - This test overrides a setting of “\*” (silent) in the Walk Test field. All activated outputs will sound until panel reset.
- The control panel provides a 1-hour timer for Walk Test mode. When the hour expires with no activity, the control panel automatically returns to normal operation.
- Walk Test may be exited at any time by pressing the ESC key.




---

**WARNING:**

Walk Test mode deactivates fire protection. Always observe the following:

---

1. Prior to Walk Test, secure all protected buildings, and notify the building owner/operator, fire department, and other pertinent personnel that testing is in progress.
2. Immediately after Walk Test is completed, notify the same people that testing is complete and is restored to normal operation.




---

**WARNING:**

**Physically disconnect all releasing devices before starting Walk Test. It is not sufficient to disable in any other manner.**

---




---

**NOTE:** Walk Test will not start if any devices are active (i.e., fire alarms, security, supervisories or pre-alarms.) To perform a walk test while a device is active, disable the device and press the System Reset button.

---



For information on programming Walk Test field selections, refer to “Modify an Addressable Control Module Point” on page 23 or “Modify NAC Points” on page 25.

### 3.8.1 Basic Walk Test

When the tester activates an input during Basic Walk Test , all silenceable outputs mapped by CBE to that input will activate. The activations are tracking; once the activation stimulus is removed, the input will deactivate. Basic Walk Test may be audible or silent, depending on the Walk Test setting of participating outputs. Program the Walk Test field for control modules and NACs as follows:



For	Program Silenceable Outputs with	Silenceable Outputs will
an audible Basic Walk Test	<b>W</b>	sound for approximately 4 seconds during Walk Test
a silent Basic Walk Test	<b>*</b>	not sound during Walk Test
a trouble Basic Walk Test	<b>W</b>	sound for approximately 8 seconds when put into trouble

Enter Basic Walk Test in the following manner:



  From the “Status Change Selection” screen, press the **6** key. The control panel displays the “Walk Test” screen as shown below:

Status Change Password

WALK TEST ESCAPE TO ABORT	PRESS ENTER TO START
------------------------------	----------------------

Operate the control panel in Walk Test as follows

To	Press
Put the control panel into Walk Test mode	
Stop a Walk Test and return to the “Status Change Selection” screen	

Basic Walk Test directs the control panel to do the following:

- Activate silenceable outputs associated by programming with each new alarm. (The panel does not activate non-silenceable outputs.)
- Save and store each test in the History buffer
- Send a TEST Axx status banner for each alarm, and a TEST TXX banner for each trouble, to the printer (xx equals the number of tests for a detector or input device with this address)
- Turn on the System Trouble LED
- Turn on the System Trouble relay
- Disable activation of the System Alarm relay

## 3.8.2 Advanced Walk Test

During Advanced Walk Test, when the tester activates an input, all CBE mapped to that input will activate with the exception of releasing functions. Each input activation is latching; that is, it will not deactivate until the system is reset. Advanced Walk Test will sound all activated outputs, overriding a setting of “\*” (silent) in the Walk Test field.






**NOTE:** Some detectors, laser detectors for example, can be difficult to place in alarm using a magnet. Advanced Walk Test facilitates magnet testing of these detectors.

Enter Advanced Walk Test as follows:

Enter LTEST at the password screen. Asterisks will display where LTEST has been typed. Pressing ENTER displays the following screen.


LTEST

 	<p>TR OUBL IN SYST E M    A D V W A L K T E S T P R O C E S S I N G   D I S A B L E D   1 0 : 0 7 a   0 4 1 5 0 8   M O N</p>
---	---





**NOTE:** The control panel can not be put into Walk Test from an alarm condition.

To	Press
Stop an Advanced Walk Test and return to the "Status Change Selection" screen	

Advanced Walk Test directs the control panel to do the same as it does for Basic Walk Test (see "3.8.1, "Basic Walk Test"" above) with the following exceptions:

- alarm and trouble messages are sent to the printer, not test messages. (These Walk Test messages can be distinguished from others at the printer because they begin with the trouble message generated when Walk Test is entered, and end with the cleared trouble when Walk Test is exited.)
- all CBE mapped to the test input is activated except releasing functions.

## 3.8.3 Walk Test Activation Indications

Walk Test Activation Indications

FlashScan poll mode - Once the test is started:

- each intelligent addressable input device will blink its address in red, and each intelligent addressable output device will blink its address in green. Pattern examples are given below.

<u>Address</u>	<u>Blink Pattern</u>
8	8 blinks, long stop, 8 blinks, long stop,....
37	3 blinks, stop, 7 blinks, long stop, 3 blinks, stop, 7 blinks, long stop,....
70	7 blinks, stop, 10 blinks, long stop, 7 blinks, stop,.....
107	10 blinks, stop, 7 blinks, long stop, 10 blinks, stop,.....
152	15 blinks, stop, 2 blinks, long stop, 15 blinks, stop, 2 blinks, long stop....

- an input device activated in Basic Walk Test latches on steady green for the duration of the test.
- an output device activated in Basic Walk Test will remain active and the LED will glow steady green for:
  - approximately 4 seconds for alarms
  - approximately 8 seconds for troubles.
- an output device activated in Advanced Walk Test will remain active and the LED will glow steady green until the reset key is pressed.

CLIP mode - Once the test is started:

- intelligent addressable input and output devices continue to blink red as usual until activated.
- an input device activated in Basic Walk Test latches on steady red during activation. If the device is put in trouble (for instance, the detector head is removed, then replaced), the LED will be latched on for the duration of the test.
- an output device activated during Basic Walk Test will remain active and the LED will glow steady green (if a FlashScan module) or steady red (if a CLIP module) for:
  - approximately 4 seconds for alarms
  - approximately 8 seconds for troubles.
- an output device activated in Advanced Walk Test will remain active and the LED will glow steady green (if a FlashScan module) or steady red (if a CLIP module) until the reset key is pressed.

### 3.8.4 Viewing Walk Test Results

When finished with a Walk Test, view the History buffer, installed printers and CRT-2s to check the results of the Walk Test. View the History buffer by using the Read Status function. From the SYSTEM NORMAL screen, press the ENTER key, press the **2** key two times, then press the ENTER key to view the History buffer. For further instructions on using the Read Status function, refer to the *NF2S-640 Operations Manual*.

# Appendix 4: Releasing Applications



**WARNING:**

When used for CO<sub>2</sub> releasing applications, observe proper precautions as stated in NFPA 12. Do not enter the protected space unless physical lockout and other safety procedures are fully completed.

Do not use software disable functions in the panel as lockout.

Do not enable the BACKUP option switch for any of the four Notification Appliance Circuits (NACs) if they are used for releasing functions.

## 4.1 Overview

### 4.1.1 Description of Releasing Zones

The control panel includes ten Releasing Zones (R0-R9) that can be used to control up to ten releasing operations. Each zone operates independently, and is fully programmable..



**NOTE:** Releasing Zones R0-R9 appear in the CBE list of devices as ZR0-ZR9. For example, if you list R5 for a detector, one of the five zones in the CBE list of the detector will display as ZR05.

From the “Special Function Change” screen (refer to “Program Special Zones (6=spl funct)” on page 28), select a Releasing Zone (R0-R9) to display the “Releasing Function” screen:

```
PRG RELEASE FUNCTION RELEASE CONTROL  
DELAY=30 ABORT=ULI CROSS=N SOK=0000 R05
```

Each Releasing Zone includes four releasing functions, outlined below:

Function	Lets You
Delay	Program a 01 to 60-second Delay Timer (or 00, no delay). The Delay Timer equals the time that must elapse between activating an initiating device and activating the releasing zones mapped to the active initiating device. Refer to “Programming a Delay Timer” on page 56.
Abort	Select a 3-letter Abort switch Type Code (ULI, IRI, NYC, or AHJ) that adds a delay time to a Releasing Zone, or prevents a release of a Releasing Zone. Refer to “Abort Switches” on page 57.
Cross	Select one of three Cross Zone types or “N” (not used). A Cross Zone requires tripping two or more devices to activate the outputs mapped to one of the Releasing Zones. Refer to “Using Cross Zones” on page 65.
Soak	Select a Soak Timer (0001-9999 seconds) or “0000” (not used). Refer to “Programming a Soak Timer” on page 67.

**Table 4.1 Releasing Zone Functions**

## 4.1.2 NFPA Releasing Applications

This control panel can be used for agent release or preaction/deluge control applications. In a properly configured system with compatible, listed actuating and initiating devices, this control panel complies with the following NFPA standards for installation in accordance with the acceptable standard:

Standard	Covers
NFPA 12	CO <sub>2</sub> Extinguishing Systems
NFPA 12A	Halon 1301 Extinguishing Systems
NFPA 13	Sprinkler Systems, Installation of
NFPA 15	Water Spray Fixed Systems
NFPA 16	Foam-water Deluge and Foam-water Spray Systems
NFPA 17	Dry Chemical Extinguishing Systems
NFPA 17A	Wet Chemical Extinguishing Systems
NFPA 2001	Clean Agent Fire Extinguishing Systems

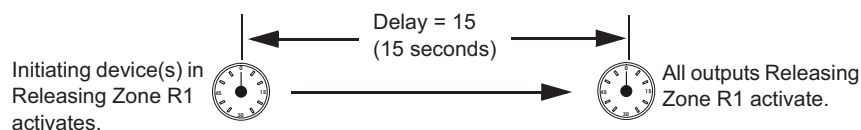
**Table 4.2 NFPA Standards for Releasing Applications**

## 4.2 How to Program a Releasing Zone

This section provides details for programming the releasing functions: Delay Timer, Abort Switch, Cross Zone, and Soak Timer.

### 4.2.1 Programming a Delay Timer

Use a Delay Timer to specify the elapsed time between alarm activation of an initiating device and activation of all output devices programmed as release circuits and mapped to that initiating device. You can set the Delay Timer from 01 to 60 seconds, or to 00 for no delay. The figure below shows graphical representation of a 15-second timer:



**Figure 4.1 Example of 15-Second Delay Timer**

To Program	Do this
Delay Timer	Enter a value (00-60) from the numeric keys on the keyboard.

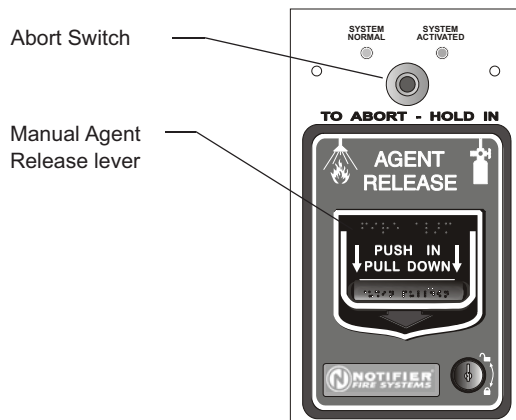
Press  at this point to save the Delay Timer value if no other fields on the screen are changing. To change another field on the screen, move the cursor into position by pressing the arrow keys.

## 4.2.2 Abort Switches

### Definition of Abort Switches

The control panel provides for four (4) types of Abort Switches (ULI, IRI, NYC, and AHJ) that you can use, that will affect the operation of a Delay Timer mapped to the same Releasing Zone. For example, an Abort Switch selected for Releasing Zone R05 only affects the Delay Timer selected for R05. Other requirements for using an Abort Switch include the following:

- Connecting a monitor module to a UL-listed abort station, such as the NBG-12LRA shown below.
- Program the monitor module with the Type Code ABORT SWITCH. (Refer to “Modify an Addressable Monitor Module Point” on page 22.)
- Abort switch shall not be used with a preaction system or a CO<sub>2</sub> system.



NBG-12LRA station with Abort Switch

NBG12LRAface.wmf

**Figure 4.2 UL-listed Abort Station**

This section contains information for programming each type of Abort Switch for a Releasing Zone.

### How an Abort Switch Works

The figure below contains an example for configuring an Abort Switch and shows the requirements for using an Abort Switch for Releasing Zone R05, which are:

- A monitor module is wired to an abort station
- The monitor module is programmed with the Type Code, ABORT SWITCH
- All initiating devices and outputs are mapped to a common Releasing Zone (R05 shown)
- Releasing Zone R05 is programmed with the releasing functions: Delay, Abort, Cross, and Soak



When an initiating device activates, you must press and hold the Abort Switch or the control panel will send the command to dump releasing agents when the Delay time (15 seconds shown) expires. The Abort selection (ULI, IRI, NYC, or AHJ) determines the function of the Abort Switch.

```

PRG RELEASE FUNCT  RELEASE CONTROL
DELAY=15  ABORT=ULI  CROSS=N  SOK=0000  R05
    
```

Releasing Zone R05 sample programming selections

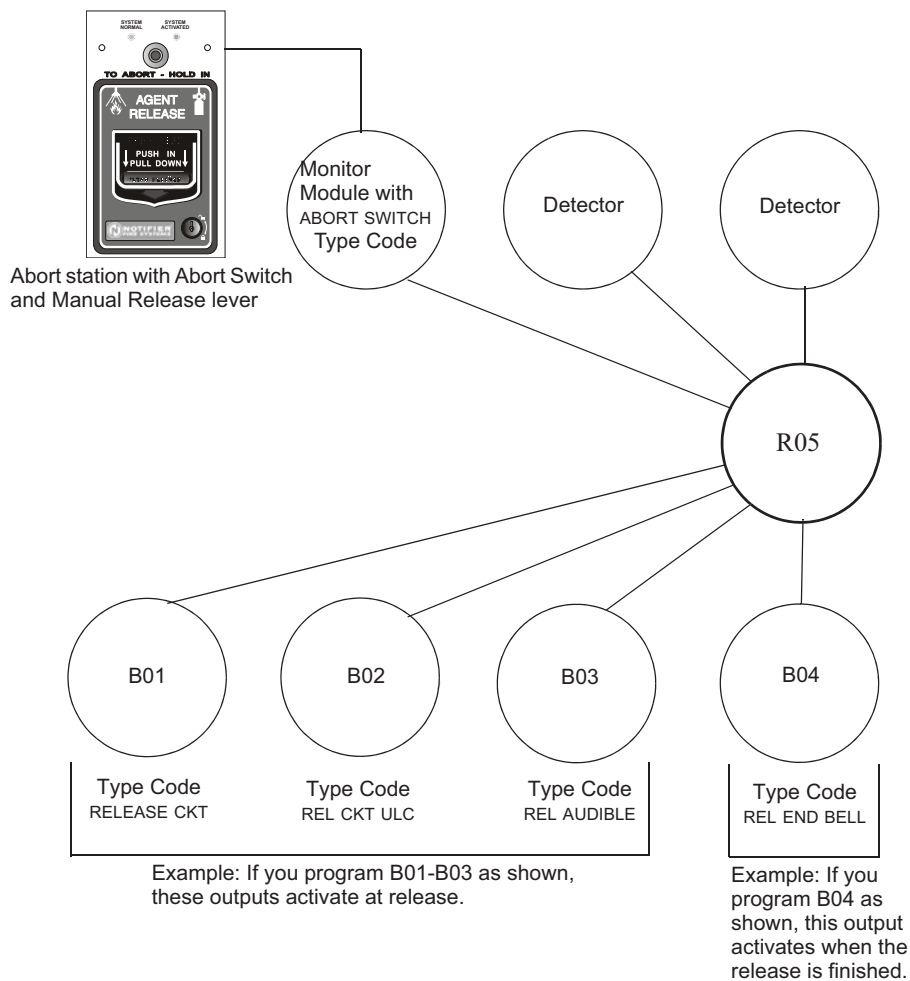


Figure 4.3 Example of a Basic Configuration for an Abort Switch

### Programming a ULI Abort Switch

The following contains information needed to program a ULI Abort Switch.

#### ■ Description

Requires a standard UL-type delay timer that complies with UL Standard 864.

#### ■ How to Program

1. Program the monitor module connected to the abort station with the Type Code ABORT SWITCH as detailed in “Modify an Addressable Monitor Module Point” on page 22.
2. Select a time for the Releasing Zone Delay Timer (refer to “Programming a Delay Timer” on page 56).

To Program	Do this
ULI Abort Switch	Type ULI in the ABORT= field, or press the NEXT or PREVIOUS keys: <input type="button" value="+"/> or <input type="button" value="-"/> until ULI appears in the field.

3. Press  at this point to save the Abort Switch value if no other fields on the screen are changing. To change another field on the screen, move the cursor into position by pressing the arrow keys on the keypad.

#### ■ How It Works

When an alarm initiates in the programmed Releasing Zone, you can press and hold the Abort Switch while the Delay Timer continues to count down. (If the delay timer has expired, the abort switch has no effect.) When you release the Abort Switch, a 10-second ULI timer counts down. At the end of the 10-second ULI timer, the control panel activates the Releasing Zone outputs.

#### ■ Example

A ULI Abort Switch and a Delay Timer programmed to Releasing Zone R05:

```
PRG RELEASE FUNCT  RELEASE CONTROL
DELAY=15  ABORT=ULI  CROSS=N  SOK=0000  R05
```

Program selections for Releasing Zone R05

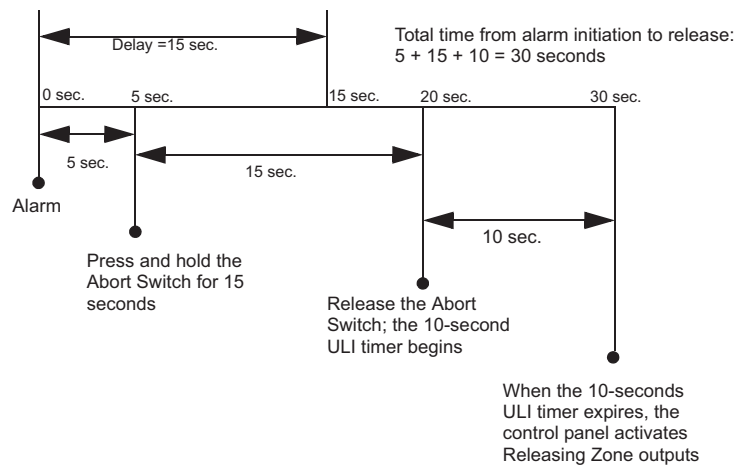


Figure 4.4 ULI Abort Switch Example

### Programming an IRI Abort Switch

The following contains information needed to program an IRI Abort Switch.

#### ■ Description

A standard UL-type delay timer (complies with UL Standard 864) that operates like ULI, but with additional functions for Cross Zones.

#### ■ How to Program

1. Program the monitor module connected to the abort station with Type Code ABORT SWITCH as detailed in “Modify an Addressable Monitor Module Point” on page 22.
2. Select a time for the Releasing Zone Delay Timer (refer to “Programming a Delay Timer” on page 56.)

To Program	Do this
IRI Abort Switch	Type IRI in the ABORT= field, or press the next or previous keys, <input type="button" value="+"/> or <input type="button" value="-"/> , until IRI appears in the field.

3. Press  at this point to save the Abort Switch value if no other fields on the screen are changing. To change another field on the screen, move the cursor into position by pressing the arrow keys on the keypad.

#### ■ How it Works

When the first alarm occurs in a releasing zone programmed with a cross-zone code, pressing the abort switch will prevent activation of the releasing zone should a second alarm occur while the switch is held. When the abort switch is released, if a second alarm has occurred while the switch was held, the ten-second IRI timer activates immediately, and the control panel activates the releasing zone outputs at the end of the IRI timer countdown. When the abort switch is released and a second alarm has not occurred while the switch was held, the panel waits for the cross-zone conditions to be met before activating the releasing zone.



#### WARNING:

The IRI abort switch will only work if it is pushed before the second alarm occurs. If it is pushed after the second alarm, the releasing zone will already have been activated, and the switch will have no effect.

#### ■ Example

An IRI Abort Switch and a Delay Timer programmed to Releasing Zone R05:

```

PRG RELEASE FUNCT  RELEASE CONTROL
DELAY=15 ABORT=IRI  CROSS=Z  SOK=0000  R05
    
```

Program selections for Releasing Zone R05

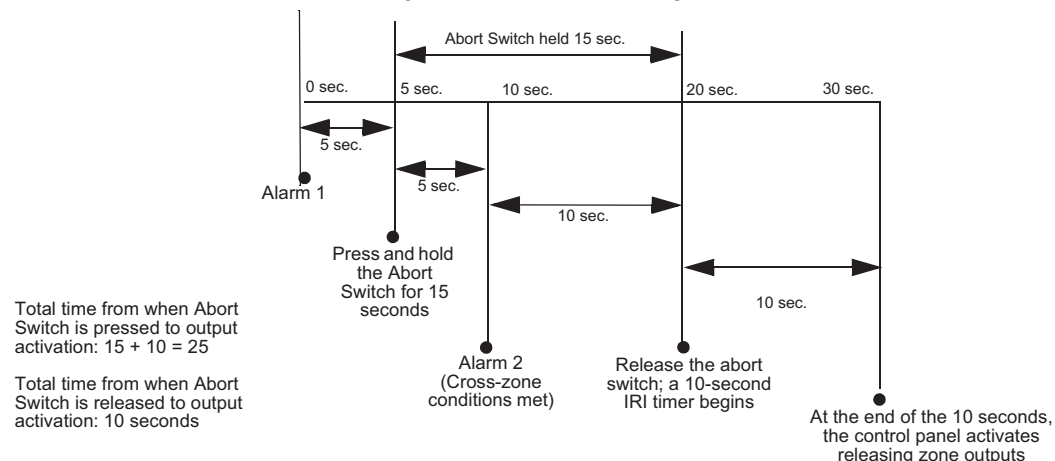


Figure 4.5 IRI Abort Switch Example

## Programming a NYC Abort Switch

The following contains information needed to program an NYC Abort Switch.

### ■ Description

A standard NYC delay timer that adds 90 seconds to the programmed Delay Timer.



**NOTE:** NYC timers do not comply with UL Standard 864.

### ■ How to Program

1. Program the monitor module connected to the abort station with the Type Code ABORT SWITCH as detailed in “Modify an Addressable Monitor Module Point” on page 22.
2. Select a time for the Releasing Zone Delay Timer (refer to “Programming a Delay Timer” on page 56.)

To Program	Do this
NYC Abort Switch	Type NYC in the ABORT= field, or press the next or previous keys, <input type="button" value="+"/> or <input type="button" value="-"/> , until NYC appears in the field.

3. Press  at this point to save the Abort Switch value if no other fields on the screen are changing. To change another field on the screen, move the cursor into position by pressing the arrow keys on the keypad.

### ■ How It Works

When an alarm initiates in the programmed Releasing Zone, pressing and holding the Abort switch stops the Delay Timer countdown. The Delay Timer restarts at the beginning of its countdown when the Abort switch is released. When the Delay Timer expires, the 90-second NYC timer starts counting down. When both timers expire, the control panel activates Releasing Zone outputs.



**NOTE:** 120 seconds is the maximum delay after the Abort switch is released. If the Delay Timer time plus the NYC delay time of 90 seconds exceeds 120 seconds, Releasing Zone outputs will still be activated at 120 seconds after the Abort switch is released.

### ■ Example 1 - Delay Time Does Not Exceed 120 Seconds

Select a Delay Timer value for R05 of 15 seconds. The Releasing Zone activates and the 15-second Delay Timer starts. Ten seconds into the Delay Timer countdown, press and hold the Abort Switch for 30 seconds, then release the Abort Switch. The control panel restarts the Delay Timer at 15 seconds and adds the NYC delay of 90 seconds. The delay timers will both expire at 105 seconds,

and Releasing Zone outputs will begin releasing at that time. Following is an example of a NYC Abort Switch and a Delay Timer programmed to Releasing Zone R05:

```
PRG RELEASE FUNCTION RELEASE CONTROL
DELAY=15 ABORT=NYC CROSS=N SOK=0000 R05
```

Program selections for Releasing Zone R05

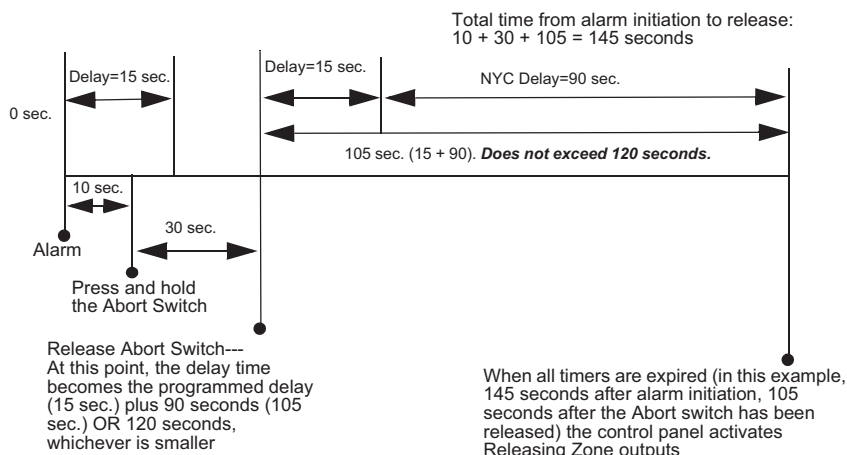


Figure 4.6 NYC Abort Switch Example 1

■ Example 2 - Delay Time Exceeds 120 Seconds

Select a Delay Timer value for R05 of 60 seconds. The Releasing Zone activates and the 60-second Delay Timer starts. Ten seconds into the Delay Timer countdown, press and hold the Abort Switch for 30 seconds, then release the Abort Switch. The control panel restarts the Delay Timer at 60 seconds and adds the NYC delay of 90 seconds. The delay timers will both expire at 150 seconds: however, this time exceeds the maximum of 120 seconds, so the Releasing Zone outputs will begin releasing at 120 seconds, not at 150. Following is an example of a NYC Abort Switch and a Delay Timer programmed to Releasing Zone R05:

```
PRG RELEASE FUNCTION RELEASE CONTROL
DELAY=60 ABORT=NYC CROSS=N SOK=0000 R05
```

Program selections for Releasing Zone R05

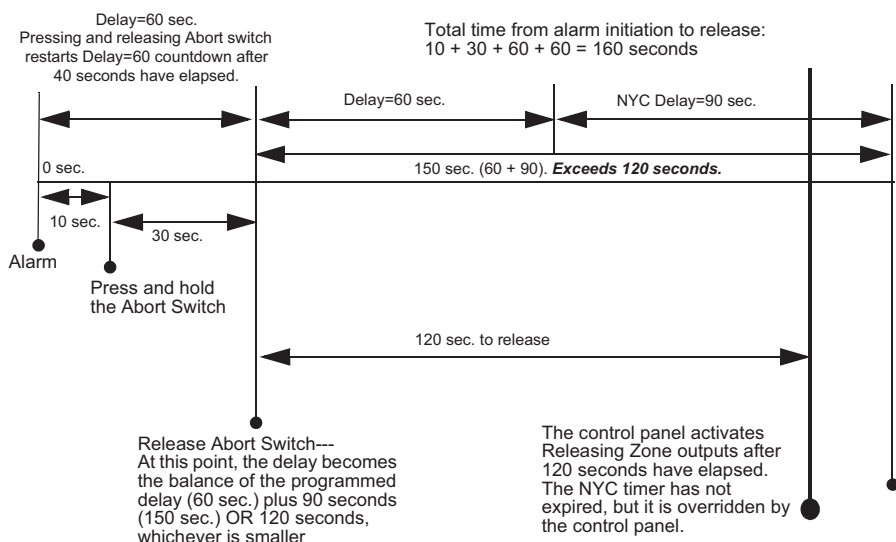


Figure 4.7 NYC Abort Switch Example 2

## Programming an AHJ Abort Switch

The following contains information needed to program an AHJ Abort Switch:

### ■ Description

An AHJ (Authority Having Jurisdiction) delay timer that restores the programmed Delay Timer.



**NOTE:** An AHJ timer does not comply with UL Standard 864.

### ■ How to Program

1. Program the monitor module connected to the abort station with the Type Code ABORT SWITCH as detailed in “Modify an Addressable Monitor Module Point” on page 22.
2. Select a time for the Releasing Zone Delay Timer (refer to “Programming a Delay Timer” on page 56).

To Program	Do this
AHJ Abort Switch	Type AHJ in the ABORT= field, or press the NEXT or PREVIOUS keys, <input type="button" value="+"/> or <input type="button" value="-"/> , until AHJ appears in the field.

3. Press  at this point to save the Abort Switch value if no other fields on the screen are changing. To change another field on the screen, move the cursor into position by pressing the arrow keys on the keypad.

### ■ How It Works

When an alarm initiates, the programmed Delay Timer starts. Press and hold the Abort switch and the control panel suspends the Delay Timer. When you release the Abort Switch, the control panel restores the value of the programmed Delay Timer and the Delay Timer counts down. When the Delay Timer expires, the control panel activates Releasing Zone outputs.

■ Example

An AHJ Abort Switch and a Delay Timer programmed to Releasing Zone R05:

```

PRG RELEASE FUNCTION RELEASE CONTROL
DELAY=60 ABORT=AHJ CROSS=N SOK=0000 R05
    
```

Program selections for Releasing Zone R05

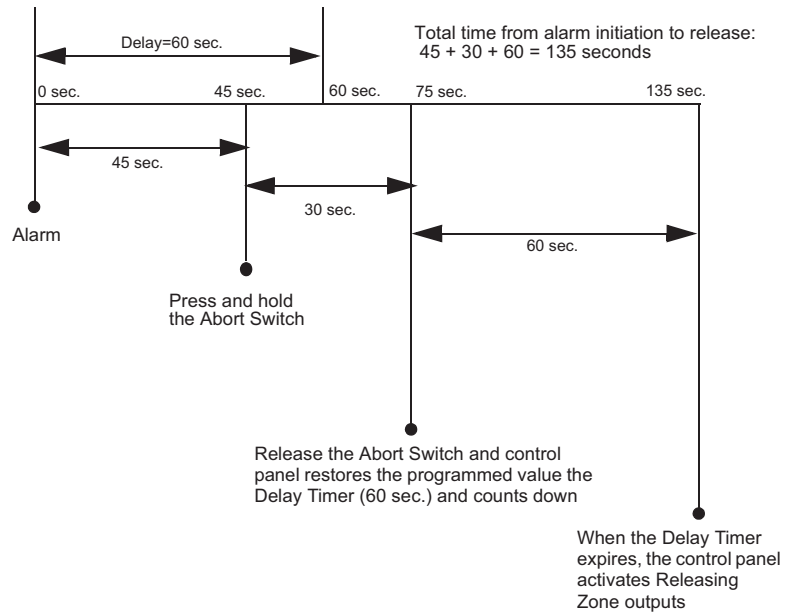


Figure 4.8 AHJ Abort Switch Example



## 4.2.3 Using Cross Zones

### Purpose of Cross Zones

Using Cross Zones lets you program the control panel to activate a Releasing Zone and any output mapped to the Releasing Zone only after a predetermined sequence of events occurs. (If not using Cross Zones, set CROSS= N.)



**NOTE:** Only the first Software Zone (Z01-Z99) listed in the zone map is used to determine Cross=Z.

A summary of the types of Cross Zones and the conditions for activating a Releasing Zone:

Type	Activates when
Y	Two or more detectors are alarmed that are mapped to one of the ten Releasing Zones (R0-R9).
Z	Two or more detectors are alarmed that are mapped to two different software zones and mapped to one of the ten Releasing Zones (R0-R9).
H	At least one smoke detector mapped to one of the ten Releasing Zones (R0-R9) is alarmed and at least one heat detector mapped to the same Releasing Zone (R0-R9) is alarmed.



**NOTE:** When in alarm, Special Zones R0-R9 appear in the CBE list as ZR00-ZR09. For example, R5 appears in the CBE list as ZR05.

### How Cross Zones Work

Below is an illustrated example of how Cross Zones work, using five Cross Zone selections (four detectors and a NAC mapped to Releasing Zone R1):

```
PROGRAM SMOKE(PHOTO) DETECTOR ADDR 2D101
      01 R1 -- -- --ABPB** 2D101
```

CBE list = 01 R1

```
PROGRAM SMOKE(PHOTO) DETECTOR ADDR 2D102
      01 R1 -- -- --ABPB** 2D102
```

CBE list = 01 R1

```
PROGRAM SMOKE(PHOTO) DETECTOR ADDR 2D103
      02 R1 -- -- --ABPB** 2D103
```

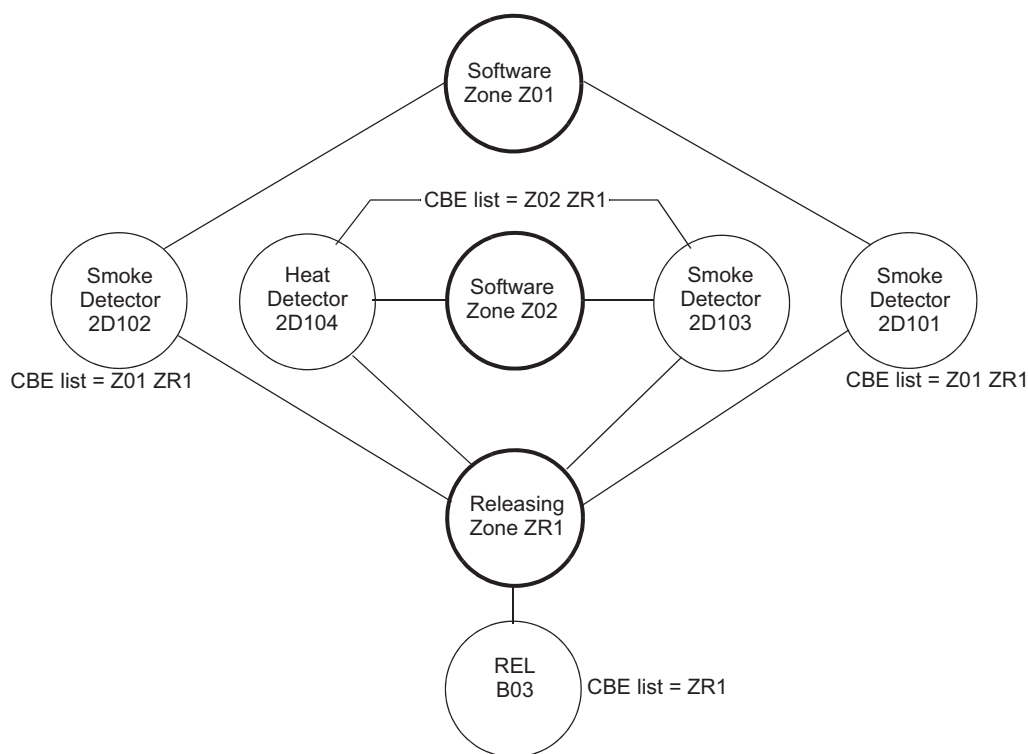
CBE list = 02 R1

```
PROGRAM HEAT(ANALOG) DETECTOR ADDR 2D104
      02 R1 -- -- -- ** 2D104
```

CBE list = 02 R1

```
PROGRAM RELEASE CKT FRONT HALLWAY NO. 3
      R1 -- -- -- I** B03
```

CBE list = R1



**Figure 4.9 Illustrated Example of Cross Zone Programming**

A listing of each Cross Zone option and the conditions required to activate the Releasing Zone, according to the example shown above.

Cross Zone Selection (Cross=)	Condition(s) Required to Activate the Releasing zone
Cross=N	An alarm from any detector activates the releasing circuit.
Cross=Y	An alarm from any two detectors activates the releasing circuit.
Cross=Z	An alarm from two detectors mapped to different Software Zones, but mapped to the same Releasing Zone. • An alarm from 2D101 and 2D103 • An alarm from 2D102 and 2D104 • An alarm from 2D101 and 2D104 • An alarm from 2D102 and 2D103 The two detectors listed in each set above are each mapped to different zones, but both list ZR1 in their CBE.
Cross=H	Activation of heat detector 2D104 and one smoke detector (2D101, 2D102, or 2D103).

Select a time for the Releasing Zone Delay Timer (refer to “Programming a Delay Timer” on page 56.)


To Program	Do this
Cross Zones	Type N, Y, Z, or H in the CROSS= field, or press the NEXT or PREVIOUS keys, <input type="button" value="+"/> or <input type="button" value="-"/> , until N, Y, Z or H appears in the that field.

Press  at this point to save the Cross Zone value if no other fields on the screen are changing. To change another field on the screen, move the cursor into position by pressing the arrow keys on the keypad.

## 4.2.4 Programming a Soak Timer

The Soak Timer specifies the length of time (0001 to 9999 seconds, or 0000 for not used) to dump releasing agents when a Releasing Zone activates. When the Soak Timer expires, the control panel automatically shuts off the releasing solenoids for the active Releasing Zone. To program a Soak Timer for a Releasing Zone, follow these instructions:

To Program	Do this
Soak Timer	Type a seconds value of 0000 (no soak timer) to 9999 from the numeric keys on the keypad in the SOK= field.

Press  at this point to save the Soak Timer value if no other fields on the screen are changing. To change another field on the screen, move the cursor into position by pressing the arrow keys on the keypad.

A Soak Timer value of 600 seconds is shown below:

```
PRG RELEASE FUNCTION RELEASE CONTROL
DELAY=00 ABORT=ULI CROSS=N SOK=0600 R00
```

## 4.2.5 Using Type Codes for Releasing Zones

The control panel provides a set of Type Codes designed for releasing applications for inputs and outputs. This section details how to program each of these Type Codes.

Type Codes designed for Releasing Zone **inputs** (monitor modules).

Type Code	What the Type Code does	Refer to
ABORT SWITCH (tracking)	Provides an abort function through a monitor module (connected to a UL-listed abort station) for a Releasing Zone.	"abort switch Type Code" on page 69
MAN. RELEASE (latching)	Provides a manual release through a monitor module (connected to a UL-listed pull station) for a Releasing Zone.	"man. release Type Code" on page 70
MAN REL DELAY (latching)	Provides a manual release with a 30-second delay (dependent on the FACP Delay setting) through a monitor module (connected to a UL-listed pull station) for a Releasing Zone.	"manrel delay Type Code" on page 71
SECOND SHOT (latching)	Provides a second manual release through a monitor module (connected to a UL-listed pull station) for a Releasing Zone.	"second shot Type Code" on page 73

Type Codes designed for Releasing Zone **outputs** (control modules and panel NACs).

Type Code	What the Type Code does	Refer to
REL END BELL	Activates a NAC audio or visual device when releasing circuits shut off.	"release end bell" on page 75
REL CKT ULC	Directs outputs to perform a release function as required by ULC.	"rel ckt ulc Type Code" on page 77
RELEASE CKT	Directs outputs to perform a releasing function.	"release ckt Type Code" on page 79
RELEA. FORM C	Directs relay outputs to perform a releasing function.	"Relea. Form-C Type Code" on page 81
REL AUDIBLE	Activates audio or visual devices steady when releasing starts.	"rel audible Type Code" on page 83
INSTANT RELE	Activates non-releasing output (panel NAC or control modules) with no delay time.	"instant rele Type Code" on page 85
REL CODE BELL	Activates audio or visual devices to pulse at 20 ppm (initial zone of a Cross Zone) or 120 ppm (Cross Zone satisfied). Steady on release.	"REL CODE BELL Type Code" on page 86

### ABORT SWITCH Type Code

The following contains information needed to program an Abort Switch for a monitor module

#### ■ Description

A monitor module, connected to a UL-listed abort station (such as the Notifier NBG-12LRA), that you use as an abort switch for a Releasing Zone. You can program multiple monitor modules with the ABORT SWITCH Type Code that work like multiple conventional abort switches on a conventional zone.

#### ■ Programming

1. Select a monitor module to use as an Abort Switch (refer to “Modify or Delete a Point (2=point)” on page 20).
2. Select the ABORT SWITCH Type Code.



3. Select the Releasing Zone (R0-R9) for your releasing application.
4. Press the enter key to save, then press the esc key until you return to the Program Change screen.
5. Select the type of Abort Switch for your releasing application (refer to “Abort Switches” on page 57).

#### ■ Example

A programming example of a monitor module programmed as an Abort Switch for Releasing Zone R5.

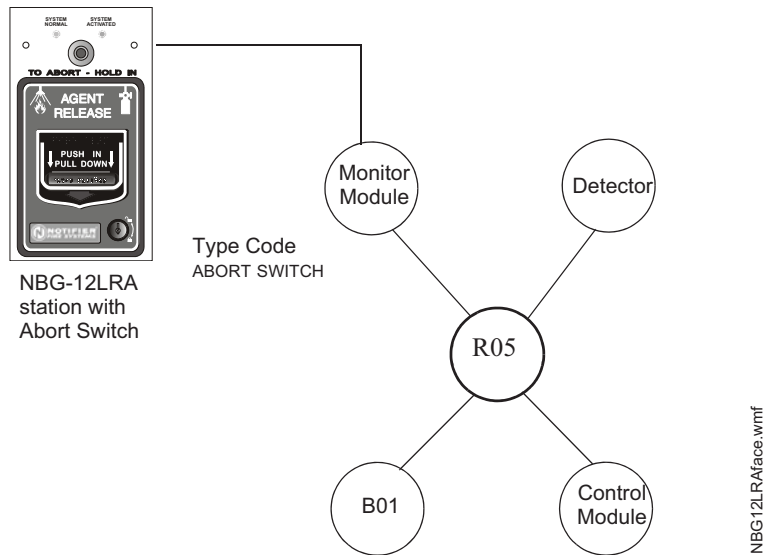


Figure 4.10 Monitor Module Configured as an Abort Switch

### MAN. RELEASE Type Code

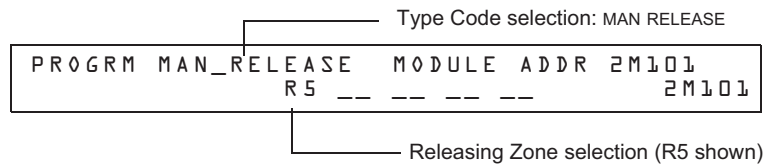
The following contains information needed to program a Manual Release switch for a monitor module.

#### ■ Description

A monitor module—connected to a UL-listed manual station (such as the Notifier NBG-12LRA)—used to manually release agents. A Manual Release switch overrides all timers, such as a Delay Timer or a Soak Timer. You can install multiple monitor modules with a MAN. RELEASE Type Code that work like multiple conventional manual release switches on a conventional zone.

#### ■ Programming

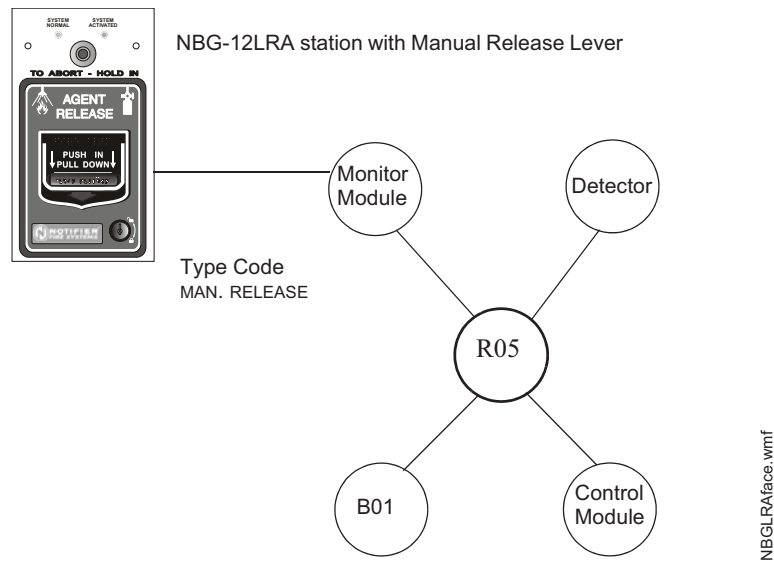
1. Select a monitor module (refer to “Modify or Delete a Point (2=point)” on page 20) to use for the manual release function.
2. Select the MAN. RELEASE Type Code.



3. Select the Releasing Zone (R0-R9) for your releasing application.
4. Press the ENTER key to save, then press the ESC key until you return to the Program Change screen.

#### ■ Example

A programming example of a monitor module programmed as an manual release switch for Releasing Zone R5.



**Figure 4.11 Monitor Module Configured as a Manual Release Switch**

## MANREL DELAY Type Code

The following contains information needed to program a Manual Release Delay switch for a monitor module using the MANREL DELAY Type Code.

### ■ Description

A monitor module—connected to a UL-listed manual station (such as the Notifier NBG-12LRA)—used to initiate a manual release with 30-second delay time.

A Manual Release Delay switch overrides the FACP programmed Delay Timer in certain circumstances, but not the soak timer.

#### *Override Circumstances:*

When the Manual Release Delay Switch activates, the control panel replaces the Delay Time with 30 seconds if the Delay Timer

- is set to more than 30 seconds
- is running, *and*
- has not counted down below 30 seconds.



**NOTE:** When the Delay Timer is set to less than 30 seconds, activation of the Manual Release Delay Switch will invoke the FACP programmed Delay Time if the Delay Timer is not running, or the FACP programmed Delay Timer countdown time if it is running. Refer to the examples 1 through 5 later in this section.

Multiple monitor modules can be programmed with a MANREL DELAY Type Code. They work like multiple conventional manual release switches on a conventional zone.

### ■ How to program

1. Select a monitor module (refer to “Modify or Delete a Point (2=point)” on page 20) to use for the manual release function.
2. Select the MANREL DELAY Type Code.

PROGRAM	MANREL	DELAY	MODULE	ADDR	EM101	EM101
	R5	--	--	--		

Type Code selection: MANREL\_DELAY

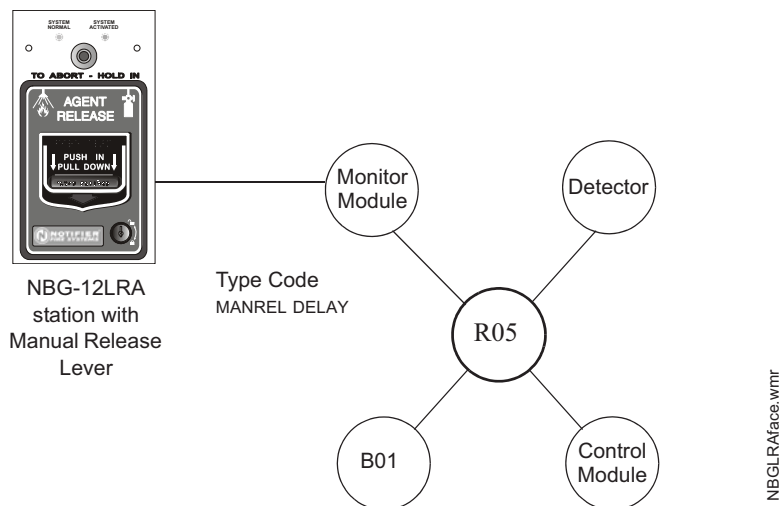
Releasing Zone selection (R5 shown)

3. Select the Releasing Zone (R0-R9) for your releasing application.
4. Press the ENTER key to save, then press the ESC key until you return to the Program Change screen.



## ■ Examples

A programming example of a monitor module programmed for MANREL DELAY switch for Releasing Zone R5.



**Figure 4.12 Monitor Module Configured as a Manual Release Delay Switch**

For examples 1, 2, and 3, program Releasing Zone R5 with a Manual Release Delay switch and the following releasing selections:

```
PRG RELEASE FUNCTION RELEASE CONTROL
DELAY=60 ABORT=ULI CROSS=N SOK=0030 R05
```

**Example 1** - The FACP programmed Delay Timer begins its 60 second countdown. The Manual Release Delay switch is pulled when the FACP Delay Timer has counted down to 48 seconds (elapsed time of 12 seconds). The 48 seconds remaining in the countdown are overridden by the 30-second delay initiated by the Manual Release Delay switch. In this example, the total time elapsing from FACP countdown initiation to agent release is 42 seconds (12 + 30), less than the original 60 second FACP Delay Timer countdown.

**Example 2** - The FACP programmed Delay Time begins its 60 second countdown. The Manual Release Delay switch is pulled when the FACP Delay Timer has counted down to 8 seconds. The 8 seconds remaining in the countdown is not changed when the switch is pulled. In this example, the total time elapsing from FACP countdown initiation to agent release is 60 seconds.

**Example 3** - The FACP programmed Delay Time is not running (as would happen if the releasing station were pulled before an alarm registered). The Manual Release Delay Switch is activated by the pull station. Agent release will occur in 30 seconds.

For examples 4 and 5, the delay is changed to DELAY=10.

**Example 4** - The FACP programmed Delay Timer begins its 10 second countdown. The Manual Release Delay switch is pulled when the FACP Delay timer has counted down to 8 seconds. The 8 seconds remaining in the countdown is not changed. In this example, the total time elapsing from FACP countdown initiation to agent release is 10 seconds.

**Example 5** - The FACP programmed Delay Timer is not running (as would happen if the releasing station were pulled before an alarm registered). The Manual Release Delay switch is activated by the pull station. Agent release will occur in 10 seconds.

## SECOND SHOT Type Code



**NOTE:** The Second Shot switch can only be used with the MANREL DELAY Type Code.

The following contains information needed to program a Second Shot switch for a monitor module

### ■ Description

A monitor module—connected to a UL-listed manual station (such as the NBG-12LRA)—used as for a second release of agents. A Second Shot switch overrides a Delay Timer, programmed to the same Releasing Zone.

### ■ Programming

1. Select a monitor module (refer to “Modify or Delete a Point (2=point)” on page 20) to use for the manual release function.
2. Select the SECOND SHOT Type Code.

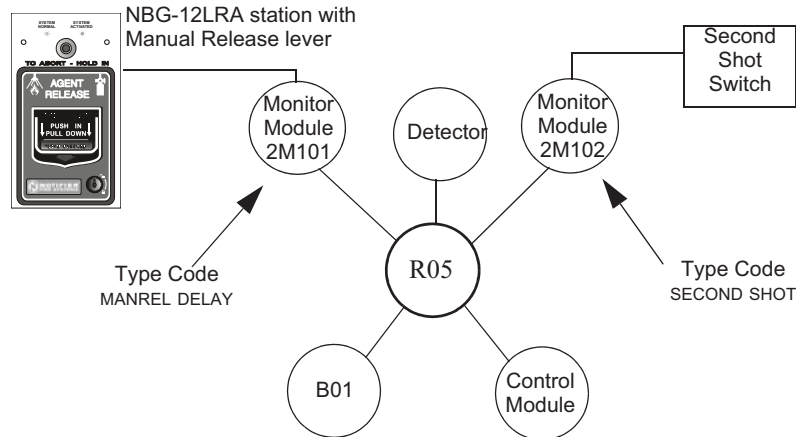
```

Type Code selection: SECOND_SHOT
PROGRAM SECOND_SHOT MODULE ADDR 2M101
R 5 _ _ _ _ _ 2M101
Releasing Zone selection (R5 shown)
    
```

3. Select the Releasing Zone (R0-R9) for your releasing application.
4. Press the ENTER key to save, then press the ESC key until you return to the Program Change screen.

### ■ Examples

A programming example of a monitor module programmed as a Manual Release Delay switch (Type Code MANREL DELAY) for the first shot and a Second Shot switch (Type Code SECOND SHOT) for the second shot.



**Figure 4.13 Monitor Module Configured as a Second Shot Switch**

With two monitor modules configured as shown above, program Releasing Zone R5 with the following releasing selections.

```

PRG RELEASE FUNCTION RELEASE CONTROL
DELAY=15 ABORT=ULI CROSS=Y SOK=0030 R05
    
```

R05 can be activated in one of two ways, as described in the examples given below.

**Example 1:** If the detector initiates the alarm, R05 activates. Releasing begins after the delay timer has expired (15 seconds). Releasing will continue for the soak timer duration (30 seconds). Once the Soak Timer expires, the Second Shot Switch can then be activated to initiate an additional soak cycle.

**Example 2:** If the NBG-12LRA (Type Code MANREL DELAY) lever is pulled, the delay timer begins its 15 second countdown. Releasing will begin after the delay timer has expired, and will continue for the soak timer duration (30 seconds). Once the Soak Timer expires, the Second Shot Switch can then be activated to initiate an additional soak cycle.

**RELEASE END BELL**



**NOTE:** A releasing circuit with this Type Code requires the following selections: A Releasing Zone selection (R0-R9); An output circuit mapped to the same Releasing Zone; Switch Inhibit selected; Non-Silenceable; No Walk Test.

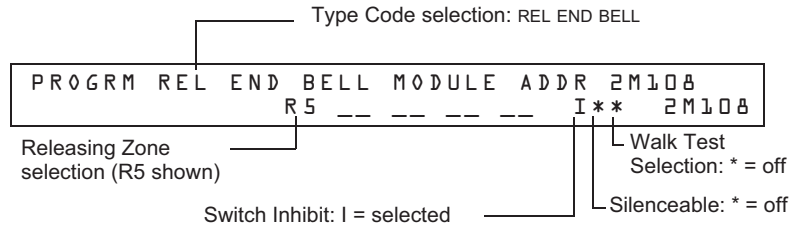
The following contains information needed to program a Release End Bell circuit for a control module or a NAC.

■ **Description**

A control module or NAC to activate an audible or visual device when releasing devices shut off. You can also program multiple outputs with the REL END BELL Type Code to the same Releasing Zone. When all the Releasing Zone functions are complete, all outputs with the REL END BELL Type Code activate at the same time. A rel end bell circuit remains on until you reset the system

■ **Programming**

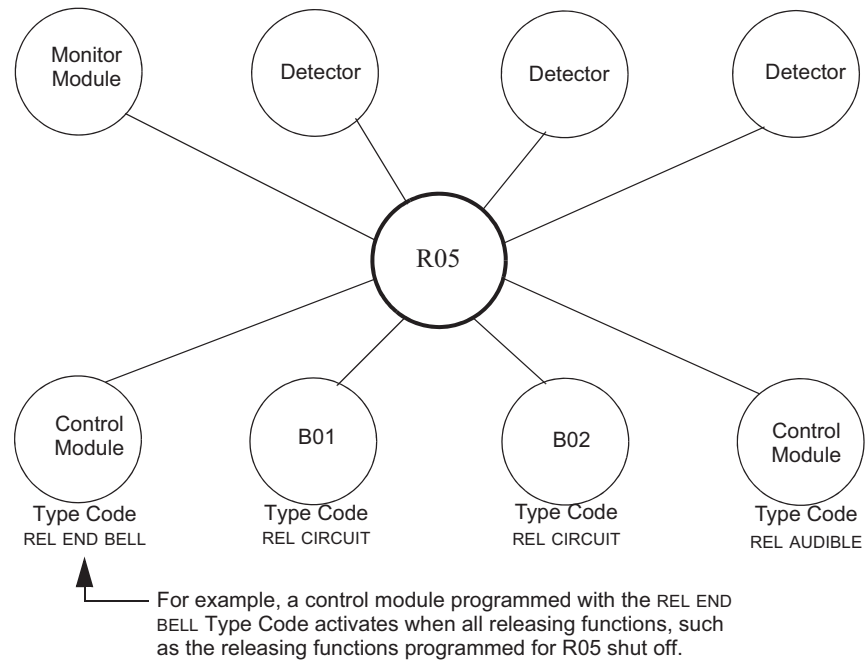
1. Select a control module or NAC (refer to “Modify or Delete a Point (2=point)” on page 20) to use as a Release End Bell circuit.
2. Select the REL END BELL Type Code, as shown in the following example (control module shown).



3. Select the Releasing Zone (R0-R9) for your releasing application.
4. Press the enter key to save, then press the esc key two times to return to the Program Change screen.

### ■ Example

A programming example of a control module programmed as a Release End Bell for Releasing Zone R5.



**Figure 4.14 Control Module Configured as a Release End Bell Circuit**

### REL CKT ULC Type Code



**NOTE:** A ULC Release Circuit with this Type Code requires the following selections: A Releasing Zone selection (R0-R9); An output circuit mapped to the same Releasing Zone; Switch Inhibit selected; Non-Silenceable; No Walk Test.

The following contains information needed to program a ULC Release Circuit for a control module or a NAC.

#### ■ Description

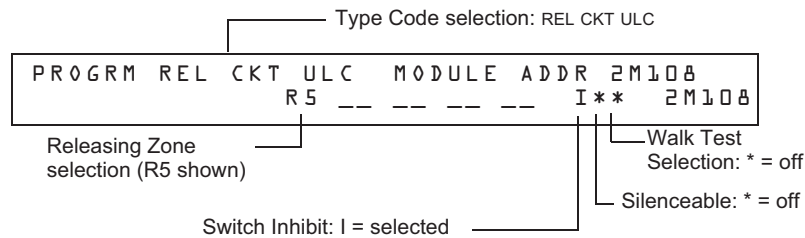
A control module or a NAC used to activate a releasing solenoid or other releasing device. You can also program multiple outputs with the REL CKT ULC Type Code to the same Releasing Zone. When the Releasing Zone activates, all outputs with the REL CKT ULC Type Code also activate at the same time. A ULC Release Circuit activates when:

- An initiating device programmed to the same Releasing Zone activates (two devices if using the Cross Zone option)
- The Delay Timer for R0-R9 (if used) expires
- No Abort Switch for R0-R9 (if used) is active

A ULC Release Circuit—and all wiring to the release device—is fully supervised and usable with power-limited energy cable.

#### ■ Programming

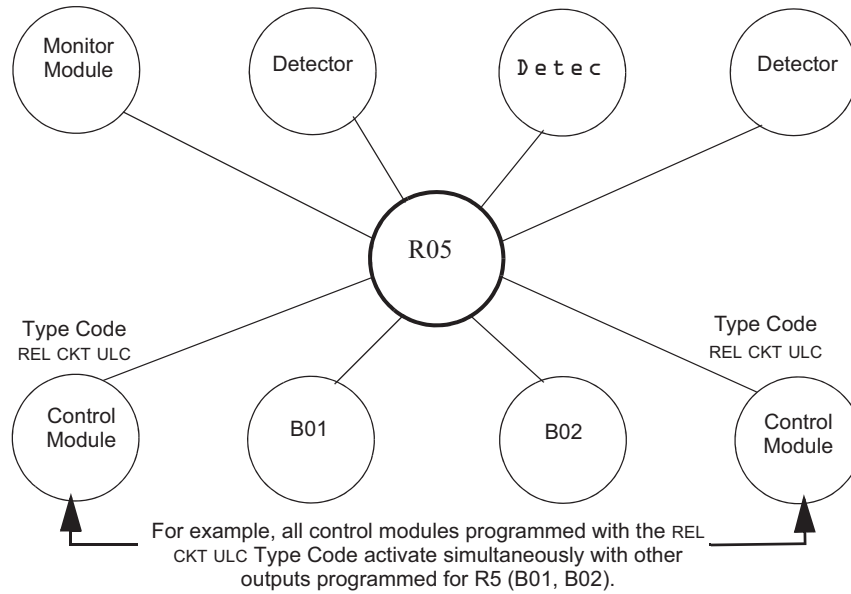
1. Select a control module or a NAC (refer to “Modify or Delete a Point (2=point)” on page 20) to use as a ULC Release Circuit.
2. Select the REL CKT ULC Type Code, as shown in the following example (control module shown).



3. Select the Releasing Zone (R0-R9) for your releasing application.
4. Press the ENTER key to save, then press the ESC key two times to return to the Program Change screen.

■ **Example**

A programming example of a control module programmed as a ULC Release Circuit for Releasing Zone R5.



**Figure 4.15 Control Module Configured as a ULC Release Circuit**

## RELEASE CKT Type Code



**NOTE:** A Release Circuit with this Type Code requires the following selections: A Releasing Zone selection (R0-R9); An output circuit mapped to the same Releasing Zone; Switch Inhibit selected; Non-Silenceable; No Walk Test.



**NOTE:** Do not use a Release Circuit for the following: An application requiring ULC Listing; An application requiring power-limited energy cable.

The following contains information needed to program a Release Circuit for an output circuit (control module or NAC).

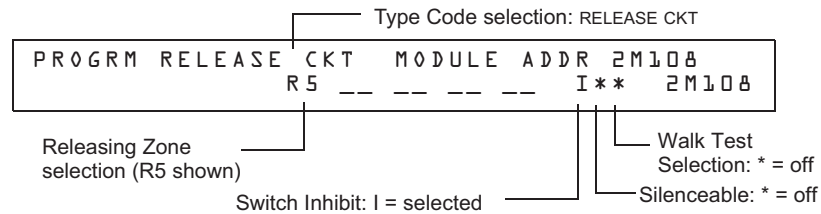
### ■ Description

A control module or a NAC used to activate a releasing solenoid or other releasing device. You can also program multiple outputs with the RELEASE CKT Type Code to the same Releasing Zone. When the Releasing Zone activates, all outputs associated with the releasing zone and with the RELEASE CKT Type Code also activate at the same time. A Release Circuit activates when:

- An initiating device programmed to the same Releasing Zone activates (two devices if using the Cross Zone option)
- The Delay Timer for R0-R9 (if used) expires
- The Abort Switch for R0-R9 (if used) is not active

### ■ Programming

1. Select a control module or a NAC (refer to “Modify or Delete a Point (2=point)” on page 20) to use as a Release Circuit.
2. Select the RELEASE CKT Type Code, as shown in the following example (control module shown).

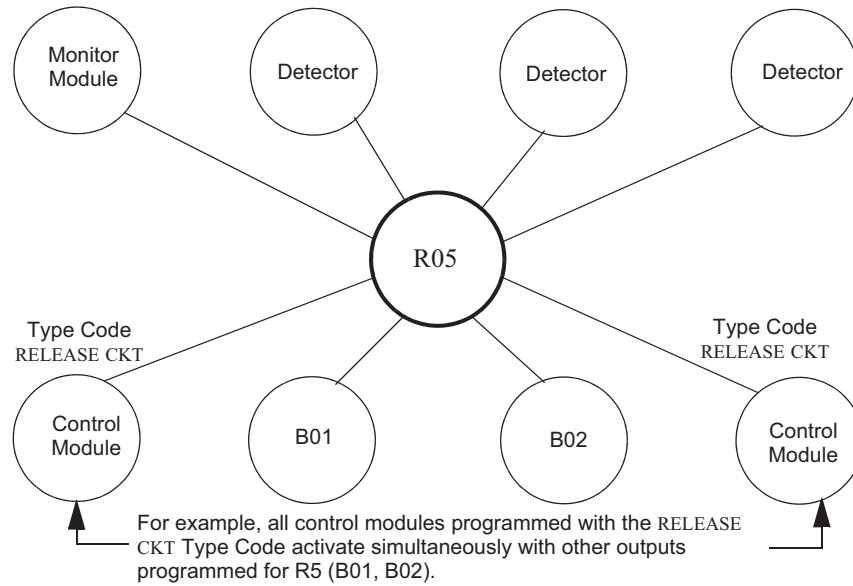


3. Select the Releasing Zone (R0-R9) for your releasing application.
4. Press the ENTER key to save, then press the ESC key two times to return to the Program Change screen.



### ■ Example

A programming example of a control module programmed as a Release Circuit for Releasing Zone R5.



**Figure 4.16 Control Module Configured as a Release Circuit**

## Relea. Form-C Type Code



**NOTE:** An output with a relea.form c Type Code requires the following selections: A Releasing Zone selection (R0-R9); An output circuit mapped to the same Releasing Zone; Switch Inhibit selected; Non-Silenceable; No Walk Test.

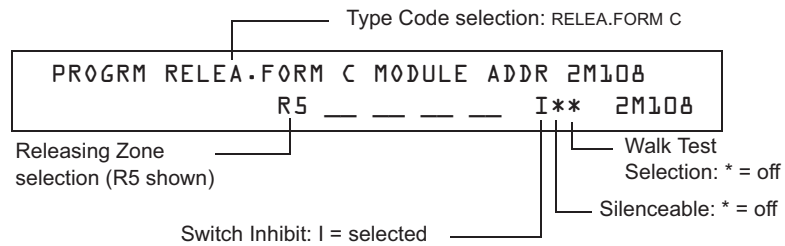
The following contains information needed to program a Release Form-C circuit for an output circuit.

### ■ Description

An output circuit, configured as a relay, programmed to activate an output by opening or closing a switch. Typical applications include closing doors and air handlers.

### ■ Programming

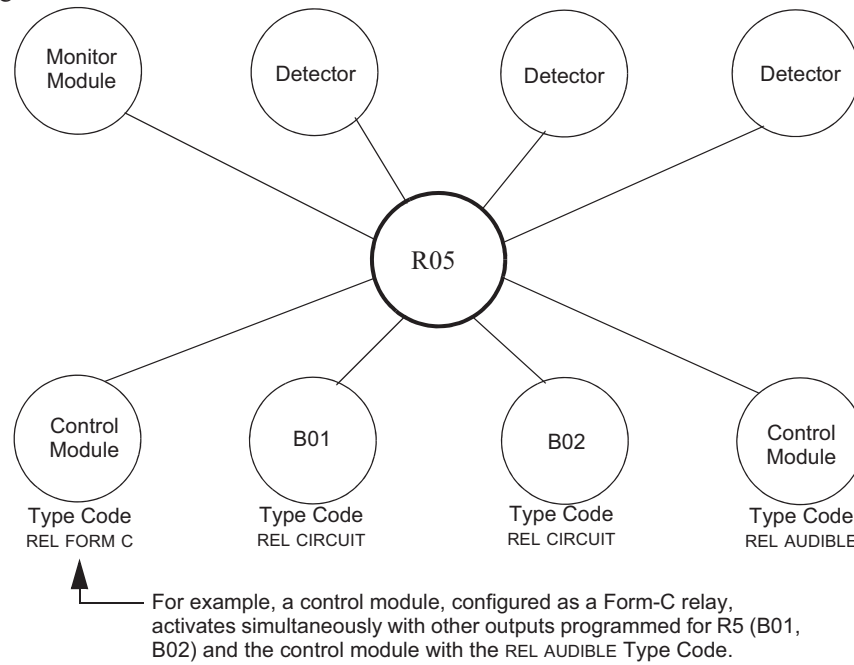
1. Select a control module (refer to “Modify or Delete a Point (2=point)” on page 20) to use as a Releasing Form-C Circuit.
2. Select the RELEA.FORM C Type Code, as shown in the following example (control module shown).



3. Select the Releasing Zone (R0-R9) for your releasing application.
4. Press the ENTER key to save, then press the ESC key two times to return to the Program Change screen.

### ■ Example

A programming example of a control module programmed as a Release Form-C circuit for Releasing Zone R5.



**Figure 4.17 Control Module Configured as a Release Form-C Circuit**

## REL AUDIBLE Type Code



**NOTE:** An output with a REL AUDIBLE Type Code requires the following selections: A Releasing Zone selection (R0-R9); An output circuit mapped to the same Releasing Zone; Switch Inhibit selected.

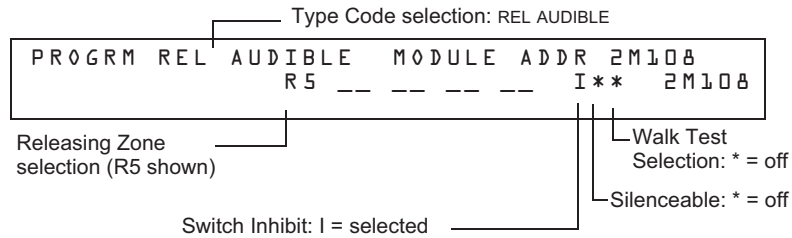
The following contains information needed to program a Release Audible circuit for an output circuit (control module or NAC).

### ■ Description

An output circuit programmed to activate an audio or visual device when all releasing outputs, programmed to the same Releasing Zone, turn on. You can also program multiple outputs with the REL AUDIBLE Type Code to the same Releasing Zone. When the Releasing Zone activates, all outputs with the REL AUDIBLE Type Code activate at the same time.

### ■ Programming

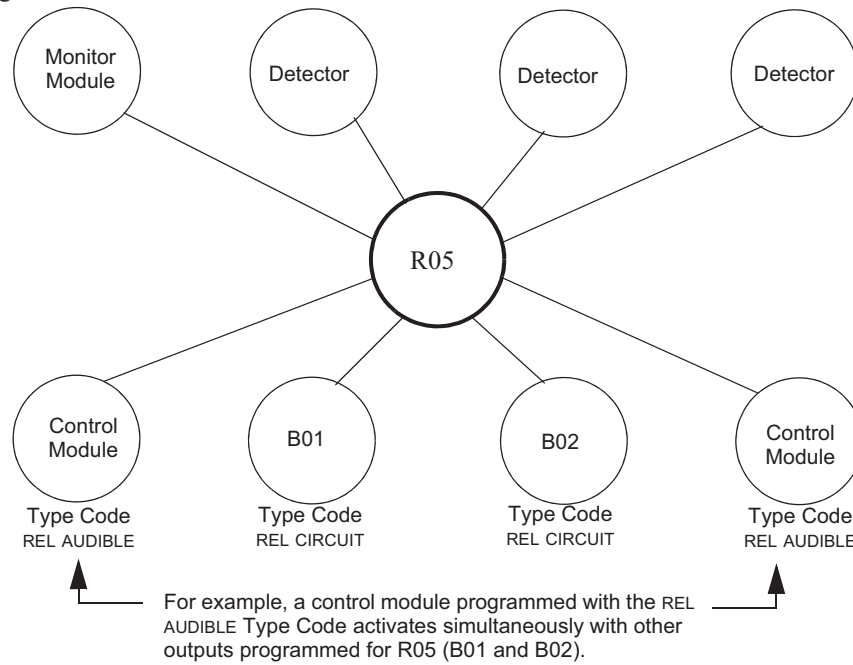
1. Select a control module or NAC (refer to “Modify or Delete a Point (2=point)” on page 20) to use as a Releasing Circuit.
2. Select the REL AUDIBLE Type Code, as shown in the following example (control module shown).



3. Select the Releasing Zone (R0-R9) for your releasing application.
4. Press the ENTER key to save, then press the ESC key two times to return to the Program Change screen.

■ **Example**

A programming example of a control module programmed as a Release Audible circuit for Releasing Zone R5.



**Figure 4.18 Control Module Configured as a Release Audible Circuit**

**INSTANT RELE Type Code**



**NOTE:** An output with an INSTANT RELE Type Code requires the following selections: a zone selection (a releasing zone may be used, but is not required); an output circuit mapped to the same zone; Switch Inhibit selected; Non-Silenceable; No Walk Test.

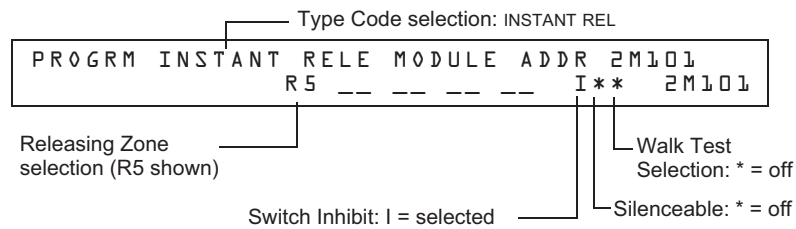
The following contains information needed to program an Instant Release circuit for an output circuit (control module or NAC).

**■ Description**

An output circuit programmed to activate non-releasing devices, such as door openers or warning sounders, without counting down delay timers. A device programmed with the INSTANT RELE Type Code device is supervised for open circuits and ground faults.

**■ Programming**

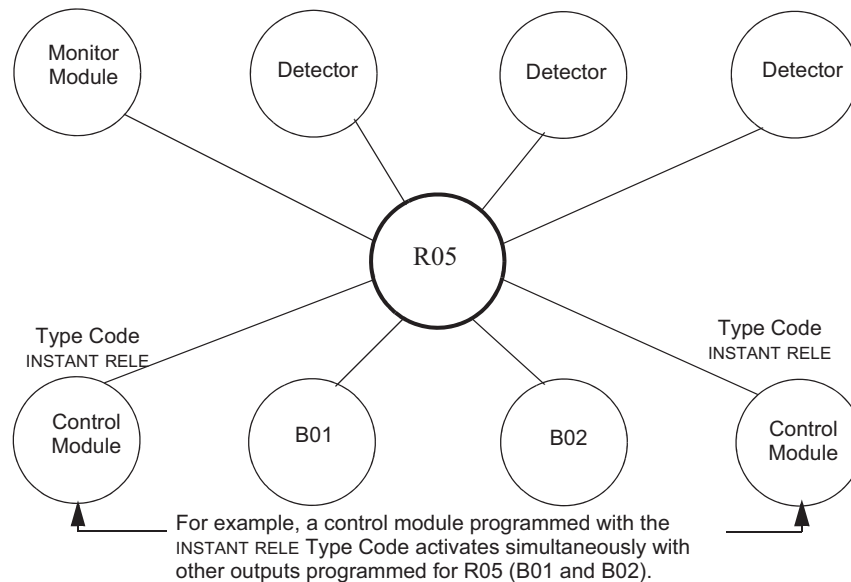
1. Select a control module or a NAC (refer to “Modify or Delete a Point (2=point)” on page 20) to use as a Releasing Circuit.
2. Select the INSTANT RELE Type Code, as shown in the following example (control module shown).



3. Select the Releasing Zone (R0-R9) for your releasing application.
4. Press the ENTER key to save, then press the ESC key two times to return to the Program Change screen.

**■ Example**

A programming example of a control module programmed as an Instant Release circuit for Releasing Zone R5.



**Figure 4.19 Control Module Configured as an Instant Release Circuit**

### REL CODE BELL Type Code



**NOTE:** An output with a REL CODE BELL Type Code requires the following selections: A Releasing Zone selection (R0-R9); An input circuit mapped to the same Releasing Zone.



**NOTE:** For instructions on programming Switch Inhibit, Silenceable, and Walk Test, refer to “Modify NAC Points” on page 25.

The following contains information needed to program a Release Code Bell circuit for a NAC.

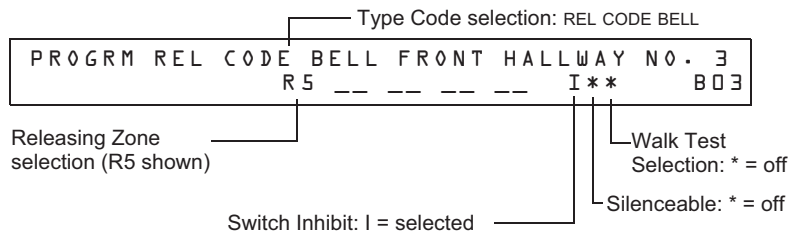
#### ■ Description

A NAC programmed to pulse an audio or visual device as follows:

- 20 ppm when a the initial zone of a cross-zone activates.
- 120 ppm when a Cross Zone is satisfied.
- Steady when a release occurs.

#### ■ Programming

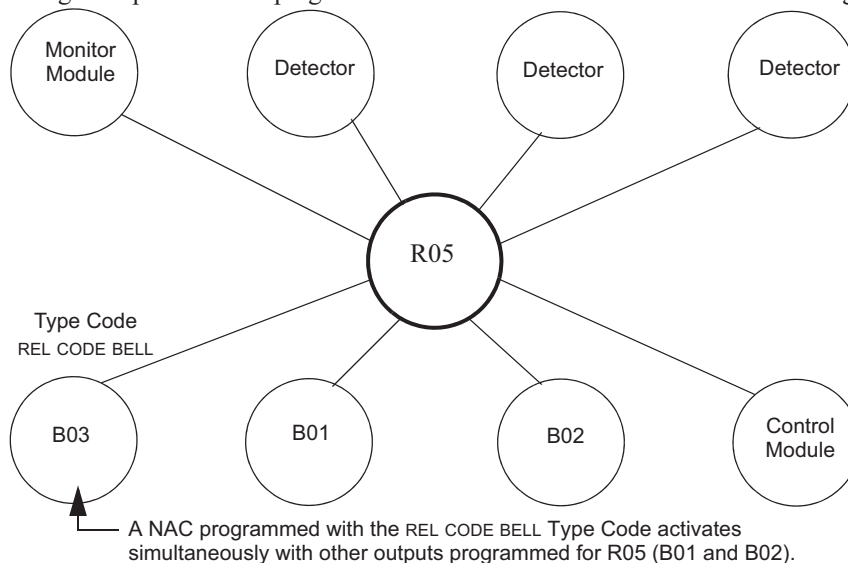
1. Select a NAC (refer to “Modify NAC Points” on page 25) to use as a Release Code Bell Circuit.
2. Select the REL CODE BELL Type Code, as shown in the following example (NAC shown).



3. Select the Releasing Zone (R0-R9) for your releasing application.
4. Press the ENTER key to save, then press the ESC key two times to return to the Program Change screen.

#### ■ Example

A programming example of a NAC programmed as a Release Code Bell circuit for Releasing Zone R5.



**Figure 4.20 NAC Configured as a Release Code Bell Circuit**

## 4.3 Initiating Devices

Releasing zone initiating devices include the following:

- FST-851 intelligent heat detectors
- FSI-851, FSP-851, FAPT-851, FSL-751 intelligent smoke detectors
- Conventional detection UL-listed devices connected to monitor modules

Refer to the SLC manual for the most up-to-date information about initiating devices.

You can use multiple initiating devices for the same releasing hazard. Do so by mapping initiating devices to the same Releasing Zone. Factory Mutual and certain Local Authorities Having Jurisdiction require using redundant wiring (NFPA 72 Style 6 or Style D) for initiating devices in releasing applications.

## 4.4 Warning Sounders

Warning sounders connect to any of the four panel NACs, or to control module circuits (refer to the *NF2S-640 Installation Manual*). Note the following:

- If selecting Cross Zones, a warning sounder only activates when two zones alarm.
- Warning sounders—unlike release solenoids—do not wait for a Delay Timer.
- If Coding Functions are required for warning sounders, use one of the NACs—not a control module.
- The same releasing hazard can activate multiple NACs.

Instructions for activating warning sounders:

To activate a sounder	Do this
When the Delay Timer starts, when the releasing device activates, or both	Map the control module or NAC to a releasing hazard zone (R0-R9).
Immediately when one of the initiating devices activate	Map the control module or NAC to a separate zone (not R0-R9) that is also mapped to all initiating devices of the hazard.

## 4.5 Auxiliary Control Functions

Instructions for using control functions:

Function	Do this
A releasing application requires control relays	Use control modules set for dry contact operation. Program the control relays for different functions by following the instructions in “To activate a sounder” above.
Providing control functions	Use an ACM-8R remote relay module mapped to the software zones of the control panel.

## 4.6 ACS Annunciation

Instructions for annunciating ACS points and detectors:

To Annunciate	Do this
Points of releasing functions	Select ACS Selection Group B to annunciate any of the software zones described previously, including zones R0-R9. For instructions, refer to “Annunciator Options” on page 33.
Individual detectors	Select ACS Selection Group H, I, J, K or L. For instructions, refer to “Annunciator Options” on page 33.



# Appendix 5: Special Zone Outputs

## 5.1 Presignal and Positive Alarm Sequence (PAS)

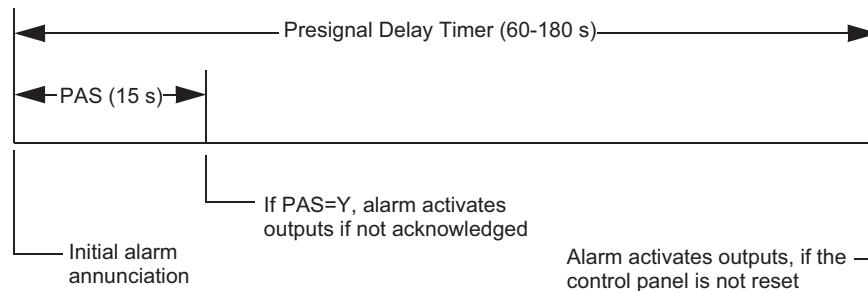
### 5.1.1 What is Presignal and PAS?

#### Purpose

Presignal is a feature that initially causes alarm signals to only sound in specific areas, monitored by qualified persons. This allows delay of the alarm up to 180 seconds after the start of alarm processing. The control panel Presignal feature provides two selections:

- A **Presignal Delay Timer** (60-180 seconds) that delays activation of all outputs with a CBE that includes Special Zone F0.
- A **PAS** (Positive Alarm Sequence) selection, in addition to the **Presignal Delay Timer**, that allows a 15-second time period for acknowledging an alarm signal from a fire detection/initiating device. If the alarm is not acknowledged within 15 seconds, all local and remote outputs activate immediately and automatically.

An illustration of Presignal and PAS timing.



**Figure 5.1 Presignal and PAS Time**

The control panel delays activation of outputs containing F0 in their Control-By-Event (CBE) list for all alarm initiating devices that contain F0 in their CBE list. A subsequent alarm will abort the Presignal Delay Timer and execute CBE lists.

#### Notes on using F0

- NFPA 72 requires installation of a PAS Inhibit switch, that can be used to turn off the PAS delay timer when the control panel is unattended. Do so by programming a monitor module with the Type Code, PAS INHIBIT. For details, refer to “Modify an Addressable Monitor Module Point” on page 22.
- The Presignal Delay timer countdown can be stopped by pressing the SYSTEM RESET key before the Presignal Delay Timer expires.
- Program zone F0 to participating inputs and outputs that have appropriate CBE zone map entries.

#### Restrictions on using F0

- Do not include F0 in the CBE list for a releasing device.
- Do not include F0 in the CBE list for any monitor module that connects to a device other than an automatic fire detector.

## 5.1.2 Selecting Presignal and PAS Outputs

### Presignal

You can set Presignal Delay Timer between 60 and 180 seconds. A Presignal Delay Timer does not apply to the following:

- The System Alarm relay
- TM-4 polarity reversal alarm output
- TM-4 municipal box output
- UDACT

### Positive Alarm Sequence (PAS)

Outputs selected for PAS delay for 15 seconds. Pressing the ACKNOWLEDGE/SCROLL DISPLAY key within the 15-second delay will set the Presignal Delay Timer to the full programmed value (60-180 seconds, including the PAS delay of 15 seconds). When an alarm comes from an initiating device with a CBE list that includes F0, the control panel delays the following outputs:

- System Alarm relay
- TM-4 Polarity Reversal Alarm output
- TM-4 Municipal Box output
- UDACT

## 5.2 Time Control Zones



---

**NOTE:** All active Time Control outputs will turn off temporarily while resetting or programming the control panel

---

All outputs with a CBE list containing F5 or F6 activate within the times specified for the days of the week listed in F5 or F6. All smoke detectors with a CBE list containing F5 or F6 switch to their occupied level (lowest sensitivity, AL:9) within the times specified for the days of the week listed in ZF5 or ZF6. Refer to “Intelligent Sensing Applications” on page 91 for details on setting detector sensitivity.

Time Control is active for all days of the week listed in F5 or F6. Holidays listed in F7 are excluded unless you list Holidays (H) in the day-of-week selection of F5 and F6. Enter the time in a 24-hour format with the OFF time later than the ON time. After changing programming using Time Control, always reset the control panel.

## 5.3 Coding Functions for NACS

Coding Functions are pulsed signals that can be selected, using Special Zone F8, to energize NACs when a fire alarm activates. NACs must be programmed with a CBE list that includes F8.



---

**NOTE:** Do not include F8 in the CBE list of NACs used for releasing or zone coding applications.

---

Select Coding Functions on a global basis, through Special Zone F8. That is, all NACs selected for Coding Functions will sound the same code when activated. The table below contains descriptions of each Coding Function selection:

Coding Function Selection	Signal
March Time (default)	120 PPM (pulses per minute)
Temporal	0.5s on, 0.5s off, 0.5s on, 0.5s off, 0.5s on, 1.5s off, repeats
California	10 sec. on, 5 sec. off, repeats
Two-stage	Alert signal - 20 PPM; General Alarm Signal - Temporal
Two-Stage Canada 3	Alert Signal - 20 PPM; Drill Switch activated - Temporal (3 min. timeout)
Two-Stage Canada 5	Alert Signal - 20 PPM; Drill Switch activated - Temporal (5 min. timeout)
System Sensor Strobe	Synchronizes System Sensor Horn/Strobes (Applies to NAC on CPU2-640 only) <b>Note:</b> If the "Strobe" Type ID is used with System Sensor Strobe synchronization, "*" will silence the horn portion only, and resound will occur only by fire alarm. F, U, B, T, or O will silence the entire circuit. Refer to "Modify an Addressable Control Module Point" on page 23 and "Modify NAC Points" on page 25
Gentex Strobe	Synchronizes Gentex Horn/Strobes (Applies to NAC on CPU2-640 only) <b>Note:</b> If the "Strobe" Type ID is used with Gentex Strobe synchronization, "*" will silence the horn portion only, and resound will occur only by fire alarm. F, U, B, T, or O will silence the entire circuit. Refer to "Modify an Addressable Control Module Point" on page 23 and "Modify NAC Points" on page 25
Wheelock Strobe	Synchronizes Wheelock Horn/Strobes (Applies to NAC on CPU2-640 only) <b>Note:</b> If the "Strobe" Type ID is used with Wheelock Strobe synchronization, "*" will silence the horn portion only, and resound will occur only by fire alarm. F, U, B, T, or O will silence the entire circuit. Refer to "Modify an Addressable Control Module Point" on page 23 and "Modify NAC Points" on page 25

**Table 5.1 Coding Function Selections**

Before selecting an output for Two-stage coding, note the following:

The control panel automatically sends an Alert Signal to any of the four NACs mapped to Z00 and F8, but not mapped to the alarm signal. After five minutes without an acknowledge or silence, the Alert Signal changes to Temporal pattern.

Two-stage Canada 3 and 5: Function the same as Two-stage except the second stage is achieved when

- The three or five minute timer expires without an acknowledge or silence.

**OR**

- The Drill Switch (or an input programmed with the type code DRILL SWITCH or EVACUATE SW) is activated.

If Acknowledge or Silence is pressed within the three or five minute timeout period, the NAC will remain at first stage. Subsequent alarm(s) will restart the timer.

# Appendix 6: Intelligent Sensing Applications

## 6.1 Overview

“Intelligent Sensing” is a set of software algorithms that provide the *NF2S-640* with industry-leading smoke detection capability. You can program Intelligent Sensing functions on a global or on a per-detector basis.

Intelligent Sensing topics covered in this appendix:

Topic	Page
<b>Intelligent Sensing Applications features</b> – Descriptions of features, such as Drift Compensation, Sensitivity Adjust, programmable on a per-detector basis.	page 91
<b>Pre-Alarm</b> – Alert and Action settings, programming (global settings).	page 96
<b>Detector Sensitivity Settings</b> – Pre-Alarm and Alarm sensitivity settings for photo, ion, laser, and multisensor detectors programmable on a per-detector basis.	page 97
<b>Detector Maintenance Features</b> – Instructions for viewing and printing detector maintenance information.	page 99

## 6.2 Features

Intelligent Sensing Applications features include the following:

- Drift Compensation and Smoothing
- Maintenance Warnings - Three Levels
- Self-optimizing Pre-Alarm
- Detector Sensitivity
- Cooperative Multi-Detector Sensing

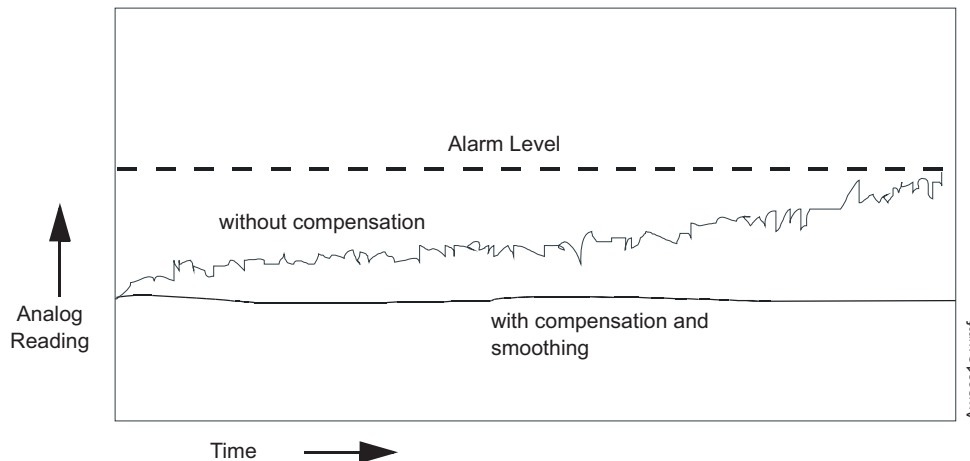
### 6.2.1 Drift Compensation and Smoothing

Drift compensation uses algorithms (U.S. patent pending) that identify and compensate for long-term changes in the analog readings from each smoke detector. (Typically, dirt and dust accumulation inside the smoke chamber causes long-term changes in detector readings.) Drift compensation does the following:

- Allows a detector to retain its original ability to detect actual smoke, and resist false alarms, even as dirt and dust accumulates.
- Reduces maintenance requirements by allowing the control panel to automatically perform the periodic sensitivity measurements required by NFPA Standard.

The software also provides smoothing filters to remove transient noise signals, usually caused by electrical interference. Different smoothing algorithms are used, depending on the sensitivity selection of each detector. Refer to “Detector Sensitivity Settings” on page 97 for more information on detector sensitivity levels.

A graphic representation of a detector analog reading using drift compensation and smoothing:



**Figure 6.1 Graphic Representation of Drift Compensation**

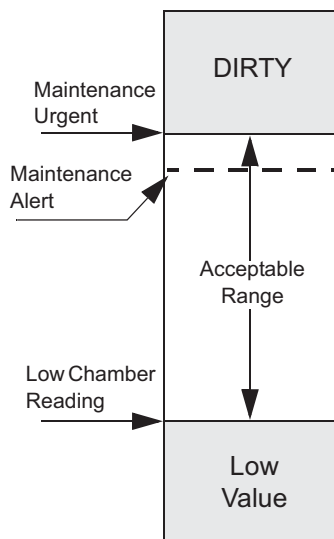
### 6.2.2 Maintenance Warnings – Three Levels

The software determines when the drift compensation for a detector reaches an unacceptable level that can compromise detector performance. When a detector reaches an unacceptable level, the control panel indicates a maintenance warning. The table below summarizes the three levels of maintenance warnings:

Maintenance Level	Indicates
Low Chamber value	A hardware problem in the detector.
Maintenance Alert	Dust accumulation that is near but below the allowed limit. The Maintenance Alert level indicates the need for maintenance before the performance of the detector is compromised.
Maintenance Urgent	Dust accumulation above the allowed limit.

**Table 6.1 Definitions of Maintenance Levels**

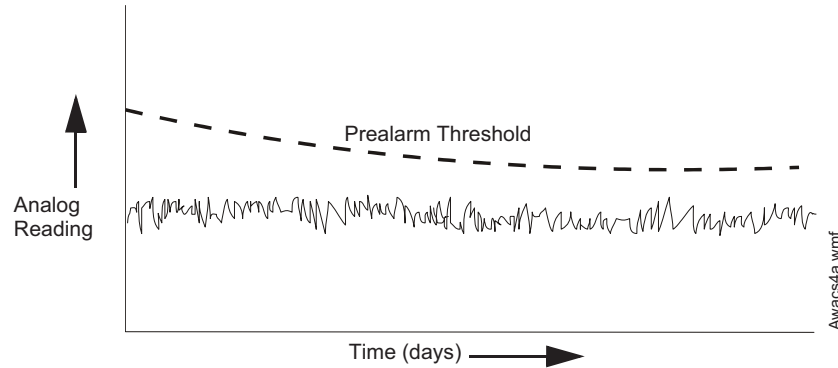
A graphic representation of the maintenance levels:



**Figure 6.2 Diagram of Maintenance Levels**

### 6.2.3 Self-Optimizing Pre-Alarm

You can set each detector, except (Heat), for Self-Optimizing Pre-Alarm (PA=1). In this Self-Optimizing mode, the software measures the normal peak analog readings and sets the Pre-Alarm level just above these normal peaks. This allows extremely sensitive Pre-Alarm capability with reasonable protection against non-fire signals. The figure below shows a graphical representation of the Self-Optimizing Pre-Alarm level:



**Figure 6.3 Self-optimizing Pre-Alarm Level**

For more information on setting Pre-Alarm levels, refer to “Changing Detector Sensitivity” on page 49

### 6.2.4 Detector Sensitivity

The control panel provides nine Sensitivity Levels for alarm detection and pre-alarm as follows:



**NOTE:** For a list of all detector sensitivity levels, see Table 6.2 on page 97.

- **Alarm Sensitivity Levels** - Select the sensitivity of a detector from 1-9 (1=highest sensitivity; 9=lowest sensitivity).
- **Pre-Alarm Sensitivity Levels** - Select one of nine levels from 1 to 9 (0=no Pre-Alarm, 1=self-optimizing, 2=highest sensitivity, 9=lowest sensitivity). You can set Pre-Alarm operation to Action (latching) or Alert (non-latching) and to activate Special Zones. For instructions on programming, refer to “How to Select a Pre-Alarm Level” on page 96.

Set the sensitivity levels as fixed or programmed for day and night operation. For details, refer to “Time Control Zones” on page 89.

A sample sensitivity window for a laser detector:

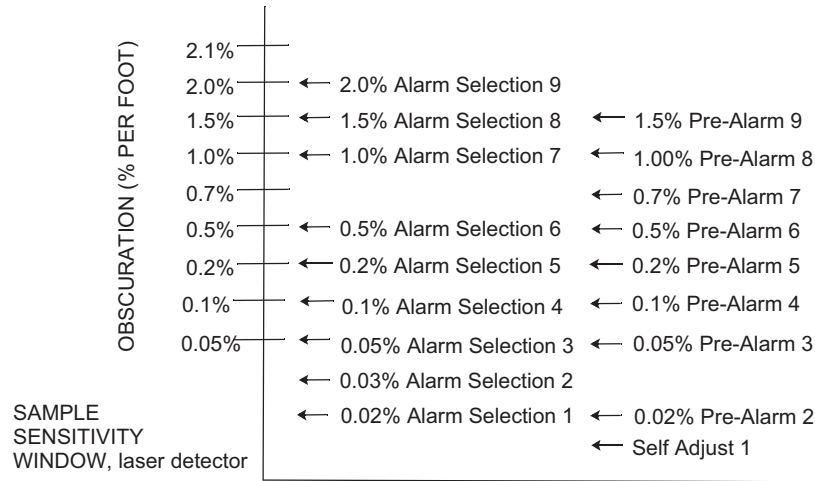


Figure 6.4 Sensitivity Levels for a FlashScan View® Laser Detector

### 6.2.5 Cooperative Multi-Detector Sensing

Cooperative Multi-Detector Sensing is the ability of a smoke detector to consider readings from nearby detectors in making alarm or pre-alarm decisions. Each detector can include up to two other detectors in its decision. Without statistical sacrifice in the ability to resist false alarms, Cooperative Multi-Detector Sensing allows a detector to increase its sensitivity to actual smoke by a factor of almost 2 to 1. Cooperative Multi-Detector Sensing also allows the combination of ionization with photoelectric technology in reaching an alarm decision. The figure below shows a graph representing Cooperative Multi-Detector Sensing:

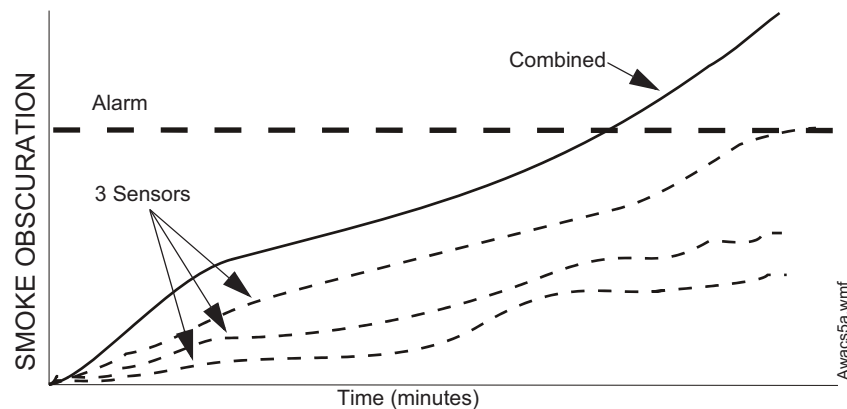


Figure 6.5 Cooperative Multi-Detector Sensing

## 6.3 Pre-Alarm

### 6.3.1 Definition

The Pre-Alarm function is a programmable option which determines the system's response to real-time detector sensing values above the programmed setting. Use the Pre-Alarm function if you want to get an early warning of incipient or potential fire conditions. There are two levels of Pre-Alarm:

- Alert (Refer to “Alert Level” below)
- Action (Refer to “Action Level” on page 96)

Alert and Action Pre-Alarm settings are global. For instance, if you program Pre-Alarm for Alert, all intelligent detectors programmed for Pre-Alarm are set to Alert (refer to “How to Select a Pre-Alarm Level” on page 96). You can, however, set unique Pre-Alarm sensitivity levels (PA) for individual detectors (refer to “Detector Sensitivity Settings” on page 97).

### 6.3.2 Alert Level

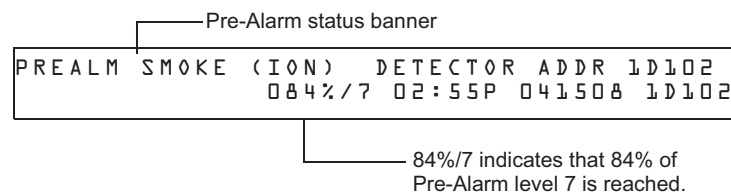
#### Alert Functions

The control panel software, in addition to checking for alarm levels, checks for Pre-Alarm thresholds for each addressable, intelligent smoke detector programmed for Pre-Alarm. If a detector's real-time sensing level exceeds the programmed Alert threshold, the control panel indicates an Pre-Alarm condition for the detector. The control panel does the following functions when a detector reaches pre-alarm level:

- The Pre-Alarm message is sent to the History buffer and to any installed FDU-80s and printers. The message is sent (and time stamped) at the time that it first occurred. This historical data could provide valuable information about the progress of a fire.
- The PRE-ALARM LED flashes and the panel sounder pulses until acknowledged.
- Zone F9 activates—but Zone 00 (general alarm) or any other zone, System Trouble relay and System Alarm relay do not activate.
- The Pre-Alarm indication for this detector will restore automatically to normal if its sensitivity, programmable to one of nine settings, drops below pre-alarm level. Zone F09 clears automatically when no Pre-Alarm conditions exist.
- A subsequent alarm for this detector also clears the Pre-Alarm indication.

#### Example of an Alert Level

When an ion detector is programmed for AL:7 and PA:5 (covered in “Changing Detector Sensitivity” on page 49), an Alert Pre-Alarm occurs at measured smoke detector levels that exceed 1.00% per foot obscuration. When this happens the panel sounder and the PRE-ALARM LED pulse, and a display appears on the LCD, similar to the sample screen shown below:



**Figure 6.6 Sample Display of a Pre-Alarm Alert Condition**



### 6.3.3 Action Level

#### Action Functions

If you program a detector for Action Pre-Alarm and the detector reaches a level that exceeds the programmed Pre-Alarm level, the control panel indicates an Action condition. Indication at the panel is the same as in Figure 6.6 above. The control panel does the following functions when a detector reaches the programmed pre-alarm level:

- The Action message is sent to the History buffer and to any installed FDU-80s and printers. The message is sent (and time stamped) only at the time that it first occurred. This historical data could provide valuable information about the progress of a fire.
- The PRE-ALARM LED and panel sounder pulse until acknowledged.
- Zone F09 is activated—but Zone Z00 (general alarm or any other zone) and the System Trouble and System Alarm relays do not activate.
- The fifth zone programmed (not the first four) for this detector activates. The fifth zone is the right-most entry on line two of the detector CBE list in the Point Programming screen. (For more information, refer to “Modify an Addressable Detector Point” on page 21). You can use the fifth zone to control functions of a detector or group of detectors once the pre-alarm level is reached. Fifth zone activations also allow ACS annunciation by a detector or group of detectors in Action Pre-Alarm condition.
- The Pre-Alarm condition and the zone programmed will latch until system reset, even if the sensitivity drops below the pre-alarm level.
- A subsequent alarm condition for this detector clears the Action indication from the LCD display alarm list.

### 6.3.4 How to Select a Pre-Alarm Level

Instructions and sample displays to program Pre-Alarm for Alert or Action

1. At the “Enter Password” screen, enter your Program Change Password to display the “Program Change Selection” screen. Press **1** to enter the “Basic Program” screen:

```
0 = CLR  1 = AUTO  2 = POINT  3 = PASSWD  4 = MESSAGE
5 = ZONES  6 = SPL FUNCT  7 = SYSTEM  8 = CHECK PRG
```

6 = SPL FUNCT

2. From the “Basic Program” screen, press the **6** key to display the “Special Function Zone Change” screen.

```
SPECIAL FUNCTION: F0 = PRESIG  R0 - R9 = REL
F5 - F6 = TIME  F7 = HOL  F8 = CODE  F9 = PRE-ALARM
```

F9 = PRE-ALARM

3. From the “Special Function Zone Change” screen, press **F9** to display the “Pre-Alarm Function” screen, with Alert blinking.

```
PRG  PRELARM  FUNCT  ALERT
                                F09
```

ALERT blinking

4. To select Action, press the **+** (Next Selection) or **-** (Previous Selection) key.

```
PRG  PRELARM  FUNCT  ACTION
                                F09
```

ACTION blinking

## 6.4 Detector Sensitivity Settings

### 6.4.1 How to Select Pre-Alarm and Alarm Sensitivity

Each detector provides a host of selectable intelligent options. The control panel provides nine levels of Pre-Alarm (PA:1–PA:9) and Alarm (AL:1–AL:9) in percent per foot obscuration:

- **PA:0** no Pre-Alarm selection.
- **PA:1** usually the self-optimizing setting where the control panel selects a suitable Pre-Alarm level for a detector.
- **PA:2–PA:9** the detector Pre-Alarm sensitivity level - with PA:2 the most sensitive and PA:9 the least sensitive.
- **AL:1–AL:9** the detector Alarm sensitivity level - with AL:1 the most sensitive and AL:9 the least sensitive.



**NOTE:** (d) Signifies the factory default setting in Table 6.2.

Detector Type	Alarm (FlashScan)	Alarm (CLIP)	Pre-Alarm
Photo Electric SMOKE (PHOTO)  (See note <sup>*</sup> )	AL:1=0.50 % AL:2=0.73 % AL:3=0.96 % AL:4=1.19 % AL:5=1.43 % AL:6=1.66 % AL:7=1.89 % AL:8=2.12 % (d) AL:9=2.35 %	AL:1=0.50 % AL:2=0.73 % AL:3=0.96 % AL:4=1.19 % AL:5=1.43 % AL:6=1.66 % AL:7=1.89 % AL:8=2.12 % (d) AL:9=2.35 %	PA:1=Auto PA:2=0.30 % PA:3=0.47 % PA:4=0.64 % PA:5=0.81 % PA:6=0.99 % PA:7=1.16 % PA:8=1.33 % (d) PA:9=1.50 %
Ion SMOKE (ION)  (See notes <sup>*</sup> and <sup>†</sup> )	AL:1=0.50 % AL:2=0.75 % AL:3=1.00 % AL:4=1.25 % AL:5=1.50 % AL:6=1.75 % (d) AL:7=2.00 % AL:8=2.25 % AL:9=2.50 %	AL:1=0.50 % AL:2=0.75 % AL:3=1.00 % AL:4=1.25 % AL:5=1.50 % AL:6=1.75 % (d) AL:7=2.00 % AL:8=2.25 % AL:9=2.50 %	PA:1=Auto PA:2=0.40 % PA:3=0.50 % PA:4=0.75 % PA:5=1.00 % PA:6=1.25 % (d) PA:7=1.50 % PA:8=1.75 % PA:9=2.00 %
FlashScan View <sup>®</sup> Laser  (See Note <sup>‡</sup> )	AL:1=0.02 % AL:2=0.03 % AL:3=0.05 % AL:4=0.10 % AL:5=0.20 % AL:6=0.50 % (d) AL:7=1.00 % AL:8=1.50 % AL:9=2.00 %	AL:1=0.02% AL:2=0.03 % AL:3=0.05 % AL:4=0.10 % AL:5=0.20 % AL:6=0.50 % (d) AL:7=1.00 % AL:8=1.50 % <sup>**</sup> AL:9=2.00 %	PA:1=Auto PA:2=0.02 % PA:3=0.05 % PA:4=0.10 % PA:5=0.20 % PA:6=0.50 % (d) PA:7=0.70 % PA:8=1.00 % PA:9=1.50 %
Acclimate Plus <sup>™</sup>  (See Note <sup>††</sup> )	AL:1=0.50 % AL:2=1.00 % AL:3=1.00 to 2.00 % AL:4=2.00 % AL:5=2.00 to 3.00% (d) AL:6=3.00 % AL:7=3.00 to 4.00 % AL:8=4.00 % AL:9=thermal 135°F	Alarm (CLIP) AL:1=1.00 % AL:2=1.00 % AL:3=1.00 to 2.00 % AL:4=2.00 % AL:5=2.00 to 4.00% (d) AL:6=2.00 to 4.00% AL:7=2.00 to 4.00% AL:8=4.00 % AL:9=4.00%	PA:1=0.50% PA:2=1.00 % PA:3=1.00 % PA:4=1.00 to 2.00% PA:5=1.00 to 2.00 % (d) PA:6=2.00 % PA:7=2.00 % PA:8=2.00 to 3.00 % PA:9=2.00 to 3.00 %
Beam Detector  (See Note <sup>‡‡</sup> )	AL:1=25% AL:2=30% AL:3=40% AL:4=50% AL:5=30 - 50% AL:6=40 - 50%	AL:1=25% AL:2=30% AL:3=40% AL:4=50% AL:5=30 - 50% AL:6=40 - 50%	N/A

**Table 6.2 Detector Sensitivity (in percent obscuration per foot) (1 of 2)**

Detector Type	Alarm (FlashScan)	Alarm (CLIP)	Pre-Alarm
FSC-851 IntelliQuad Detector <sup>***</sup>	AL:1=1% AL:2=2% AL:3=3% AL:4=3% w/ 10 minute confirmation <sup>†††</sup> AL:5=4% w/ 10 minute confirmation AL:6=Thermal 135°F AL:7=Thermal 135°F AL:8=Thermal 135°F AL:9=Thermal 135°F		PA:1=1% PA:2=1% PA:3=2% PA:4=3% PA:5=3% w/ 10 minute confirmation PA:6=4% w/ 10 minute confirmation PA:7=4% w/ 10 minute confirmation PA:8=4% w/ 10 minute confirmation PA:9=4% w/ 10 minute confirmation

**Table 6.2 Detector Sensitivity (in percent obscuration per foot) (2 of 2)**

\* Detectors are suitable for open area protection within the listed air velocity range. Typically, this range is 0 - 4,000 ft/min for photoelectric detectors and 0 - 1,200 ft/min for ionization detectors. Be sure to confirm this range before installing the detector by referring to the manufacturer's installation instructions.

† Use only alarm sensitivity setting of AL=1, AL=2 or AL=3 for ION detectors installed in Canada.

‡ The use of alarm sensitivities below 0.50% obscuration per foot requires a 90 day test to ensure that the environment for the detectors is suitable for the higher sensitivity setting. (Refer to "How to Test Detectors Set Below 0.50% Obscuration per Foot" on page 98.)

\*\* 1% maximum on CLIP. Higher figures may display.

†† For Acclimate detectors installed in Canada: Use only the alarm settings of AL:1 or AL:2.

‡‡ Refer to the beam detector manual to determine the alarm settings: they are a function of the distance between the detector and its reflector.

\*\*\* In CLIP mode, any AL: settings over AL:5 will be set to AL:5 by the panel. Any PA: settings over PA:5 will be set to PA:5 by the panel.

††† Within the 10 minute fire signature confirmation delay period if there is a detection of another fire signature (Carbon Monoxide, Infrared or Thermal) it overrides the 10 minute confirmation time.

## 6.4.2 How to Test Detectors Set Below 0.50% Obscuration per Foot

Using alarm sensitivities below 0.50% obscuration per foot requires a 90-day test to ensure that the detector environment is suitable for the higher sensitivity setting. To meet Notifier and Underwriters Laboratory requirements, test each detector planned to operate below 0.50%/ft obscuration as follows:

1. Set the detector as follows:

Step	Action
1	Initially set to the 0.50% obscuration per foot Alarm level.
2	Set the Pre-Alarm level to the desired final Alarm sensitivity.
3	Set the Pre-Alarm to Alert mode (non-latching).

2. Operate detectors continuously for 90 days with all environmental factors (such as, temperature, humidity, air flow, occupancy, and so on) similar to the intended application for the detectors. Record all events for each tested detector with an electronic History buffer or a printout.
3. At the end of the 90-day test: An authorized Notifier representative, or an end user trained by an authorized Notifier representative must inspect the results of the test. If the test results show no alarms or pre-alarms for the tested detectors, reprogram the fire alarm system to set the Alarm sensitivity to the more sensitive Pre-Alarm level of the test.

## 6.5 Detector Maintenance Features

### 6.5.1 Overview

The NF2S-640 provides features to check the maintenance performance level of addressable, intelligent detectors. Detector maintenance features include the following:

- View detector maintenance information for an individual detector
- Print a detector maintenance report for all detectors

### 6.5.2 How to Access Detector Maintenance Information

1. Access detector maintenance functions by pressing the ENTER key. The control panel displays the Program Entry screen:

```

┌=PROGRAMMING           2=READ STATUS ENTRY
(ESCAPE TO ABORT)
    
```

2. At the Program Entry screen, press the M key. The control panel displays the Detector Maintenance Selection screen:

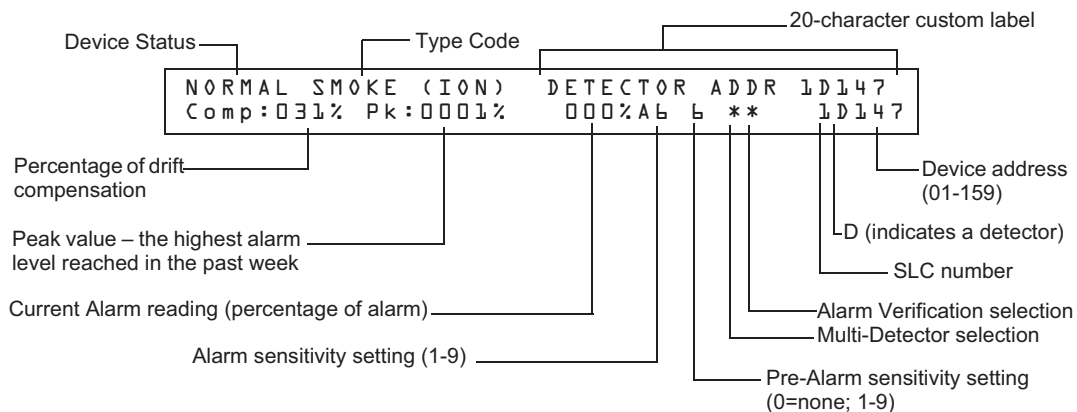
```

SLC loop _____ Three digit address
Select Detector Address (LDAAA) <ENTER>
or Press P, <ENTER> for print all.
    
```

3. Press 1 or 2 to specify the SLC loop, then the detector’s three digit address, then press the enter key; or to print a Detector Maintenance Report (Figure 6.8 on page 100): Press P; then, press the enter key.

### 6.5.3 View Detector Maintenance for a Detector

When you enter the detector SLC address the control panel displays the Detector Maintenance Status screen as shown below:



**Figure 6.7 Detector Maintenance Status Screen**

Once you display information for a detector, you can use the **+** (Next Selection) and **-** (Previous Selection) keys to view information for the next or previous detector on the SLC.

Refer to “Interpreting a Detector Status Display or Maintenance Report” on page 100 for descriptions of each item.

## 6.5.4 Print a Detector Maintenance Report

A Detector Maintenance Report lists detector maintenance status for each installed addressable detector [except FDX-551 (an analog heat detector)].

When you press and enter the **P** key the control panel sends a Detector Maintenance Report (Figure 6.8) to the printer connected to the control panel.

```

Detector Maintenance Report
↓
*** PRINT SMOKE DETECTOR MAINTENANCE ***
NORMAL SMOKE (PHOTO) INTENSIVE CARE UNIT Comp:032% Pk:0002% 000% AB B ** 1D043
NORMAL SMOKE (PHOTO) DETECTOR ADDR 1D044 Comp:027% Pk:0001% 000% AB B ** 1D044
NORMAL SMOKE (PHOTO) DETECTOR ADDR 1D045 Comp:028% Pk:0001% 000% AB B ** 1D045
NORMAL SMOKE (PHOTO) DETECTOR ADDR 1D046 Comp:030% Pk:0001% 000% AB B ** 1D046
NORMAL SMOKE (PHOTO) DETECTOR ADDR 1D047 Comp:024% Pk:0002% 000% AB B ** 1D047
NORMAL SMOKE (PHOTO) DETECTOR ADDR 1D048 Comp:031% Pk:0002% 000% AB B ** 1D048
NORMAL SMOKE (PHOTO) DETECTOR ADDR 1D049 Comp:033% Pk:0002% 000% AB B ** 1D049
NORMAL SMOKE (PHOTO) DETECTOR ADDR 1D050 Comp:008% Pk:0003% 000% AB B ** 1D050
***** PRINT END *****
*****

```

Figure 6.8 Sample Detector Maintenance Report

## 6.5.5 Interpreting a Detector Status Display or Maintenance Report

Detector Maintenance Status Screens and Detector Maintenance Reports provide the same information (such as Device Status, Compensation, Peak Value) about a detector. This section contains descriptions of each item that appears in a Detector Maintenance Status Screen or a Detector Maintenance Report.

```

NORMAL SMOKE (PHOTO) DETECTOR ADDR 1D044 Comp:027% Pk:0001% 000% AB B C * 1D044
1          2          3          4          5          6          7          8          9          10         11

```

1. **Device Status** (NORMAL) The status of the detector: NORMAL, ALARM, DISABL OR TEST.
2. **Type Code** (SMOKE (PHOTO)) The software Type Code that identifies the type of detector. Refer to “Type Codes for Intelligent Detectors” on page 108.
3. **Custom Label** (DETECTOR ADDR 1D044) The 19-character user-defined custom label.
4. **Drift Compensation** (COMP:027%) The relative cleanliness of a detector determined by sampling the amount of contaminants in the detector, ambient air conditions, and the age of the detector. The Comp value also indicates if a detector requires maintenance. Refer to “Maintenance Warnings – Three Levels” on page 92 for definitions of maintenance levels. The table below contains a list of the maintenance level values for each type of detector:

Type of Detector	Normal	Low Chamber Reading	Maint. Alert	Maint. Urgent
Ion	006-068	less than 006	92-99	100
Photo	006-069	less than 006	93-99	100
Laser	003-063	less than 003	83-99	100
Acclimate Plus™	n/a	LO-VAL	Dirty1	Dirty2

Table 6.3 Maintenance Levels by Detector Type

5. **Peak Value** (PK:0001%) The highest analog value reached by the detector during the past week. The peak value slowly returns to zero.

6. **Alarm Reading** (000%) The current alarm reading of the detector, as a percentage of the Alarm Sensitivity setting.
7. **Alarm Sensitivity Setting** (A8) The Alarm Sensitivity (x=1-9) entered in the Detector Sensitivity Screen.
8. **Pre-Alarm Sensitivity Setting** (8) The Pre-Alarm Sensitivity (1-9; 0 = Pre-Alarm not used) entered in the Detector Settings Screen. Refer to “Detector Sensitivity Settings” on page 97 for more information on the Pre-Alarm sensitivity settings.
9. **Multi-Detector Selection** (\*) A smoke detector programmed so that it evaluates readings from nearby detectors in making Alarm or Pre-Alarm decisions. Cooperative Multi-Detector sensing also allows the combination of ionization with photoelectric technology in reaching an alarm decision. See “Modify an Addressable Detector Point” on page 21 for instructions on setting Cooperative Multi-Detector Settings.
  - \* – Multi-not used.
  - A – combines the detector’s alarm decision with the next address above.
  - B – combines the detector’s alarm decision with the next address below.
  - C – combines the detector’s alarm decision with the next address above and the next address below.
10. **Alarm Verification** (\*)
  - \* – Alarm Verification not programmed for this detector.
  - V– Alarm Verification enabled.
  - xx – Alarm Verification programmed for the detector; xx equals the Verification Counter (00-99). See “Modify an Addressable Detector Point” on page 21 for instructions on setting Alarm Verification.
11. **Device SLC Address** (1D044) The SLC address of the detector.

# Appendix 7: CBE (Control-By-Event)

## 7.1 Description

CBE (Control-By-Event) is a software function that provides a means to program a variety of output responses based on various initiating events. The control panel operates Control-By-Event (CBE) through 99 Software Zones with the following features:

- Each input point (detector, monitor module) can list up to five Software Zones
- Each output point (control module or NAC) can list up to five Software Zones
- Output points can list zone Z00 (general alarm). Non-Alarm or Supervisory points do not activate Software Zone Z00 (general alarm)

## 7.2 Input and Outputs

Input and output devices with CBE-listed Software Zones work as follows:

These devices	Operate with CBE as follows
Inputs (detectors, monitor modules)	When an input device activates, so do all Software Zones listed to the input device.
Outputs (control modules and NACs)	When a Software Zone activates, the output device(s) in that zone turns on.

## 7.3 Equations

Space for up to twenty logic or time delay equations is included in the control panel. Each equation can be a logic equation or a time delay function. A time delay function can have a logic equation as an internal equation, but not vice versa. The rules of the equations are:

1. Equations can be entered, edited and viewed in the VeriFire™ Tools program, but can only be viewed on the control panel.
2. The twenty equations are designated in the panel as ZE0-ZE9 and ZL0-ZL9, and are evaluated in that order.



---

**NOTE:** In the VeriFire™ Tools program, ZL1 - ZL10 corresponds to ZE0-ZE9, and ZL11 - ZL20 corresponds to ZL0-ZL9.

---

3. Equations will always begin with a logic or a time delay function.
4. Equations will be a maximum of 73 characters long, including parentheses and commas.
5. Equations can have a maximum of 10 logic functions. The function set is listed below in “Equation Entry” on page 103.
6. These equations are to be evaluated after all other devices have been evaluated.
7. One logic equation can be used as a variable in another equation only if the equation used has previously been evaluated. For example, the results of the ZE0 equation can be used in the ZL5 equation but the opposite is not true.
8. Time delay equations can use any other functions as an internal equation, but the other function can not use time delay equation as an internal equation.
9. A logic instruction can have a maximum of 20 arguments (inclusive start and stop address).
10. Maximum for the delay timer is 18 hours 12 minutes.

## 7.4 Equation Entry

The equations must be entered using the VeriFire™ Tools Program Utility. All are subject to the maximum number of arguments possible in a logic instruction as discussed above (Item Number 9 on page 102).

### 7.4.1 Logic Functions

#### The “AND” Operator

Requires that each argument be in alarm.

Example: AND(Z02,Z05,Z09)

All three arguments in the equation must be in alarm for the output point to be activated.

#### The “OR” Operator

Requires that any argument be in alarm

Example: OR(Z02,Z05,Z09)

If any one of the three arguments in the equation is in alarm the output point will be activated.

#### The “NOT” Operator

Inverts the state of the argument (activated to deactivated OR deactivated to activated).

Example: NOT(Z02)

The output point will remain activated until the argument goes into alarm.

If the argument goes into alarm the output point will deactivate.

#### The “ONLY1” Operator

Requires that only one argument be in alarm.

Example: ONLY1(Z02,Z05,Z09)

If only one of the arguments is in alarm the output point will be activated.

#### The “ANY2” Operator

Requires that two or more arguments be in alarm.

Example: ANY2(Z02,Z05,Z09)

If any two or more of the arguments are in alarm the output point will be activated.

#### The “ANY3” Operator

Requires that three or more arguments be in alarm.

Example: ANY3(Z02,Z05,Z07,Z09)

If any three or more of the arguments are in alarm the output point will be activated.

#### The “XZONE” Operator

Requires that any combination of two or more input devices programmed to a zone be in alarm.

Example: XZONE(Z02)

If any combination of two or more initiating devices that have been programmed (CBE) to this software zone comes into alarm, then this output point will be activated.

#### The “RANGE” Operator

Each argument within the range must conform to the requirements of the governing operator. The range limit is 20 consecutive arguments.



Example: AND(RANGE(Z1,Z20))

Zone 1 through Zone 20 must all be in alarm for the output point to be activated.

### 7.4.2 Equation Syntax Example

**OR(AND(L1D1,L1D4),AND(L2D6,L2M3,NOT(L2M4)),ANY2(L1M13,L1M14,L1M15))**

Equation begins with a logic or time delay function - OR

67 Characters (maximum of 73) - includes parentheses and commas.

5 Logic Functions (maximum of 10) - OR, AND, AND, NOT and ANY2.

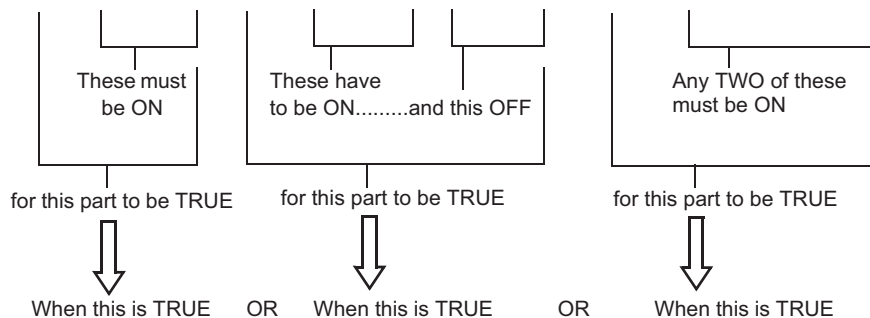
8 Arguments (maximum of 20 per logic function) - L1D1,L1D4,L2D6,L2M3,L2M4....

The equation contains no spaces.

### 7.4.3 Evaluating an Equation

When you evaluate an equation, you start from the innermost part of the equation and work outwards. For this equation to evaluate TRUE and thus turn on any output mapped to it, the following conditions must be met:

OR(AND(L1D1,L1D4),AND(L2D6,L2M3,NOT(L2M4)),ANY2(L1M13,L1M14,L1M15))



Then all outputs programmed with this equation will be turned ON.

### 7.4.4 Argument Entries

The argument entries of the logic functions can be another logic function or any of the devices listed below:

1D1 – 1D159	detectors loop 1	(159)
1M1 – 1M159	modules loop 1	(159)
2D1 – 2D159	detectors loop 2	(159)
2M1 – 2M159	modules loop 2	(159)
B1 – B4	panel bells	(4)
Z0 – Z99	zones	(100)
F0 – F9	special function zones	(10)
R0 – R9	releasing zones	(10)
ZE0 – ZE9**	equations 0-9	(10)
ZL0 – ZL9***	equations 10-19	(10)

\*Node numbers can be entered in VeriFire for network programming.

\*\*Corresponds in VeriFire™ Tools to ZL1-ZL10

\*\*\*Corresponds in VeriFire™ Tools to ZL11-ZL20

Equations must be evaluated before use in another equation.

## 7.4.5 Time Delay Functions

### The “DEL” Operator

Used for delayed operation

Example: DEL(HH:MM:SS,HH:MM:SS,ZE5)

- The first HH:MM:SS is the delay time, the second HH:MM:SS is the duration time.
- If delay of zero is entered (00.00.00), the equation will evaluate true as soon as the internal equation (ZE5) evaluates true and will remain that way for the specified duration, unless the internal equation becomes false.
- If no duration is specified, then the device will not be deactivated until a reset occurs or the internal equation evaluates false.

### The “SDEL” Operator

A latched version of the DEL operator. Once the equation evaluates true, it remains activated until a reset, even if the internal equation (ZE5) becomes false.

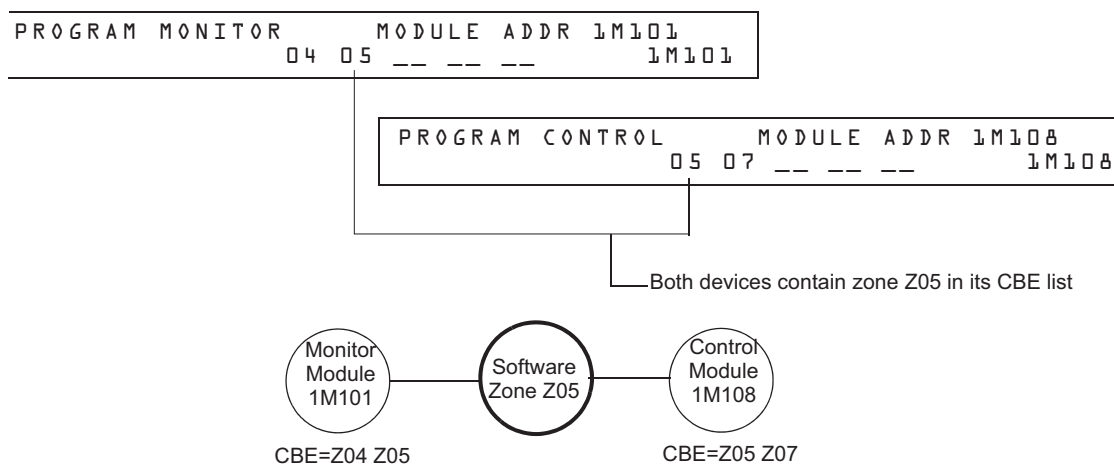
Example: SDEL(HH:MM:SS,HH:MM:SS,ZE5)

- The first HH:MM:SS is the delay time, the second HH:MM:SS is the duration time.
- If delay of zero is entered (00.00.00), the equation will evaluate true as soon as the internal equation (ZE5) evaluates true and will remain that way for the specified duration.
- If no duration is specified, then the device will not deactivate until reset.

The installer can enter the equations in any combination wanted as long as the format of the logic function or time delay is followed from the lists above. Error checking will be performed after the user has entered the complete equation. Possible errors are too many or too few parentheses, too many or too few arguments inside the parentheses, unknown function and unknown device type.

## 7.5 CBE Example

An example of CBE, where monitor module 1M101 lists zone Z04 and Z05, and control module 1M108 lists zone Z05 and zone Z07:



**Figure 7.1 CBE Example**

When monitor module 1M101 activates, the following CBE takes place:

1. Software Zones Z04 and Z05 activate.
2. Since control module 1M108 has Z05 in its CBE list, all of its outputs would activate. All output devices with Z04 or Z05 would activate.

# Appendix 8: Detector Initialization

## 8.1 Overview

The control panel automatically performs a detector initialization routine when you add or change a detector, unless the control panel is in Walk Test or Advanced Walk Test. If you change a detector with the control panel in Walk Test or Advanced Walk Test, you must manually initialize the detector as detailed in “How to Manually Initialize a Detector” on page 107. The detector initialization routine takes approximately 2.5 minutes, during which time the FACP remains in service. While initializing a detector, follow these guidelines:

- Make sure the detector is free of residual smoke during detector initialization.
- Do not test a detector during detector initialization.



---

**NOTE:** The control panel only performs detector initialization if it senses that a detector was removed for at least 15 seconds. This is what actually “turns on” the detector. It is an automatic procedure but is specified here because of the delay between detector connection and full function. The rest of the system remains in full service during this time.

---

A sample screen that appears on the LCD display during detector initialization.

```
Detector Initializing _ Please Wait  
02:48P 041508 Sat
```



**WARNING:**

If you replace any detector with a different type of detector (for example, replace a laser detector with a photoelectric detector), you must immediately program the control panel with the new detector Type Code. Failure to do so can cause incorrect control panel operation, including false alarms. For instructions on replacing a detector, refer to “How to Replace a Detector” on page 106.

---

## 8.2 System Testing and Detector Initialization

To facilitate system testing, the control panel does not initialize detectors during Walk Test and Advanced Walk Test. You can remove a detector to confirm supervision, then replace the detector for immediate testing. If you replace a removed detector with a different detector of the same type, you must manually initialize the detector according to the instructions in “How to Manually Initialize a Detector” on page 107. If, however, you want to replace a removed detector with a different type of detector, refer to “How to Replace a Detector” on page 106.

## 8.3 How to Replace a Detector

If you replace a detector with a different type of detector, you must immediately program the control panel for the new detector type. To replace a detector, follow these steps:



---

**NOTE:** Parentheses show an example of replacing an existing photoelectric detector at address 1D101 with a laser detector.

---

Step	Action
1	Disable the point of the detector. (point 1D101)
2	Remove the photoelectric detector and replace with laser detector set to the same address.
3	Autoprogram the panel to recognize the new detector type.
4	Enable new detector.

## 8.4 How to Manually Initialize a Detector

You only need to manually initialize a detector when you change a detector during Walk Test or Advanced Walk Test. If, however, you replace a detector with a different type of detector, you must immediately program the new detector according to the instructions in “How to Replace a Detector” on page 106.

To manually initialize a detector, follow these steps:

1. Press the ENTER key. The control panel displays the Program Entry screen:

```
1=PROGRAMMING          2=READ STATUS ENTRY
(ESCAPE TO ABORT)
```

2. Press the 1 key. The control panel displays the Enter Password screen:

```
ENTER PROG OR STAT PASSWORD, THEN ENTER.
(ESCAPE TO ABORT)
```

3. Enter the password RESET, which starts detector initialization. The control panel displays the following three screens, in the sequence shown, while initializing a detector:

```
CHECKING MEMORY NFS2-640 Release 1.0
Software #XXXXXXX
```

```
Detector Initializing _ Please Wait
02:48P 041508 Tue
```

When the control panel completes the detector initialization, it displays system status as shown below:

```
SYSTEM NORMAL          02:50P 041508 Tue
```

# Appendix 9: Type Codes

## 9.1 What are Type Codes?

Type Codes are software selections for initiating devices (detectors and monitor modules) and output devices (control modules and NACs). Some Type Codes are self-explanatory; that is, the Type Code matches the function of the device, such as a “Monitor” for a monitor module, “Photo” for a photoelectric detector, and so on. Type codes also provide special functions, such as activating switches, solenoids, and control panel functions.

## 9.2 How to Select a Type Code

You select a Type Code through the Point Programming screen. For instructions, refer to “Modify or Delete a Point (2=point)” on page 20.

## 9.3 In this Appendix

This appendix contains detailed descriptions of Type Codes for input and output devices, as listed below:

Type of Device	Refer to page
9.4.2, "Type Codes for Intelligent Detectors"	page 108
9.4.3, "Type Codes for Monitor Modules"	page 110
9.5.2, "Type Codes for Control Modules"	page 112
9.5.3, "NAC Type Codes"	page 112

## 9.4 Type Codes for Input Devices

### 9.4.1 Overview

This section provides Type Codes for intelligent detectors and monitor modules. For instructions on programming Type Codes, refer to “Modify or Delete a Point (2=point)” on page 20.

### 9.4.2 Type Codes for Intelligent Detectors

A list of intelligent detector Type Codes, which specify the type of detector installed at an SLC address.

Type Code	Point Type	Point Characteristics		Device Function
		Latching (Y/N)	Point Function	
SMOKE (ION)	fire alarm	Y	lights fire alarm LED and activates CBE	ionization smoke detector
SMOKE(DUCTI)	fire alarm	Y	lights fire alarm LED and activates CBE	Duct ionization smoke detector
SUP.T(DUCTI) <sup>3</sup>	supervisory	N	lights supervisory LED	ionization smoke detector used as a duct detector to report supervisory condition rather than alarm. Tracking.
SUP.L(DUCTI)	supervisory	Y	lights supervisory LED	ionization smoke detector used as a duct detector to report supervisory condition rather than alarm. Latching.
SUP.T(ION) <sup>2,3</sup>	supervisory	N	lights supervisory LED	ionization smoke detector used to report supervisory condition rather than alarm. Tracking.
SUP.L(ION) <sup>2</sup>	supervisory	Y	lights supervisory LED	ionization smoke detector used to report supervisory condition rather than alarm. Latching.

**Table 9.1 Intelligent Detector Type Codes (1 of 2)**

SMOKE(PHOTO)	fire alarm	Y	lights fire alarm LED and activates CBE	Photoelectric smoke detector
SMOKE(DUCTP)	fire alarm	Y	lights fire alarm LED and activates CBE	Duct Photoelectric smoke detector
SUP.T(DUCTP) <sup>3</sup>	supervisory	N	lights supervisory LED	Photoelectric smoke detector used as a duct detector to report supervisory condition rather than alarm. Tracking.
SUP.L(DUCTP)	supervisory	Y	lights supervisory LED	Photoelectric smoke detector used as a duct detector to report supervisory condition rather than alarm. Latching.
SUP.T(PHOTO) <sup>2,3</sup>	supervisory	N	lights supervisory LED	Photoelectric smoke detector used to report supervisory condition rather than alarm. Tracking.
SUP.L(PHOTO) <sup>2</sup>	supervisory	Y	lights supervisory LED	Photoelectric smoke detector used to report supervisory condition rather than alarm. Latching.
RF_PHOTO	fire alarm	Y	lights fire alarm LED and activates CBE	Wireless Photoelectric smoke detector
SMOKE(HARSH) <sup>1</sup>	fire alarm	Y	lights fire alarm LED and activates CBE	HARSH smoke detector
SMOKE(BEAM)	fire alarm	Y	lights fire alarm LED and activates CBE	Beam smoke detector
SMOKE(LASER)	fire alarm	Y	lights fire alarm LED and activates CBE	Laser smoke detector
SUP.L(LASER) <sup>2</sup>	supervisory	Y	lights supervisory LED	Laser smoke detector used to report supervisory condition rather than alarm. Latching.
SUP.T(LASER) <sup>2,3</sup>	supervisory	N	lights supervisory LED	Laser smoke detector used to report supervisory condition rather than alarm. Tracking.
SMOKE(DUCTL)	fire alarm	Y	lights fire alarm LED and activates CBE	Duct Laser smoke detector
SUP T(DUCTL)	supervisory	N	lights supervisory LED	Laser smoke detector used as a duct detector to report supervisory condition rather than alarm. Tracking.
SUP L(DUCTL)	supervisory	Y	lights supervisory LED	Laser smoke detector used as a duct detector to report supervisory condition rather than alarm. Latching.
AIR REF	fire alarm	Y	lights fire alarm LED and activates CBE	Assign to one or more FSL-751 detectors used to monitor the quality of air entering the protected area. The air quality measurement allows the VIEW <sup>®</sup> system to compensate for vehicle fumes, fog, or other particles brought into the protected area through the ventilation system. Poor air quality will lower the sensitivity of all FSL-751 detectors on the SLC. The detector sensitivity, however, remains within approved limits (always less than 1% obscuration per foot).
<b>NOTE:</b> A reference detector still functions as a smoke detector, but you should set the detector sensitivity level to the least sensitive level—AL:9 and PA:9 Change Alarm and Pre-Alarm sensitivity. Refer to “Detector Sensitivity Settings” on page 97 for a complete list of detector sensitivity settings.				
HEAT	fire alarm	Y	lights fire alarm LED and activates CBE	190°F intelligent thermal sensor
HEAT+	fire alarm	Y	lights fire alarm LED and activates CBE	190°F intelligent thermal sensor with low temperature warning.
HEAT(FIXED)	fire alarm	Y	lights fire alarm LED and activates CBE	135°F intelligent thermal sensor
HEAT (ROR)	fire alarm	Y	lights fire alarm LED and activates CBE	15°F per minute rate-of-rise detector
SMOKE ACCLIM	fire alarm	Y	lights fire alarm LED and activates CBE	Combination Photoelectric/heat detector without freeze warning (Acclimate Plus™)
SMOKE(ACCLI+)	fire alarm	Y	lights fire alarm LED and activates CBE	Combination Photoelectric/heat detector with freeze warning (Acclimate Plus™, or IntelliQuad FSC-851 Photoelectric Multi-Criteria Smoke Sensor)
SMOKE(MULTI) <sup>1</sup>	fire alarm	Y	lights fire alarm LED and activates CBE	Multisensor smoke detector
<sup>1</sup> CLIP Mode only				
<sup>2</sup> Requires approval of AHJ.				
<sup>3</sup> Not suitable for Canadian applications.				

Table 9.1 Intelligent Detector Type Codes (2 of 2)

### 9.4.3 Type Codes for Monitor Modules

A list of monitor module Type Codes, which you can use to change the function of a monitor module point.

Type Code	Point Type	Point Characteristics		Device Function
		Latching (Y/N)	Point Function	
MONITOR	fire alarm	Y	Lights fire alarm LED and activates CBE	Alarm-monitoring device
PULL STATION	fire alarm	Y	Lights fire alarm LED and activates CBE	Manual fire-alarm-activating device, such as a pull station
RF MON MODUL	fire alarm	Y	Lights fire alarm LED and activates CBE	Wireless alarm-monitoring device
RF PULL STA	fire alarm	Y	Lights fire alarm LED and activates CBE	Wireless manual fire-alarm-activating device, such as a pull station
SMOKE CONVEN	fire alarm	Y	Lights fire alarm LED and activates CBE	Indicates activation of a conventional smoke detector attached to an FZM-1
SMOKE DETECT	fire alarm	Y	Lights fire alarm LED and activates CBE	Indicates activation of a conventional smoke detector attached to an FZM-1
WATERFLOW	fire alarm	Y	Lights fire alarm LED and activates CBE	Monitor for waterflow alarm switch
WATERFLOW S	supervisory	Y	Lights supervisory LED and activates CBE	Indicates supervisory condition for activated waterflow switch
ACCESS MONTR	non-alarm	N	Activates CBE	Used for monitoring building access
AREA MONITOR	security	Y	Lights security LED and activates CBE	Monitors building access
AUDIO SYSTEM	trouble	N	Lights trouble LED	Used for monitoring audio equipment
EQUIP MONITR	security	N	Activates CBE	Used for recording access to monitored equipment
RF SUPERVSRY	supervisory	N	Lights Supervisory LED	Monitors a radio frequency device
SECURITY	security	Y	Lights security LED	Indicates activation of security alarm
LATCH SUPERV	supervisory	Y	Lights supervisory LED	Indicates latching supervisory condition
TRACK SUPERV	supervisory	N	Lights supervisory LED	Monitors for waterflow tamper switches for alarm points
SYS MONITOR	security	Y	Lights security LED and activates CBE	Monitors equipment security
TAMPER	supervisory	Y	Lights supervisory LED, activates CBE	Indicates activation of tamper switch
ACK SWITCH	non-alarm	N	Performs Acknowledge function, no CBE	Silences panel sounder, gives an Acknowledge message on the panel LCD
ALLCALL PAGE	non-alarm	N	Activates all speaker circuits, no CBE	Performs AMG-1 All-call
DRILL SWITCH	non-alarm	N	Performs Drill function	Activates silenceable outputs
EVACUATE SWITCH	non-alarm	N	Performs Drill function	Activates all silenceable outputs
FIRE CONTROL	non-alarm	Y	Activates CBE	Used for non-fire activation of outputs
NON FIRE	non-alarm	N	Activates CBE	Used for building energy management
PAS INHIBIT	non-alarm	N	Inhibits Positive Alarm Sequence	Inhibits Positive Alarm Sequence
POWER MONITR	trouble	N	Indicates trouble	Monitors auxiliary power supplies
RESET SWITCH	non-alarm	N	Performs Reset function	Resets control panel
SIL SWITCH	non alarm	N	Performs Signal Silence function	Turns off all activated silenceable outputs
TELE PAGE	non-alarm	N	Performs function of Page Button on FFT-7	Allows remote paging to a fire area
DISABLE MON	disable	N	When a point with this type code activates, it will create a disable on the panel for that point. No CBE generated.	Module can not be disabled via ACS, Alter Status, or over the network.
TROUBLE MON	trouble	N	Indicates Trouble	Monitors trouble inputs
ABORT SWITCH	non alarm	N	Indicates Active at the panel	Aborts activation of a releasing zone
MAN RELEASE	fire alarm	Y	Lights Fire Alarm LED and activates CBE	Indicates activation of a monitor module programmed to releasing zone to perform a releasing function
MANREL DELAY	fire alarm	Y	Lights Fire Alarm LED and activates CBE	Indicates activation of a monitor module programmed for a release output
SECOND SHOT	fire alarm	Y	Indicates Active at the panel and activates CBE	Provides second activation of releasing zone after soak timer has expired.
Blank	fire alarm	Y	Lights fire alarm LED and activates CBE	Monitors for a device with no description
HEAT DETECT	fire alarm	Y	Lights fire alarm LED and activates CBE	Monitors for conventional heat detector

**Table 9.2 Type Codes for Monitor Modules**

## **9.5 Type Codes for Output Devices**

### **9.5.1 Overview**

This section provides Type Codes for control modules and NACs. For instructions on programming Type Codes, refer to “Modify or Delete a Point (2=point)” on page 20.



## 9.5.2 Type Codes for Control Modules

A comprehensive list of control module Type Codes, which you can select to change the function of an control module point.

Type Code	Silenceable (Y/N)	Configuration	Device Function
CONTROL	Y	NAC	Supervised NAC for notification appliance
RELAY	Y	Form-C relay	Relay output
BELL CIRCUIT	Y	NAC	Supervised NAC for notification appliance
STROBE CKT	Y	NAC	Supervised NAC for notification appliance
HORN CIRCUIT	Y	NAC	Supervised NAC for notification appliance
AUDIBLE CKT	Y	NAC	Supervised NAC for notification appliance
SPEAKER	Y	NAC	Supervised NAC for notification appliance
ISOLATED NAC	Y	NAC	Supervised NAC for notification appliance, used with audio isolators. Activates even if there is a short on its NAC circuit. For ULC installations only.
ISOLATED SPK	Y	NAC	Supervised NAC for speaker circuits, used with audio isolators. Activates even if there is a short on its audio circuit. For ULC installations only.
REL END BELL	N	NAC	Supervised NAC for notification appliance
blank	Y	NAC	Supervised NAC (for use when no other Type Code applies)
REL CKT ULC*	N	NAC	Releasing Circuit, power-limited, supervised for opens, shorts and ground faults (always non-silenceable)
RELEASE CKT*	N	NAC	Releasing circuit, nonpower-limited, supervised for opens and ground faults
RELEA.FORM C*	N	Form-C Relay	Relay output, contacts operate upon release
REL AUDIBLE	Y	NAC	NAC, activated upon release
NONRESET CTL	N	Form-C Relay and NAC	Relay output, unaffected by "System Reset" command
TELEPHONE	N	NAC	Standard Telephone circuit
INSTANT RELE*	N	NAC	NAC, short = normal; supervised for open circuits and ground faults. Always non-silenceable and switch-inhibited.
ALARMS PEND.	N	NAC	Output that will activate upon receipt of an alarm condition, and remain in the alarm state until all alarms have been acknowledged. It is programmed as "switch inhibit".
CONTROL NAC	Y	NAC	Supervised NAC
GEN ALARM	N	NAC	Control Module, an XPC-8 circuit, or an XP5-C (in NAC mode) configured as a Municipal Box Transmitter for NFPA 72 Auxiliary Fire Alarm Systems applications. This Type ID can also be used for general alarm activation. It is programmed as "switch inhibit".
GEN SUPERVIS	N	NAC	Control Module, an XPR-8 relay, or an XP5-C (in relay mode) activated under any Supervisory condition (includes sprinkler type). It is programmed as "switch inhibit".
GEN TROUBLE	N	NAC	Control Module, an XPR-8 relay, or an XP5-C (in relay mode) activated under any System Trouble condition. It is programmed as "switch inhibit".
GENERAL PEND	N	NAC	Control Module, an XPC-8 circuit, or an XP5-C (in NAC mode) that will activate upon receipt of an alarm and/or trouble condition, and remain in the ON state until all events have been ACKNOWLEDGED.
TROUBLE PEND	N	NAC	Control Module, an XPC-8 circuit, or an XP5-C (in NAC mode) that will activate upon receipt of a trouble condition, and remain in the ON state until all troubles have been ACKNOWLEDGED. It is programmed as "switch inhibit".

**Table 9.3 Control Module Type Codes**

\* The FCM-1-REL checks for shorts with all releasing type codes.

## 9.5.3 NAC Type Codes

A comprehensive list of Type Codes for panel NACs. For instructions on programming Type Codes, refer to "Modify or Delete a Point (2=point)" on page 20.

Type Code	Silenceable (Y/N)	Device Function
CONTROL	Y	Supervised NAC
BELL CIRCUIT	Y	Supervised NAC for notification appliance
STROBE CKT	Y	Supervised NAC for notification appliance
HORN CIRCUIT	Y	Supervised NAC for notification appliance
AUDIBLE CKT	Y	Supervised NAC for notification appliance

**Table 9.4 NAC Type Codes**

SPEAKER	N	Supervised NAC for speaker circuits
REL END BELL	N	Supervised NAC
blank label	Y	Supervised NAC for undefined device
REL CKT ULC	N	Releasing Circuit, power-limited, supervised for opens, shorts and ground faults (always non-silenceable)
RELEASE CKT	N	Releasing circuit, nonpower-limited, supervised for opens and ground faults
REL AUDIBLE	Y	NAC, activated upon release
REL CODE BELL	Y	Supervised NAC (NFS2-640 NAC only)
INSTANT RELE	N	NAC, short = normal; supervised for open circuits and ground faults. Always non-silenceable and switch-inhibited.
ALARMS PEND	N	Output that will activate upon receipt of an alarm condition, and remain in the alarm state until all alarms have been acknowledged. It is programmed as "switch inhibit".
CONTROL NAC	Y	Supervised NAC
GEN ALARM	N	Control Module, an XPC-8 circuit, or an XP5-C (in NAC mode) configured as a Municipal Box Transmitter for NFPA 72-2002 Auxiliary Fire Alarm Systems applications (MBT-1 required). This Type ID can also be used for general alarm activation. It is programmed as "switch inhibit".
GEN SUPERVIS	N	Control Module, an XPR-8 relay, or an XP5-C (in relay mode) activated under any Supervisory condition (includes sprinkler type). It is programmed as "switch inhibit".
GEN TROUBLE	N	Control Module, an XPR-8 relay, or an XP5-C (in relay mode) activated under any System Trouble condition. It is programmed as "switch inhibit".
GENERAL PEND	N	Control Module, an XPC-8 circuit, or an XP5-C (in NAC mode) that will activate upon receipt of an alarm and/or trouble condition, and remain in the ON state until all events have been ACKNOWLEDGED.
TROUBLE PEND	N	Control Module, an XPC-8 circuit, or an XP5-C (in NAC mode) that will activate upon receipt of a trouble condition, and remain in the ON state until all troubles have been ACKNOWLEDGED. It is programmed as "switch inhibit".

Table 9.4 NAC Type Codes



## Appendix 10: Region Settings

The REGION panel programming selection provides a setting for China. (Refer to “The Utility Program” on page 42.) This selection activates the following features:

- POM-8A support
- Active output events displayed. A counter is displayed for active outputs.
- Municipal communication panel settings
- New special function zone for alarm verification
- Prealarm automatically cleared after five minutes
- Co-op detectors alarm functions
- Dual alarm window
- Points in trouble will not activate
- Ten minute limit for DEL and SDEL delay functions
- Disable events do not light LED or trip the trouble relay
- no system trouble generated upon entering program mode
- Low AC operation of FACP
- Power supply troubles

## Notes

# Index

## A

- Abort Switch **29, 30, 55**
  - basic configuration example **58**
  - configuration example with monitor module **69**
  - Definition **57**
  - how it works **57**
  - to program **57, 69**
  - Type Code (ULI,IRI,NYC, or AHJ) **55**
- AC delay enable **32**
- Acclimate, detector sensitivity settings **97**
- ACS Annunciation, releasing applications **87**
- ACS annunciators
  - ACS Selection Groups A through O **35–41**
  - annunciation points **34**
  - annunciator display **34**
  - Selection Groups, global setting **32**
  - selection of display information **33**
- AHJ Abort Switch
  - example **64**
  - programming **63**
- Alarm
  - Alarm Verification Timer **32**
  - Scroll **43**
  - to select sensitivity **97**
- Alarm Verification Counters. See Detector headings. **50**
- Alarm Verification Timer **32**
- annunciation points **34**
- Argument **104**
- Auto Silence Timer **32**
- Autoprogram **15, 16–19**
  - default values **19**
  - to add/remove device **17**
  - to create a new program **16**
- Auxiliary Control Functions, releasing applications **87**

## B

- BACKUP option switch for NACs **55**
- Basic Program **14, 15–41**
- Baud rate
  - CRT Serial Port **45**
  - Printer Serial Port **44**
- Beam, detector sensitivity settings **97**
- Blink rate for SLC device LED **32**

## C

- California Code **29, 90**
- Canadian Two-Stage **29, 90**
- Caution

- Definition **9**
- Do not program detectors as CLIP... **44**
- Do not program more than 99 CLIP... **44**
- CBE (Control-By-Event) **102–105**
  - example **105**
- CBE list **21, 88, 89**
- Check option (program errors) **41**
- Clear memory **16**
- CLIP (Classic Loop Interface Protocol) **14, 44**
- Coding Function Selections **90**
- Coding, Special Zone F8 **19, 29, 31, 89**
- Control Module
  - to program **23**
- Cooperative Multi-Detector Sensing **94**
- Cross Zone **29, 30, 55**
  - programming example **66**
  - to activate a Releasing Zone **65**
  - Types **65, 66**
- Custom label **21**

## D

- DCC Mode **43**
- Default values, autoprogram **19**
- Delay Timer **29, 30, 55**
  - to program **56**
- Detector
  - Alarm Sensitivity Levels **93**
  - Initialization and System Testing **106**
  - Pre-Alarm Sensitivity Level **93**
  - Print a Detector Maintenance Report **100**
  - Program Values **21**
  - to Access Detector Maintenance Information **99**
  - to change sensitivity level **47, 49**
  - to clear alarm verification counters **47, 50**
  - to disable programmed points **47**
  - to manually initialize **107**
  - to program point **21**
  - to replace **106**
  - to Test Detectors Set Below 0.50% Obscuration per Foot **98**
- Detector Initialization **106–107**
- Device
  - to add **17**
  - to remove **18**
- Drift Compensation **91**
  - graphic representation **92**

## E

- Equations
  - Argument Entries **104**
  - Evaluating **104**

- logic and time delay **102**
- Logic Functions **103**
- rules **102**
- Time Delay Functions **105**

**F**

- FCM-1-REL, 2 second delay **19, 30**
- FireVoice **40**
- FlashScan
  - Devices, SLC options **44**
  - Poll **14, 44**
- FSC-851, detector sensitivity settings **98**

**G**

- Gentex Strobes **29**
- Gentex Strobes, special zone **90**
- Global System Functions **15**
  - defaults **32**
  - to change **32**

**H**

- History
  - Clear History **47, 50**
- Holiday **19, 31**
- Holiday, special zone **29**

**I**

- Initiating Devices, releasing zone **87**
- Instant Release Circuit
  - control module configuration example **85**
  - to program **85**
- Intelligent Sensing Applications **91–101**
  - Drift Compensation **91**
  - Maintenance Warnings, 3 levels **92**
  - Smoothing **91**
- Ion FSI-751, detector sensitivity settings **97**
- IP ACCESS **20, 43**
- IRI Abort Switch
  - example **60**
  - to program **60**

**K**

- keypad **12**

**L**

- Labels **21**
  - note about spaces **21**
- Local Control **43**
- LocM operating mode **32**
- LocT operating mode **32**
- Logic Functions **103**

**M**

- Maintenance Levels by Detector Type **100**
- Maintenance Warnings **92**
- Manual Release Delay Switch
  - monitor module configuration example **72**
  - to program **71**
- Manual Release Switch
  - monitor module configuration example **70**
  - to program **70**
- Manually Initialization, detector **107**
- March Time **29, 90**
- Master Box trouble message **33**
- Monitor
  - default zones **23**
  - to disable programmed points **47**
  - to program monitor **22**

**N**

- NAC
  - to disable programmed points **47**
- NBG-12LRA **57, 69, 70, 71, 73**
- Network node **42**
  - As argument entry **104**
- Network Program **14, 42**
  - network node number range **42**
- NFPA Standards for Releasing Applications **56**
- NFS2-640 keypad **12**
- NYC Abort Switch
  - examples **62**
  - programming **61**

**O**

- Operating parameters, to change. See Status Change

**P**

- PAS Inhibit switch **88**
- Password
  - Program Change (high level) **13**
  - Status Change (low level) **13, 47**
  - to change **26**
  - to enter **13**
- Point, to disable/enable **48**
- Poll, see FlashScan™ Poll, CLIP Poll
- Pre-Alarm **95**
  - Action Functions **96**
  - Alert Level **95**
  - to select a level **96**
  - to select sensitivity **97**
- Pre-Alarm, special zone **19, 29, 31**
- Presignal Delay Timer/PAS **19, 29, 30, 88**
- Program Change **14–45**
- Program Errors, check for **41**

**R**

- REGION Setting **42**
- Regional Settings **115**
- Release Audible Circuit
  - control module configuration example **84**
  - to program **83**
- Release Circuit
  - control module configuration example **80**
  - to program **79**
- Release Code Bell Circuit
  - NAC configuration example **86**
  - to program **86**
- Release End Bell Circuit
  - control module configuration example **76**
- Release End Bell Circuit, to program **75**
- Release Form-C Circuit
  - control module configuration example **82**
  - to program **81**
- Releasing Zones (R0-R9) **15, 19, 28, 30, 55**
  - type codes for inputs/outputs **68**
- RemT operating mode **32**
- Resound **24, 26, 43**

**S**

- Second Shot Switch **73**
  - monitor module configuration example
- Self-Optimizing Pre-Alarm **93**
- Sensitivity level for detector **47, 49**
- Silence Inhibit Timer **32**
- Smoothing **91**
- Soak Timer **29, 30, 55**
  - to program (NFPA 16 applications only) **67**
- Special Function, See Special Zones
- Special Zone Outputs **88–90**
- Special Zones
  - F0-F9 **15, 28**
  - FA, FB **15, 28**
  - Special Zone F0, notes and restrictions **88**
- Status Change **47–54**
  - Options **47**
- Strobes, See System Sensor, Gentex, Wheelock
- Strobes, special zone
- Style 4 network setting **42**
- Style 4 SLC wiring, global setting **32**
- Style 6 SLC wiring, global setting **32**
- Style 7 network setting **42**
- System clock **47**
- System Message, custom **15, 19, 27**
- SYSTEM NORMAL message **19**
- System Sensor Strobes, special zone **29, 90**

**T**

- Temporal Code **29, 90**
- Terminal mode supervision enable **32**

- Threshold Ch.A/B **42**
- Time
  - to set time/date for system clock **47, 50**
  - USA or European **32**
- Time control, special zones **19, 29, 30, 89**
- Time Delay Functions **105**
- TM-4 **33, 89**
- Trouble reminder **43**
- Two-Stage **29**
- Two-Stage Canada code **90**
- Two-stage code **90**
- Type Code
  - for releasing zone inputs/outputs **68**
- Type Codes **108–112**
  - explanation **108**
  - for Control Modules **112**
  - for Intelligent Detectors **108**
  - for Monitor Modules **110**
  - for NACs **112**
  - to select **108**

**U**

- UDACT **33**
- ULC Release Circuit
  - control module configuration example **78**
  - to program **77**
- ULI Abort Switch
  - example **59**
  - to program **59**
- Utility Program **14, 42**

**V**

- VeriFire™ Tools **12, 102, 103**

**W**

- Walk Test **47**
  - Activation Indications **53**
  - Advanced **53**
  - Basic
    - audible **52**
    - silent **52**
    - trouble **52**
- WARNING
  - Definition **10**
  - Disabling a zone disables all input and output devices.... **48**
  - Do not rely on disable/enable....to lock out releasing devices. **48**
  - If you replace any detector with a different type... **106**
  - Physically disconnect all releasing devices ..... **51**
  - The IRI abort switch will only work if.... **60**
  - Walk Test mode can deactivate fire protec-



tion... **51**  
When used for CO2 releasing applications... **55**  
Warning Sounders, releasing applications **87**  
Wheelock Strobes **29**  
Wheelock Strobes, special zone **90**

## **Z**

### Zones

Custom label **15, 28**  
Software Zones 01-99 **19**  
to disable programmed points **47**  
Z00 general alarm **19, 24, 41, 90, 96, 102**

# Manufacturer Warranties and Limitation of Liability

**Manufacturer Warranties.** Subject to the limitations set forth herein, Manufacturer warrants that the Products manufactured by it in its Northford, Connecticut facility and sold by it to its authorized Distributors shall be free, under normal use and service, from defects in material and workmanship for a period of thirty six months (36) months from the date of manufacture (effective Jan. 1, 2009). The Products manufactured and sold by Manufacturer are date stamped at the time of production. Manufacturer does not warrant Products that are not manufactured by it in its Northford, Connecticut facility but assigns to its Distributor, to the extent possible, any warranty offered by the manufacturer of such product. This warranty shall be void if a Product is altered, serviced or repaired by anyone other than Manufacturer or its authorized Distributors. This warranty shall also be void if there is a failure to maintain the Products and the systems in which they operate in proper working conditions.

MANUFACTURER MAKES NO FURTHER WARRANTIES, AND DISCLAIMS ANY AND ALL OTHER WARRANTIES, EITHER EXPRESSED OR IMPLIED, WITH RESPECT TO THE PRODUCTS, TRADEMARKS, PROGRAMS AND SERVICES RENDERED BY MANUFACTURER INCLUDING WITHOUT LIMITATION, INFRINGEMENT, TITLE, MERCHANTABILITY, OR FITNESS FOR ANY PARTICULAR PURPOSE. MANUFACTURER SHALL NOT BE LIABLE FOR ANY PERSONAL INJURY OR DEATH WHICH MAY ARISE IN THE COURSE OF, OR AS A RESULT OF, PERSONAL, COMMERCIAL OR INDUSTRIAL USES OF ITS PRODUCTS.

This document constitutes the only warranty made by Manufacturer with respect to its products and replaces all previous warranties and is the only warranty made by Manufacturer. No increase or alteration, written or verbal, of the obligation of this warranty is authorized. Manufacturer does not represent that its products will prevent any loss by fire or otherwise.

**Warranty Claims.** Manufacturer shall replace or repair, at Manufacturer's discretion, each part returned by its authorized Distributor and acknowledged by Manufacturer to be defective, provided that such part shall have been returned to Manufacturer with all charges prepaid and the authorized Distributor has completed Manufacturer's Return Material Authorization form. The replacement part shall come from Manufacturer's stock and may be new or refurbished. THE FOREGOING IS DISTRIBUTOR'S SOLE AND EXCLUSIVE REMEDY IN THE EVENT OF A WARRANTY CLAIM.

Warr-HL-08-2009.fm



---

World Headquarters  
12 Clintonville Road  
Northford, CT 06472-1610 USA  
203-484-7161  
fax 203-484-7118

[www.notifier.com](http://www.notifier.com)

**ISO 9001**  
**CERTIFIED**  
ENGINEERING & MANUFACTURING  
QUALITY SYSTEMS