



STAND PIPE PAC.[™]

MODEL SSS-100 DESIGN, INSTALLATION, OPERATION, AND MAINTENANCE MANUAL

Serial Number _____

Date of Installation _____ Date of Commissioning _____

UNITED Fire Systems

Division of UNITED Fire Protection Corporation
1 Mark Road
Kenilworth, NJ USA 07033
908-688-0300
www.unitedfiresystems.net

Manual Part Number 10-540001-001
Revision 2.03
February 2016

(THIS SURFACE DELIBERATELY LEFT BLANK)

INDEX

Section	Description	Page
	INDEX	i
	List Of Figures	ii
	List Of Tables	ii
	Safety Information	iii
	Foreword	iv
	Limited Warranty	v
1.	GENERAL INFORMATION	
1.1	System Purpose	1
1.2	NYC Local Law 64 / NYC Building Code 3303.8.1	1
1.3	Functional Description	1
2.	DESIGN	
2.1	Determining Internal Volume of Standpipe	4
2.2	Determining Desired Fill Time	4
2.3	Determining Proper STANDPIPE-PAC™ To Use	5
2.4	Example 1	6
2.5	Example 2	7
2.6	Options	8
2.6.1	Additional Audible Signals	8
2.6.2	Off-Site Signaling Via Dialer	8
3.	INSTALLATION	
3.1	Unpacking	9
3.2	Location	9
3.3	Installation	
3.3.1	Mounting	10
3.3.2	Piping	11
3.3.3	Manual Air Release Bleed Valve	11
3.3.4	Electrical Installation	
3.3.4.1	Codes	12
3.3.4.2	Personnel	12
3.3.4.3	Power Wiring	12
3.3.4.4	Battery Wiring	13
3.3.4.5	Optional Signal Wiring	14
3.3.4.6	Optional Dialer Wiring	14
3.4	Commissioning	
3.4.1	Startup	15
3.4.2	Testing	16
3.4.3	Placing In Service	17
3.4.4	Troubleshooting	17

4.	OPERATION	
4.1	Indicators	19
4.2	Controls	19
4.3	Indications	
4.3.1	Normal Operation	20
4.3.2	Low Pressure In Standpipe	20
4.3.3	High Pressure in Standpipe	21
4.4	Procedures	
4.4.1	Normal Operation	22
4.4.2	To Silence Piezo Sounder	22
4.4.3	To Silence Signal Horn(s)	22
4.4.4	For Fire Department Use Of Fire Standpipe	22
4.4.5	To Refill Standpipe With Air Pressure After Fire Department Use	23
4.4.6	To Test Standpipe with Water Pressure	23
5.	MAINTENANCE	24
5.1	Maintenance Intervals	
5.1.1	Weekly	25
5.1.2	Monthly	25
5.1.3	Quarterly	26
	APPENDICES	
Appendix A	Instructions – EPS10 Pressure Switch	
Appendix B	Instructions – EPS40 Pressure Switch	
Appendix C	Instructions – Desiccant Dryer Service	
Appendix D	Manual – 411UDAC Fire Alarm Communicator	
Appendix E	Instructions – General Air Compressor	

LIST OF FIGURES

Figure No.	Description	Page
1	STANDPIPE-PAC™ Unit	2
2	Manual Air Release Bleed Valve	3
3	Estimating Standpipe Fill Time	5
4	Design Example 1	6
5	Design Example 2	7
6	Dimensions – STANDPIPE-PAC™ Unit	10
7	STANDPIPE-PAC™ Installation	11
8	Battery Wiring	13
9	Wiring Diagram – Notification Appliance Circuit	14

LIST OF TABLES

Table No.	Description	Page
1	Available STANDPIPE-PAC™ Units	4
2	Determining Internal Volume of Standpipe	4
3	Current Requirements – STANDPIPE-PAC™ Units	12

SAFETY INFORMATION

This manual contains safety information that is important to know and understand. This information is provided for the safety of installers, operators, and users of the UNITED Fire Systems **STANDPIPE-PAC™** equipment. Carefully read, understand, and follow instructions identified by these symbols.



The use of the word “DANGER” identifies an immediate hazard with a likelihood of death or serious personal injury if instructions, including recommended precautions, are not followed.



The use of the word “WARNING” identifies the presence of hazards or unsafe practices that could result in death, personal injury, or serious property damage if instructions, including recommended precautions, are not followed.



The use of the word “CAUTION” identifies possible hazards or unsafe practices that could result in personal injury or property damage if instructions, including recommended precautions, are not followed.



The use of the word “IMPORTANT” identifies special instructions, not related to hazards, that should be followed.

FOREWORD

This manual is written for those who install, operate and maintain UNITED Fire Systems **STANDPIPE-PAC™** standpipe supervisory systems. The manual contains installation, operation, and maintenance information for the system. This manual must be read thoroughly and completely understood before installation and operation of UNITED Fire Systems **STANDPIPE-PAC™** equipment. All appropriate safety standards as determined by local or national laws and regulations should be followed at all times. When handling, installing, or operating this equipment, personnel must employ safe engineering practices and observe all related local regulations, health, and safety procedures, and legal requirements for safety. Ensure that the equipment is depressurized and electrically isolated before carrying out any of the scheduled maintenance instructions specified in this manual.



WARNING

DO NOT install, operate, or maintain unit if damage has occurred during shipping, handling, or use. Contact UNITED Fire Systems immediately. Failure to do so could result in death, personal injury, or serious property damage.



CAUTION

Read all of the safety information in this manual before installing, operating, or maintaining this equipment. Use of the equipment in a manner not specified within this manual may impair the protection provided by this equipment and could result in serious injury or damage. Only competent personnel should perform installation, operation, and maintenance procedures.



IMPORTANT

UNITED Fire Systems assumes no responsibility for the installation, operation, or maintenance of any systems other than those addressed in this manual. The data contained in this manual is for information purposes only. UNITED Fire Systems believes this data to be accurate at the time of publication, but the data is published and presented without any guarantee or warranty whatsoever. UNITED Fire Systems disclaims any liability for any use that may be made of the data and information contained in this manual by any and all parties.



IMPORTANT

The UNITED Fire Systems **STANDPIPE-PAC™** standpipe supervisory system is a vital part of the fire protection of any facility where these units are installed. Life safety and property protection depends on continuing proper operation of the assembly. The owner of the **STANDPIPE-PAC™** is responsible for the condition of the assembly and its continued proper operation. UNITED Fire Systems strongly recommends that all owners of **STANDPIPE-PAC™** systems engage the services of qualified, trained fire protection professionals to design the system containing the assembly, and to install and maintain the assembly.

UNITED Fire Systems **STANDPIPE-PAC™** standpipe supervisory systems are to be installed, operated, and maintained by qualified, trained personnel in accordance with:

- This Installation, Operation, and Maintenance Manual P/N 10-540000-001 Revision 2.00.
- National Fire Protection Association No. 14, "Standard for the Installation of Standpipe and Hose Systems."
- National Fire Protection Association No. 25, "Standard for the Inspection, Testing, and Maintenance of Water-Based Fire Protection Systems."
- National Fire Protection Association No. 70, "National Electrical Code®".

Any questions on the information in this manual should be addressed to:

UNITED Fire Systems, Division of United Fire Protection Corporation
1 Mark Road, Kenilworth, NJ USA 07033
908-688-0300 www.unitedfiresystems.net

LIMITED WARRANTY STANDPIPE-PAC™

What Does This Warranty Cover?

This warranty covers all manufacturing defects in material and workmanship in your new **STANDPIPE-PAC™**.

How Long Does The Coverage Last?

This warranty lasts for ninety (90) days from the date of shipment to the original purchaser.

What Will UNITED Fire Systems Do?

UNITED Fire Systems will repair, replace, or refund the purchase price of, at its option, any defective **STANDPIPE-PAC™** at no charge.

What Does This Warranty Not Cover?

STANDPIPE-PAC™s that have NOT been commissioned by UNITED Fire Systems or a trained distributor are not covered under this warranty. If you modify, change, or alter your **STANDPIPE-PAC™** without instructions from UNITED Fire Systems, the **STANDPIPE-PAC™** is not covered. If you break tamper seals applied by UNITED Fire Systems, the sealed parts are not covered. Any problem that is caused by abuse, misuse, or an act of God (such as a flood) is not covered. Also, consequential and incidental damages are not recoverable under this warranty. Some states do not allow the exclusion or limitation of incidental or consequential damages, so the above limitation or exclusion may not apply to you.

How Do You Obtain Service?

In order to be eligible for service under this warranty, your **STANDPIPE-PAC™** must have been commissioned by UNITED Fire Systems or a trained distributor. You must return the warranty registration form within 5 days of installation. If something goes wrong with your **STANDPIPE-PAC™**, contact your trained distributor or:

UNITED Fire Systems, Division of UNITED Fire Protection Corporation
1 Mark Road, Kenilworth, NJ 07033 USA
Phone: 908-688-0300 Fax: 908-481-1131

UNITED Fire Systems will contact you within 24 hours to arrange for evaluation of your **STANDPIPE-PAC™**.

Is This Warranty Transferable?

If the **STANDPIPE-PAC™** is moved from one to another installation during the time period of warranty coverage, the **STANDPIPE-PAC™** must be re-commissioned by UNITED Fire Systems or your trained distributor to be eligible for continuing coverage. You must pay a quoted charge for this re-commissioning.

Is This The Entire Warranty?

This limited warranty is the entire warranty given by UNITED Fire Systems to the purchaser of a new **STANDPIPE-PAC™**. There are no other warranties expressed or implied, beyond those required by law.

How Do State and Federal Laws Apply?

This warranty gives you specific legal rights per Federal law. You may also have other rights which vary from state to state.

1. GENERAL INFORMATION

1.1. System Purpose. The United Fire Systems **STANDPIPE-PAC™** Model SSS-100 Standpipe Supervisory System is a fully assembled standpipe supervisory system, including compressor, switches, alarm, and control unit providing one complete zone of standpipe supervision in compliance with NYC Local Law 64 / NYC BC 3303.8.1. All components are mounted on a sturdy wooden backboard, suitable for hanging at a construction or demolition site.

1.2. NYC Local Law 64 / NYC Building Code 3303.8.1

NYC Local Law 64 / NYC Building Code 3303.8.1 was implemented in response to serious difficulties encountered by the NYC Fire Department when fire standpipes at construction and demolition sites were damaged, rendering the standpipes unsuitable for fire department use. The code requires that all fire standpipes in vacant buildings, buildings undergoing demolition, and required permanent or temporary standpipes in buildings under construction be equipped with a system to pressurize the standpipe at all times, which then would sense the pressure loss if a portion of the standpipe was damaged or completely removed. Detailed requirements for the system are specified in the code. **STANDPIPE-PAC™** has been designed to aid in compliance with the requirements in Section 4 of Local Law 64. **IMPORTANT:** Section 3 of Local Law 64 requires that an application to install an air pressurized alarm system be filed by a registered design professional, and a permit obtained by a master plumber or licensed master fire protection contractor. A licensed electrician shall obtain all required electrical permits. Install **STANDPIPE-PAC™** after application is made and accepted, and all permits received. To review Local Law 64 / BC 3303.8.1 in its entirety, go to: www.unitedfiresystems.net.

1.3. Functional Description.

See Figures 1 and 2. **STANDPIPE-PAC™** consists of the following:

- (1) Air compressor with automatic control switch. The air compressor compresses atmospheric air for pressurizing the standpipe. The automatic control switch starts the compressor when the pressure is below 13 PSIG, and stops the compressor when the pressure exceeds 18 PSIG.
- (2) Desiccant air dryer. The desiccant air dryer dries the compressed air before entry into the standpipe, as required by Local Law 64 / BC 3303.8.1
- (3) Low-limit pressure sensing switch. This switch senses when the pressure in the standpipe drops below 7 PSIG, as would happen if a standpipe valve was inadvertently opened, or a portion of the piping was inadvertently removed. This switch sends its signal to the control unit (8).
- (4) High-limit pressure sensing switch. This switch senses when the pressure in the standpipe exceeds 23 PSIG, as may happen if the automatic control switch on the air compressor (1) fails. This switch sends its signal to the control unit (8).
- (5) Pressure gage. The pressure gage indicates the approximate pressure in the system in PSIG.
- (6) Check valve. The check valve prevents entry of water into the **STANDPIPE-PAC™** when the Fire Department pumps water into the standpipe. This device is required by Local Law 64 / BC 3303.8.1.
- (7) Lockable shutoff valve. This valve permits maintenance on the **STANDPIPE-PAC™** without de-pressurizing the entire standpipe. This device is required by Local Law 64 / BC 3303.8.1, and per this law, shall be locked in the OPEN position.
- (8) Control unit with power supply, backup battery, silence switch, and automatic dialer. The control unit accepts the signals from the pressure sensing switches (4) and (5), and operates the signal horn (9). The silence switch allows the signal horn (9) to be silenced. The power supply is dedicated to the system as required by Local Law 64 / BC 3303.8.1, and provides for backup battery power for the control unit. This device also provides an automatic dialer for connection of telephone lines for off-site notification.
- (9) A signal horn. Additional signal horns may be connected so that signaling may be heard throughout the site.
- (10) A junction box for connection of 120 VAC, 60 Hz, single phase power for both the air compressor (1) and the control unit (8). Connection of 120VAC 60 Hz single phase in this box provides power for both the air compressor (1) and the control unit (10).
- (11) An outlet for connection of piping to the dry standpipe. 1/2" NPT pipe (provided by installer) is run from the outlet to a connection point on the standpipe.
- (12) A disconnect switch to remove power from the air compressor (1). This switch facilitates testing and maintenance of the system.
- (13) A test / service device. See instructions in this manual for use of this device.
- (14) A serial number nameplate.

UNITED FIRE SYSTEMS
 STANDPIPE-PAC™ MODEL SSS-100
 INSTALLATION, OPERATION, AND MAINTENANCE MANUAL
 REVISION 2.03
 P/N 10-540000-001

(15) A manual air release bleed valve for Fire Department use. This device is to be installed near the siamese connection feeding the standpipe. A cap and chain is provided to protect the outlet. An instruction nameplate is also provided. This nameplate is to be securely fastened near the valve.

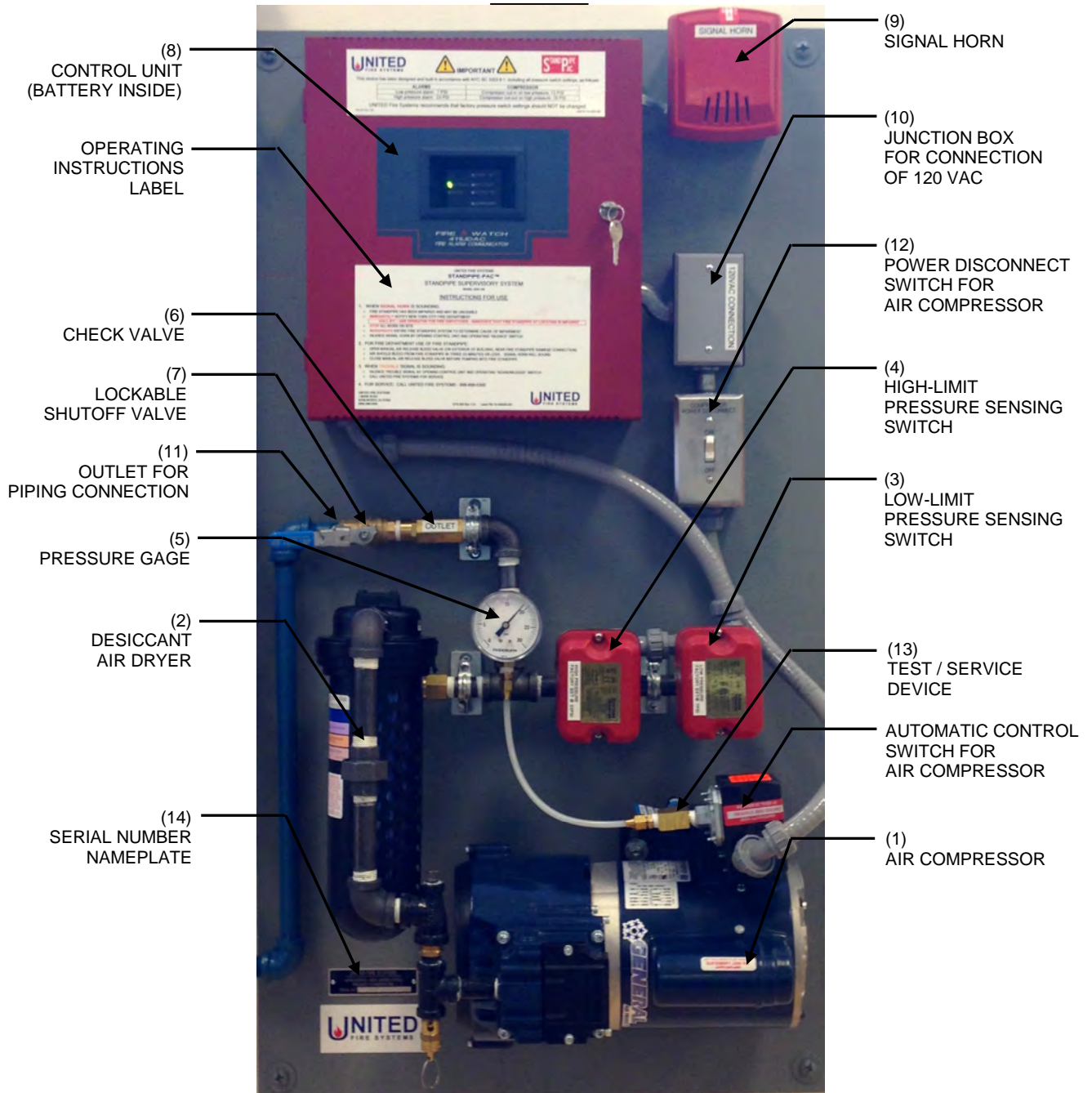

Figure 1 – STANDPIPE-PAC™ Unit

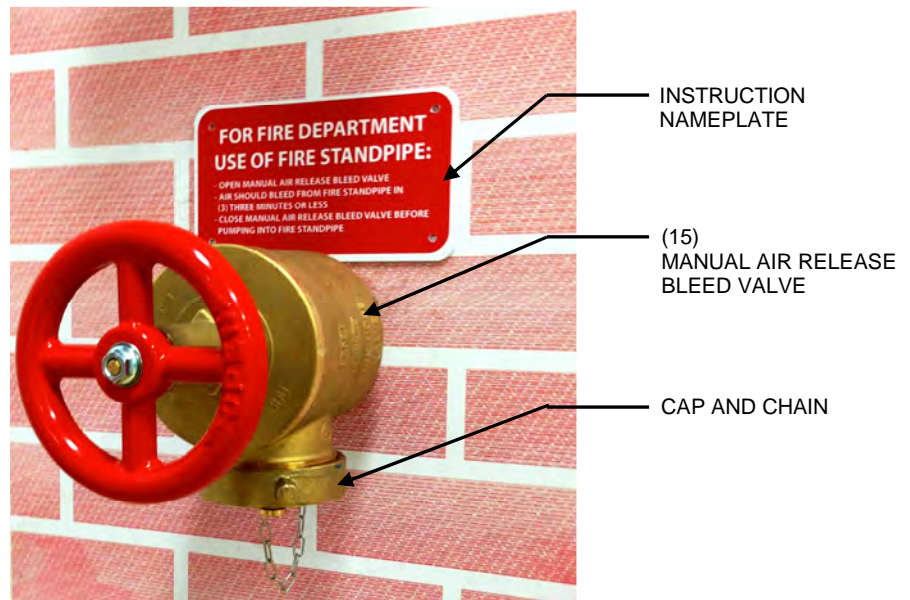

Figure 2 – Manual Air Release Bleed Valve

2. **DESIGN.** The specific **STANDPIPE-PAC™** to use is chosen based on the internal volume of the standpipe to be protected, and the desired fill time. See Table 1. Four (4) different units are available, based on compressor size.

STANDPIPE-PAC™ Part Number	Compressor Size, HP
SSS-100-16	1/6
SSS-100-13	1/3
SSS-100-12	1/2
SSS-100-34	3/4

Table 1 – Available **STANDPIPE-PAC™** Units

2.1. **Determining Internal Volume of Standpipe.** See Table 2. The internal volume of the standpipe, in gallons, is determined by multiplying the length of each pipe, by size, by the internal volume per foot, in gallons.

Nominal Pipe Size	Pipe Length in Feet		Gallons per Foot	Gallons
1-1/2"		X	0.106	
2"		X	0.174	
2-1/2"		X	0.248	
3"		X	0.383	
4"		X	0.660	
6"		X	1.500	
8"		X	2.600	
Other		X		
			TOTAL =	

Table 2 – Determining Internal Volume of Standpipe

2.2. **Determining Desired Fill Time.** Per Local Law 64 / BC3303.8.1, any impairment lasting 2 hours or more requires shutdown of the construction / demolition site and notification to the NYC Fire Department. The usual criterion is to fill / refill the standpipe in less than 2 hours, with margin for work performed for construction / demolition. NOTE: The NFPA 13 sprinkler system rule of 30 minutes "fast-fill" DOES NOT apply to standpipes.

2.3. Determining Proper STANDPIPE-PAC™ To Use. See Figure 3.

- 2.3.1. Find the desired fill time at the bottom of the graph.
- 2.3.2. Find the standpipe internal volume at the left of the graph.
- 2.3.3. Determine the intersection of the lines from these two values.
- 2.3.4. Choose the next-highest compressor horsepower.
- 2.3.5. Determine the P/N of the appropriate **STANDPIPE-PAC™** from Table 1.

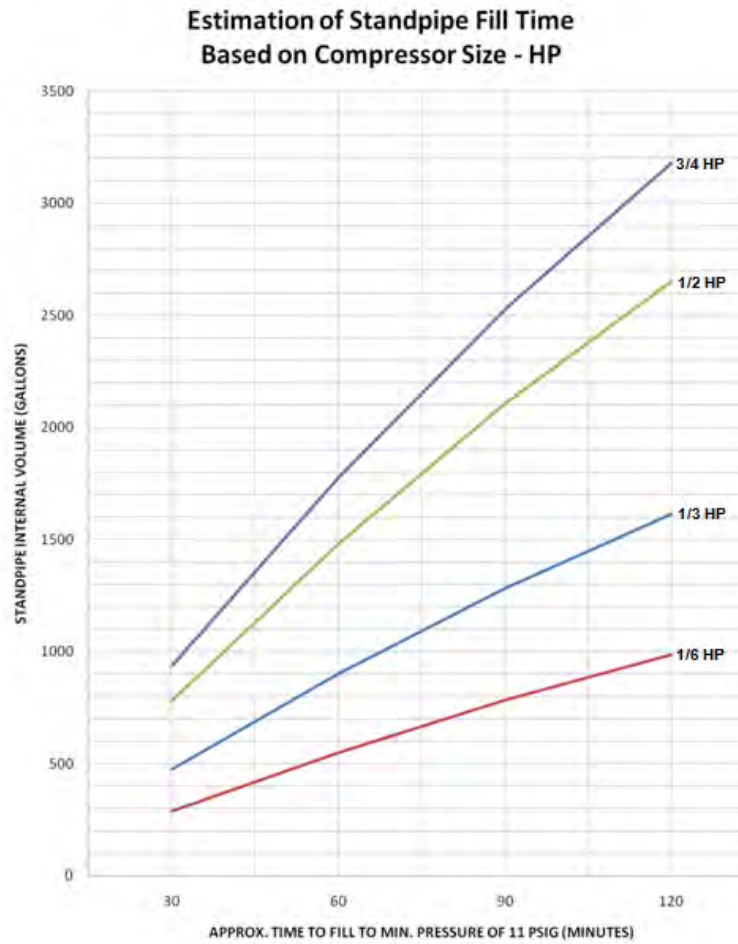

Figure 3 – Estimating Standpipe Fill Time

2.4. Example 1.

Nominal Pipe Size	Pipe Length in Feet		Gallons per Foot	Gallons
6"	850	X	1.500	1275
			TOTAL =	1275 gallons

Required work can be performed in 1/2 hour (30 minutes), so a fill time of 1-1/2 hours (90 minutes) is satisfactory

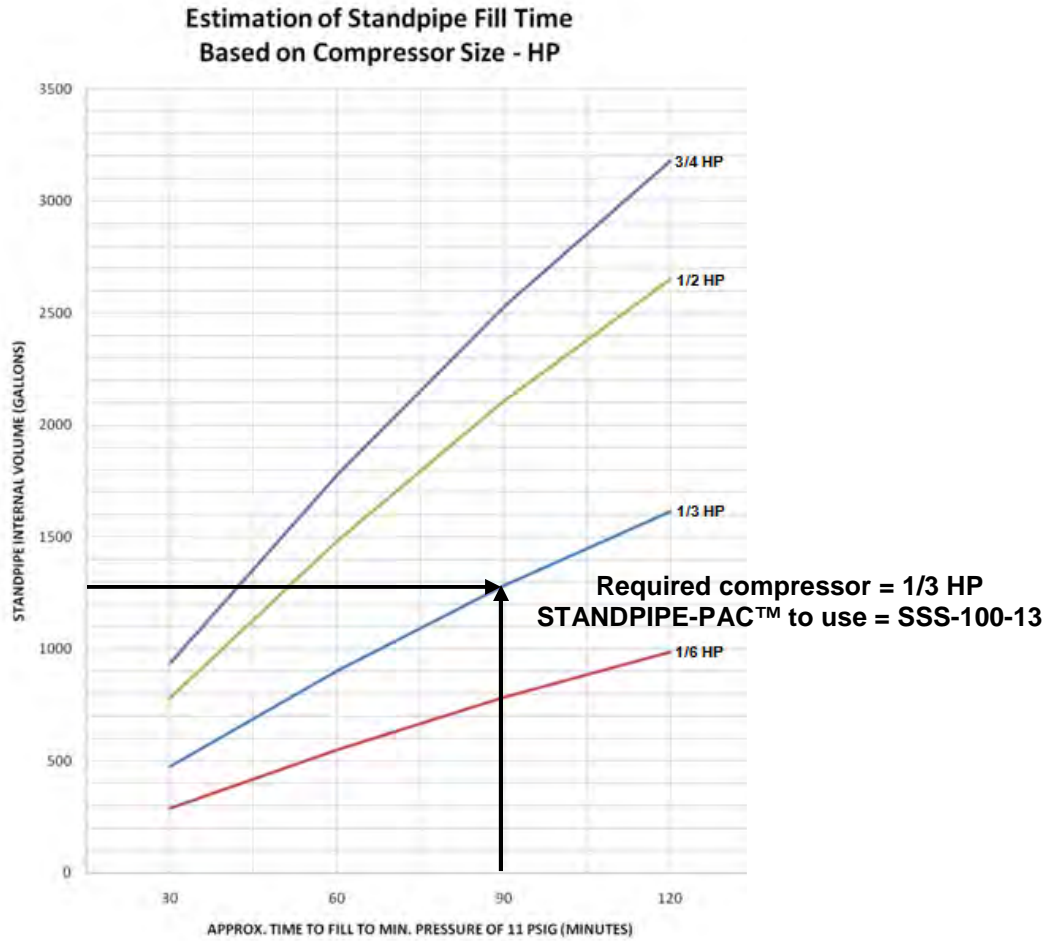

Figure 4 – Design Example 1

2.5. Example 2.

Nominal Pipe Size	Pipe Length in Feet		Gallons per Foot	Gallons
2"	80	X	0.174	14
6"	100	X	1.500	150
8"	550	X	2.600	1430
			TOTAL =	1594 gallons

Fill time of 1 hour (60 minutes) required.

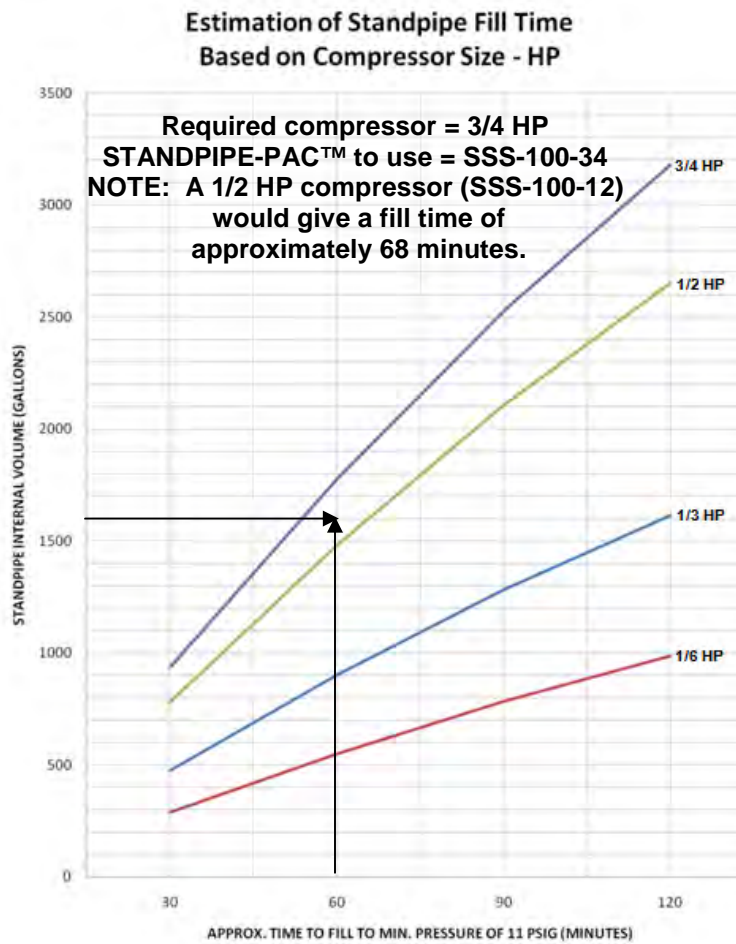

Figure 5 – Design Example 2

2.6. Options.

2.6.1. Additional Audible Signals. Additional audible signals can be added to the Notification Appliance Circuit (NAC) of the **STANDPIPE-PAC™** unit to permit hearing the alarm throughout the facility. Consult Appendix A of this manual for further information. See Paragraph 3.3.4.5 for installation instructions.



IMPORTANT

UNITED Fire Systems recommends that all devices connected to the Notification Appliance Circuit (NAC) of the **STANDPIPE-PAC™** unit be audible **ONLY**. Local Law 64 / BC 3303.8.1 requires only audible notification. Visual indicators, such as strobes, can easily be mistaken for fire alarm notification appliances. Signals from the **STANDPIPE-PAC™** unit are **NOT** fire alarm signals.

2.6.2. Off-Site Signaling Via Dialer. The STANDPIPE-PAC control unit is equipped with a built-in dialer for off-site signal notification. See Appendix D for proper hookup of telephone lines for this purpose.

3. INSTALLATION

3.1. Unpacking. Check shipment of the United Fire Systems **STANDPIPE-PAC™** system for damage. If there is any damage or missing parts, the transportation company's agent should make a notation to the effect on the Bill of Lading. Claims should be settled directly with the transportation company. Verify that all parts were received in the shipment as ordered. Contact the factory immediately if there are any missing parts or discrepancies. The following items should be with the shipment:

- **STANDPIPE-PAC™** unit – P/N SSS-100-XX (XX = compressor size)
- Manual air release bleed valve – P/N 06-100004-000
- Cap and chain for manual air release bleed valve – P/N 06-100004-001
- Nameplate for manual air release bleed valve – P/N 10-440001-001
- Standby battery (12 VDC 7.5 A-H) for control unit – P/N 03-100005-001
- Design, installation, operation, and maintenance manual – P/N 10-540000-001.



CAUTION

Understand and follow all safety recommendations when moving heavy pieces of equipment. Equipment may be easily tipped over when moving. Failure to use caution can result in equipment damage and personal injury.

3.2. Location. Due consideration must be given to all of the following considerations when locating the **STANDPIPE-PAC™** unit.

3.2.1. Engineering Drawings (if available). If a survey was conducted, and engineering drawings prepared, locate all equipment per these drawings.

3.2.2. Proximity. The **STANDPIPE-PAC™** unit should be installed in reasonably close proximity to the standpipe being protected. The most logical location is in the same room as the riser. If necessary, the device may be installed remotely. Documentation and signage should be clear to identify which equipment in remote locations is connected together.

3.2.3. Weight. Ensure that the mounting surface is capable of supporting the weight of the **STANDPIPE-PAC™** unit, with a clear safety margin. Consult a structural engineer when necessary to verify suitability of location.

3.2.4. Noise. The **STANDPIPE-PAC™** unit does emit noise when running. Consideration should be given to locating equipment where normal operating noise does not interfere with building operations.

3.2.5. Clearance. Sufficient clearance should be available after installation for maintenance operations to take place. Leave at least (3) feet of clearance for personnel to access equipment for maintenance.

3.2.6. Temperature. Ensure that the **STANDPIPE-PAC™** unit is not subject to freezing conditions. Although the compressed air leaving the **STANDPIPE-PAC™** is dried by the desiccant air dryer, and is therefore suitable for use with standpipes in un-heated areas, water in the piping between the air compressor and the desiccant dryer will freeze unless the **STANDPIPE-PAC™** unit is located where freezing conditions cannot occur.

3.3. Installation.

3.3.1. Mounting. See Figure 6. Mount the **STANDPIPE-PAC™** in the chosen mounting location.

- It is strongly recommended that the unit be mounted on a wall.
- The unit weighs approximately 86 lbs. Choose a wall with construction capable of supporting this weight, with a reasonable safety margin.
- Use good standard practice and appropriate fasteners.
- The back board may be drilled as needed for mounting. Do not drill holes too close to corners.
- Leave a minimum of 3 feet of clearance in front of unit for personnel to perform maintenance.

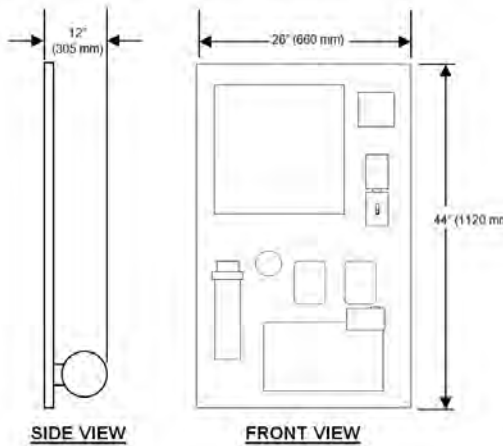

Figure 6 – Dimensions – **STANDPIPE-PAC™** Unit

3.3.2. Piping. See Figure 7. The piping in the red cloud is to be installed by the **STANDPIPE-PAC™** system installer. Use Sch. 40 black pipe and Class 150 fittings. The tee to connect the **STANDPIPE-PAC™** shall be located after the check valve, and should be located before the drain valve. Connect 1/2" pipe to point labeled OUTLET on **STANDPIPE-PAC™** unit. Ensure that the standpipe is NOT PRESSURIZED prior to cutting in the tee at the installation location.

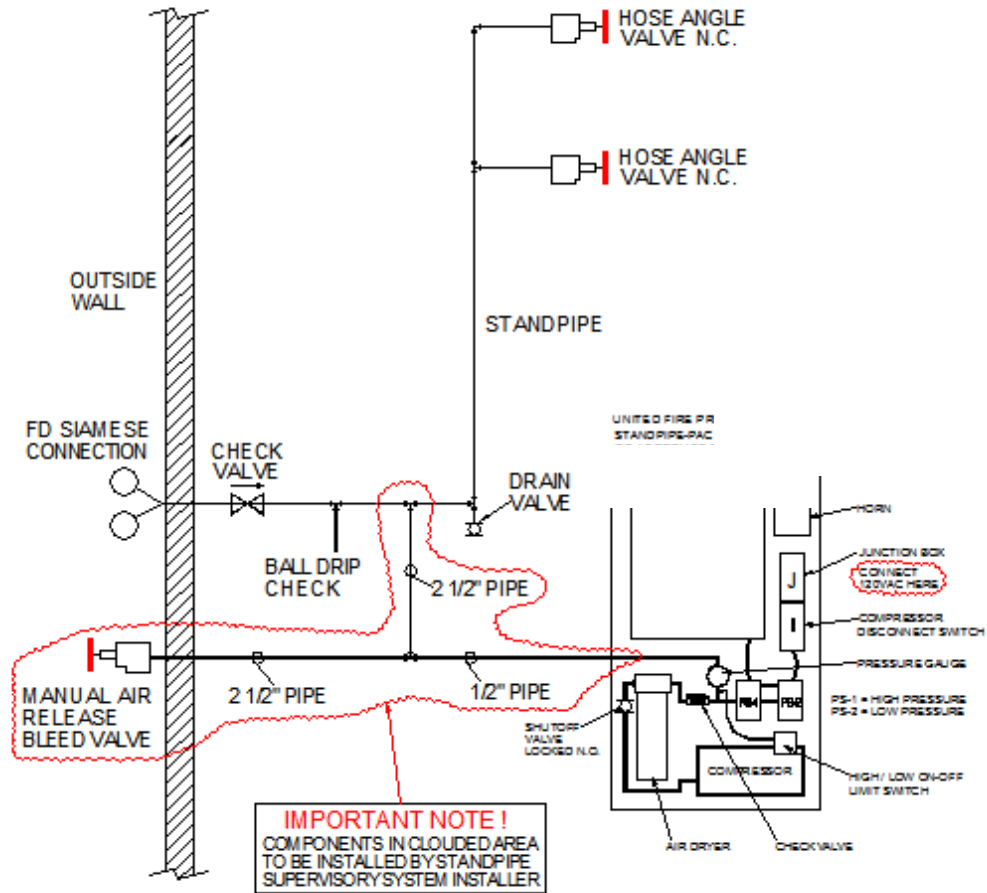

Figure 7 – **STANDPIPE-PAC™** Installation



CAUTION

Failure to confirm that the standpipe is NOT pressurized could result in personal injury and / or property damage.

3.3.3. Manual Air Release Bleed Valve. See Figure 2. Locate the manual air release bleed valve on the exterior of the building in proximity to the fire department siamese connection feeding the standpipe protected by the **STANDPIPE-PAC™**. Attach the cap and chain to the valve. Secure the provided nameplate to the building or the valve so that the fire department can clearly identify the purpose of the valve and follow the instructions on the nameplate.

3.3.4. Electrical Installation.



DANGER

RISK OF ELECTROCUTION

Voltages and currents associated with **STANDPIPE-PAC™** units are **LETHAL**. Follow all instructions provided. Work on **STANDPIPE-PAC™** unit power **MUST** be performed **ONLY** by qualified individuals. All required precautions to prevent contact with live electrical conductors and equipment **MUST** be taken. Failure to comply with these instructions is an immediate hazard with a likelihood of death or serious personal injury!

3.3.4.1. Codes. All **STANDPIPE-PAC™** wiring and wiring methods shall be in strict compliance with NEC and local codes.

3.3.4.2. Personnel. All wiring shall be performed by licensed electricians.

Part No.	Compressor Motor And Control Unit Voltage (V) / Phase Frequency (Hz)	Compressor Motor Horsepower (HP)	Compressor Motor Current (A)	Control Unit Current (A)	STANDPIPE-PAC™ Total Current (A)
SSS-100-16	115 / 1 / 60	1/6	6.6	0.7	7.3
SSS-100-13	115 / 1 / 60	1/3	6.6	0.7	7.3
SSS-100-12	115 / 1 / 60	1/2	8.0	0.7	8.7
SSS-100-34	115 / 1 / 60	3/4	10.6	0.7	11.3

Table 3 – Current Requirements – **STANDPIPE-PAC™** Units

3.3.4.3. Power Wiring. See Table 3. Choose minimum conductor sizes and overcurrent protective device based on total current shown in table. Connect power in junction box provided for the purpose – see Figure 1. When connecting power, ensure circuit breaker is OFF. Do not turn on circuit breaker until installation is complete and system is ready for commissioning.

UNITED FIRE SYSTEMS
 STANDPIPE-PAC™ MODEL SSS-100
 DESIGN, INSTALLATION, OPERATION, AND MAINTENANCE MANUAL
 REVISION 2.03
 P/N 10-540000-001

3.3.4.4. Battery Wiring. See Figure 8. **DO NOT** connect battery until commissioning.

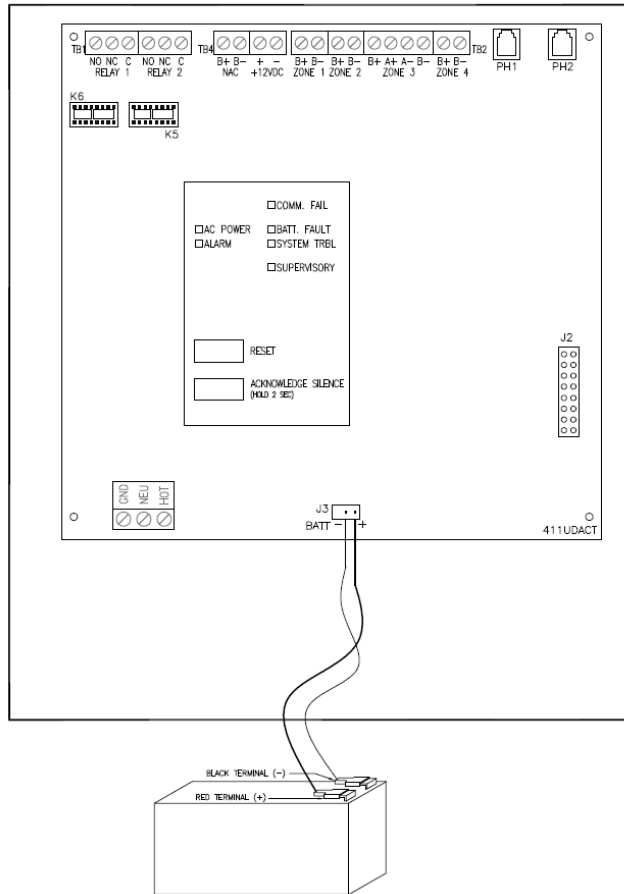

Figure 8 – Battery Wiring

3.3.4.5. Optional Signal Wiring. See Figure 9. If additional audible devices are desired, connect these devices to the notification appliance circuit serving the signal horn on the **STANDPIPE-PAC™** unit. See Appendix D for additional information, including power capacity of notification appliance circuit. Additional horns are available from UNITED Fire Systems – P/N 03-100006-201.

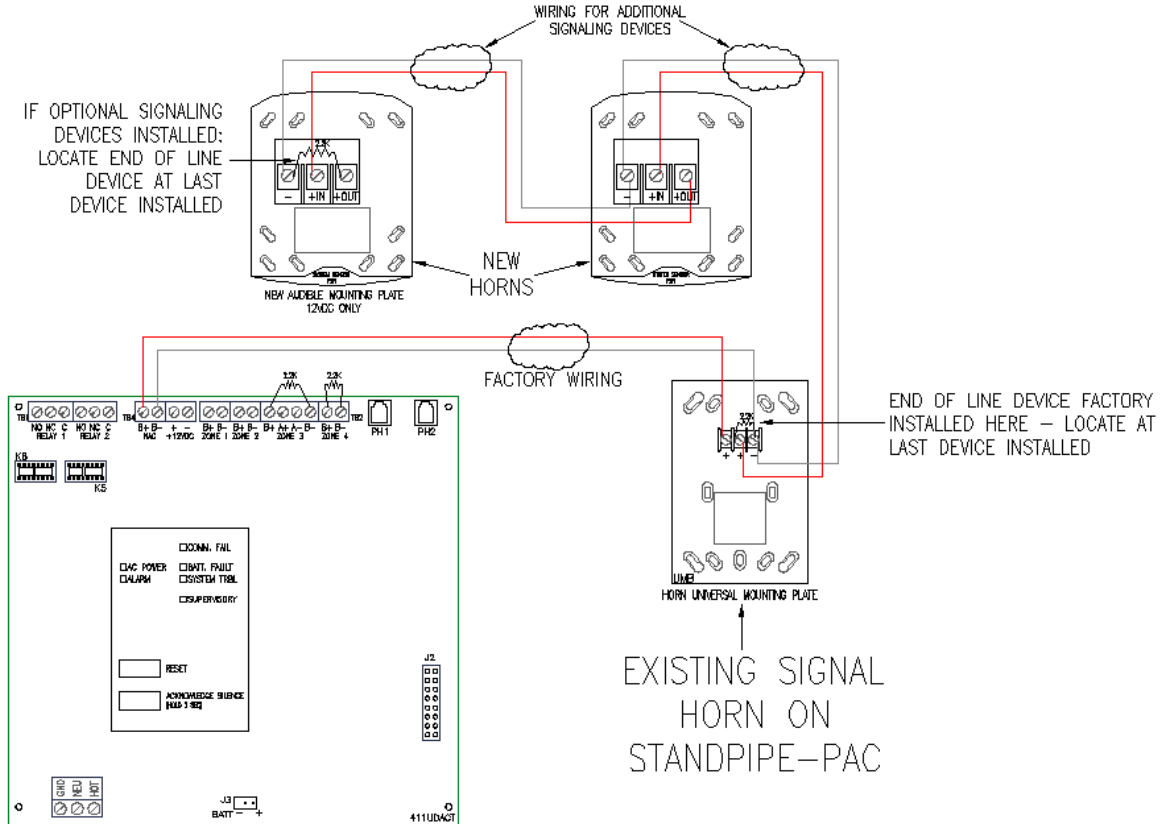



Figure 9 – Wiring Diagram – Notification Appliance Circuit



IMPORTANT

UNITED Fire Systems recommends that all devices connected to the Notification Appliance Circuit (NAC) of the **STANDPIPE-PAC™** unit be audible **ONLY**. Local Law 64 / BC 3303.8.1 requires only audible notification. Visual indicators, such as strobes, can easily be mistaken for fire alarm notification appliances. Signals from the **STANDPIPE-PAC™** unit are **NOT** fire alarm signals.

3.3.4.6. Optional Dialer Wiring. See Appendix D.



IMPORTANT

The **STANDPIPE-PAC™** unit, including control unit, has been pre-wired and programmed at the factory for proper operation. **DO NOT** alter any factory wiring or control unit programming. Failure to follow this instruction can result in improper **STANDPIPE-PAC™** operation and will void the factory warranty.

3.4. Commissioning.



IMPORTANT

The low- and high-limit pressure sensing switches, and the automatic control switch for the air compressor, have been factory-adjusted for proper operation per this manual. DO NOT attempt to adjust these switches without authorization from UNITED Fire Systems. These switches have factory-applied tamper seals. DO NOT break these seals. Failure to follow these instructions can lead to improper **STANDPIPE-PAC™** operation and will void the factory warranty.

3.4.1. Startup.



IMPORTANT

Pressure values indicated by the **STANDPIPE-PAC™** pressure gage are APPROXIMATE. Variation from nominal values can be expected.

STEPS TO FOLLOW FOR STANDPIPE-PAC™ SYSTEM STARTUP

Step No.	Description	Check When Complete
1		
2	Verify that all standpipe valves are CLOSED.	
3	Verify that manual air release bleed valve (see Figure 2) is CLOSED.	
4	Verify that 115 VAC power is available and connected. DO NOT turn on at present.	
5	Verify that lockable shutoff valve (see Figure 1 item 7) is OPEN.	
6	Verify that compressor disconnect switch (see Figure 1 item 12) is OFF.	
7	Open control unit (see Figure 1 item 8). Connect battery. See Figure 8.	
8	Turn 115 VAC circuit breaker ON.	
9	Press RESET button on control unit. AC POWER indicator should be ON.	
10	ALARM indicator should be ON. Signal horn should be sounding.	
11	Press SILENCE switch to acknowledge alarm. Press SILENCE switch again for 2 seconds to silence signal horn.	
12	Move compressor disconnect switch to ON. Compressor should start. Compressor is filling standpipe with air pressure.	
13	Verify that pressure gage needle (see Figure 1 item 5) is moving upward.	
14	When pressure gage needle reaches approximately 18 PSIG, compressor should automatically shut off.	
15	Control unit should be clear, with only AC POWER indicator ON.	
16	Proceed to 3.4.2 – TESTING.	

3.4.2. Testing

STEPS TO FOLLOW FOR STANDPIPE-PAC™ SYSTEM TESTING		
Step No.	Description	Check When Complete
### VERIFICATIONS BEFORE TESTING ###		
1	If control unit dialer is connected to telephone lines, ensure that party receiving signals is aware that testing activities are occurring.	
2	Verify that pressure gage (see Figure 1 item 5) indicates approximately 18 PSIG.	
3	Verify that control unit AC POWER indicator is ON and no other indicators are lit.	
### LOW-LIMIT PRESSURE-SENSING SWITCH and AUTOMATIC AIR COMPRESSOR CONTROL SWITCH TEST ###		
4	Verify that compressor disconnect switch (see Figure 1 item 12) is OFF.	
5	Move lockable shutoff valve (see Figure 1 item 7) to CLOSED position.	
6	Press and hold button on Test / Service Device (see Figure 1 item 13). Verify that pressure gage needle is moving DOWN.	
7	When pressure gage needle reaches approximately 7 PSIG, control unit ALARM indicator should be ON. Signal horn (see Figure 1 item 9) should sound.	
8	Release button on Test / Service Device.	
9	Press SILENCE switch to acknowledge alarm. Press SILENCE switch again for 2 seconds to silence signal horn.	
10	Move compressor disconnect switch to ON. Compressor should start. Pressure gage needle should move UP.	
11	When pressure gage needle moves above approximately 7 PSIG, control unit should clear and ALARM indicator should be OFF.	
12	When pressure gage needle reaches approximately 18 PSIG, compressor should automatically shut off.	
### HIGH-LIMIT PRESSURE-SENSING SWITCH TEST ###		
13	Verify that compressor disconnect switch is ON.	
14	Verify that lockable shutoff valve is in CLOSED position.	
15	Verify that control unit AC POWER indicator is ON and no other indicators are lit.	
16	Press and hold button on Test / Service Device. Verify that pressure gage needle is moving UP.	
17	When pressure gage needle reaches approximately 23 PSIG, control unit ALARM indicator should be ON. Signal horn should sound.	
18	Release button on Test / Service Device.	
19	Press SILENCE switch to acknowledge alarm. Press SILENCE switch again for 2 seconds to silence signal horn.	
20	Move compressor disconnect switch to OFF.	
21	Press and release button on Test / Service Device until pressure gage reads between 13 and 18 PSIG. Control unit ALARM indicator should be OFF. Signal horn should be OFF.	
22	Move compressor disconnect switch to ON.	
23	Move lockable shutoff valve to OPEN position.	
24	Pressure gage may drop. Compressor may start. Pressure gage should stabilize between 13 and 18 PSIG, and compressor should then be OFF.	
### STANDPIPE DEPRESSURIZATION TEST ###		
25	Remove cap from manual air release bleed valve. Open manual air release bleed valve all the way OPEN.	
26	Pressure gage reading should drop to 0 (zero) PSIG in approximately 3 minutes.	
27	Close manual air release bleed valve.	
28	Pressure gage reading should be approximately 13 PSIG (or more) in the design amount of time (see Section 2 – DESIGN).	
29	Proceed to 3.4.3 – PLACING IN SERVICE.	

3.4.3. Placing In Service.

STEPS TO FOLLOW FOR PLACING STANDPIPE-PAC™ SYSTEM IN SERVICE		
Step No.	Description	Check When Complete
1	Verify that compressor disconnect switch (see Figure 1 item 12) is ON.	
2	Verify that battery is properly connected to control unit (see Figure 8).	
3	Verify that control unit AC POWER indicator is ON and no other indicators are lit.	
4	Verify that pressure gage (see Figure 1 item 5) indicates approximately 18 PSIG.	
5	Place lock on lockable shutoff valve.	
6	Close and lock control unit door. It is recommended that one key be left in control unit lock.	
7	Deliver second control unit key, lockable shutoff valve key(s), and this manual to responsible individual at job site.	
8	If control unit dialer is connected to telephone lines, ensure that party receiving signals is aware that system is now in service.	
9	System is now in service.	

3.4.4. Troubleshooting.

Problem	Possible Cause	Solution	Manual Reference
No power to control panel or compressor.	Circuit breaker not on.	Turn circuit breaker on.	
	115 VAC not properly connected in junction box.	Properly connect power in junction box.	3.3.4.3
STANDPIPE-PAC™ does not build sufficient pressure in standpipe (less than 7 PSIG).	One or more outlet valves open.	Close all standpipe outlet valves.	
	Manual air release bleed valve open.	Close manual air release bleed valve.	
	Standpipe fitting connections are too leaky.	Inspect all fitting connections for tightness. Correct as necessary.	
	STANDPIPE-PAC™ is improperly sized.	Verify internal volume of standpipe. Ensure that proper STANDPIPE-PAC™ has been chosen.	Section 2
	Automatic air compressor control switch failure.	DO NOT ATTEMPT ADJUSTMENT OR REPAIR OF SWITCH. Contact UNITED Fire Systems or trained distributor for service.	
STANDPIPE-PAC™ builds too much pressure in standpipe (above 25 PSIG).	Automatic air compressor control switch failure.	DO NOT ATTEMPT ADJUSTMENT OR REPAIR OF SWITCH. Contact UNITED Fire Systems or trained distributor for service.	
STANDPIPE-PAC™ alarms too low (below 7 PSIG).	Low-limit pressure sensing switch requires adjustment.	DO NOT ATTEMPT ADJUSTMENT OR REPAIR OF SWITCH. Contact UNITED Fire Systems or trained distributor for service.	
STANDPIPE-PAC™ alarms too high (above 25 PSIG).	High-limit pressure sensing switch requires adjustment.	DO NOT ATTEMPT ADJUSTMENT OR REPAIR OF SWITCH. Contact UNITED Fire Systems or trained distributor for service.	

Troubleshooting (continued).

STANDPIPE-PAC™ does not alarm when manual air release bleed valve is opened.	Manual air release bleed valve cap is on.	Remove manual air release bleed valve cap.	
	Lockable shutoff valve is closed.	Open lockable shutoff valve.	
	Ice buildup in air dryer and unit piping.	Ensure that STANDPIPE-PAC™ is installed in area where temperature cannot go below 32 degrees F.	
Color of beads in air dryer has changed	Air dryer beads have absorbed water to their capacity.	Compare color of beads to decal on side of dryer. If beads are orange, contact UNITED Fire Systems or trained distributor for service.	
Excessive moisture in standpipe.			
Control unit has no power when circuit breaker is turned OFF.	Battery not properly connected.	Properly connect battery.	Figure 8
	Battery is discharged.	Permit control unit to charge batteries for 24 hours.	
	Battery is not capable of holding charge.	Battery requires replacement – Contact UNITED Fire Systems or trained distributor for service.	

4. OPERATION

4.1. Indicators.

4.1.1. Pressure Gage. The pressure gage indicates the approximate pressure produced by the air compressor within the **STANDPIPE-PAC™** piping and the standpipe.



IMPORTANT

Pressure values indicated by the **STANDPIPE-PAC™** pressure gage are APPROXIMATE. Variation from nominal values can be expected.

4.1.2. Signal Horn. The signal horn is the required audible indicator to annunciate an alarm condition. The signal horn will sound when the pressure in the standpipe drops below approximately 7 PSIG, indicating an impairment of the standpipe requiring correction.

4.1.3. Indicators Within Control Unit.

4.1.3.1. Visual Indicator – “AC POWER”. This is a green LED, visible with unit door closed or open, indicating that AC power has been applied to the unit.

4.1.3.2. Visual Indicator – “ACTIVE”. This is a red LED, visible with unit door closed or open, indicating that either the low-limit or high-limit pressure sensing switch has activated.

4.1.3.3. Visual Indicator – “COMM. FAIL”. This is a yellow LED, visible with unit door closed or open, indicating failure of communications over the telephone lines (if connected).

4.1.3.4. Visual Indicator – “BATT. FAULT”. This is a yellow LED, visible with unit door closed or open, indicating trouble with the backup battery.

4.1.3.5. Visual Indicator – “SYSTEM TRBL”. This is a yellow LED, visible with unit door closed or open, indicating a fault on a supervised circuit.

4.1.3.6. Visual Indicator – “SUPERVISORY”. This is a yellow LED that is not used with **STANDPIPE-PAC™**.

4.1.3.7. Visual Indicator – “GND FAULT”. This is a yellow LED, visible only with unit door open, indicating a ground fault on an external circuit.

4.1.3.8. Audible Indicator – Piezo Sounder. This is an audible indicator that sounds whenever an ACTIVE or SYSTEM TRBL signal exists.

4.2. Controls.

4.2.1. Lockable Shutoff Valve. This valve is used during testing and maintenance to isolate the **STANDPIPE-PAC™** from the standpipe. The normal position of this valve is OPEN. A lock should be placed on this valve to ensure it stays in the OPEN position, and is not closed inadvertently.

4.2.2. Compressor Disconnect Switch. This switch is used to remove power from the compressor during testing and maintenance. The normal position of this switch is ON.

4.2.3. Test / Service Device. This device is used ONLY during testing and maintenance. DO NOT operate this device unless testing and maintenance procedures are being followed.

4.2.4. Controls Within Control Unit.

4.2.4.1. Pushbutton – “RESET”. This pushbutton resets all control unit circuits.

4.2.4.2. Pushbutton – “ACKNOWLEDGE SILENCE (HOLD 2 SEC.)”.

4.2.4.2.1. Press this pushbutton ONCE to acknowledge signals. Piezo sounder is silenced, and all flashing visual indicators change to steady on.

4.2.4.2.2. Press a second time and HOLD for two (2) seconds to silence the Signal Horn.

4.3. Indications.

4.3.1. Normal Operation. Under normal operation, the following will be indicated:

NORMAL OPERATION		
INDICATOR or CONTROL	ITEM	STATUS
Visual Indicator	Pressure Gage	Indicating between 13 and 18 PSIG
Visual Indicator	AC POWER	ON
Visual Indicator	ACTIVE	Off
Visual Indicator	COMM. FAIL	Off
Visual Indicator	BATT. FAULT	Off
Visual Indicator	SYSTEM TRBL	Off
Visual Indicator	SUPERVISORY	Off
Visual Indicator	GND FAULT	Off
Audible Indicator	Piezo Sounder	Off
Audible Indicator	Signal Horn	Off
Control	Lockable Shutoff Valve	Open
Control	Compressor Disconnect Switch	ON
Control	Test / Service Device	Not Operated

4.3.2. Signal Operation – Low Pressure In Standpipe.



WARNING

Low pressure in the standpipe is an indication that the standpipe is **IMPAIRED**. Follow instructions under “Procedures – What To Do When Standpipe Is Impaired.” Failure to do so may result in death, personal injury, or serious property damage when firefighters cannot fight a fire.

When pressure drops within the standpipe, the following will be indicated:

LOW PRESSURE IN STANDPIPE		
INDICATOR or CONTROL	ITEM	STATUS
Visual Indicator	Pressure Gage	Indicating less than 7 PSIG
Visual Indicator	AC POWER	ON
Visual Indicator	ACTIVE	ON
Visual Indicator	COMM. FAIL	Off
Visual Indicator	BATT. FAULT	Off
Visual Indicator	SYSTEM TRBL	Off
Visual Indicator	SUPERVISORY	Off
Visual Indicator	GND FAULT	Off
Audible Indicator	Piezo Sounder	ON
Audible Indicator	Signal Horn	ON
Control	Lockable Shutoff Valve	Open
Control	Compressor Disconnect Switch	ON
Control	Test / Service Device	Not Operated

4.3.3. Signal Operation – High Pressure In Standpipe.



CAUTION

High pressure in the standpipe can lead to a delay in firefighter use of the standpipe. Follow instructions under “Procedures – What To Do If High Pressure Exists In Standpipe.” Failure to do so increases the risk of injury and property damage when firefighters are delayed when fighting a fire.

If pressure increases in standpipe above 25 PSIG, the following will be indicated:

HIGH PRESSURE IN STANDPIPE		
INDICATOR or CONTROL	ITEM	STATUS
Visual Indicator	Pressure Gage	Indicating 25 PSIG or more
Visual Indicator	AC POWER	ON
Visual Indicator	ACTIVE	ON
Visual Indicator	COMM. FAIL	Off
Visual Indicator	BATT. FAULT	Off
Visual Indicator	SYSTEM TRBL	Off
Visual Indicator	SUPERVISORY	Off
Visual Indicator	GND FAULT	Off
Audible Indicator	Piezo Sounder	ON
Audible Indicator	Signal Horn	ON
Control	Lockable Shutoff Valve	Open
Control	Compressor Disconnect Switch	ON
Control	Test / Service Device	Not Operated

4.4. Procedures

4.4.1. Normal Operation. Under normal operation, no intervention is needed.

NORMAL OPERATION		
INDICATOR or CONTROL	ITEM	STATUS
Visual Indicator	Pressure Gage	Indicating between 13 and 18 PSIG
Visual Indicator	AC POWER	ON
Visual Indicator	ACTIVE	Off
Visual Indicator	COMM. FAIL	Off
Visual Indicator	BATT. FAULT	Off
Visual Indicator	SYSTEM TRBL	Off
Visual Indicator	SUPERVISORY	Off
Visual Indicator	GND FAULT	Off
Audible Indicator	Piezo Sounder	Off
Audible Indicator	Signal Horn	Off
Control	Lockable Shutoff Valve	Open
Control	Compressor Disconnect Switch	ON
Control	Test / Service Device	Not Operated

4.4.2. To Silence Piezo Sounder. Press “ACKNOWLEDGE SILENCE (HOLD 2 SEC.)” pushbutton once.

4.4.3. To Silence Signal Horn(s). Press “ACKNOWLEDGE SILENCE (HOLD 2 SEC.)” pushbutton once, followed by pressing and holding the pushbutton for 2 seconds.

4.4.4. For Fire Department Use of Fire Standpipe.



WARNING

The fire standpipe **MUST** only be placed into use by the fire department. **DO NOT** use the standpipe for any other purpose. Failure to follow this warning may result in impairment of the standpipe in the event of fire, and may result in death, personal injury, or serious property damage when firefighters cannot fight a

- Open Manual Air Release Bleed Valve located in proximity to fire department siamese.
- Allow air to bleed from fire standpipe for 3 minutes.
- Close Manual Air Release Bleed Valve before pumping water into fire standpipe.

4.4.5. To Refill Standpipe With Air Pressure After Fire Department Use



CAUTION

After standpipe-has been filled with water for any reason, ensure that standpipe is completely empty of water before refilling standpipe with air pressure. Use all available drain points to remove all water from the standpipe. If, at any time, it is suspected that water has entered the **STANDPIPE-PAC™** unit, contact UNITED Fire Systems or your trained distributor before refilling standpipe with air pressure.

- Ensure that standpipe is completely drained of water, and no pressure remains in standpipe.
- Ensure that Compressor Disconnect Switch is ON, and all standpipe valves are closed.
- **STANDPIPE-PAC™** unit will refill standpipe with air.

TO REFILL STANDPIPE WITH AIR PRESSURE		
INDICATOR or CONTROL	ITEM	STATUS
Visual Indicator	Pressure Gage	Indicating less than 7 PSIG
Visual Indicator	AC POWER	ON
Visual Indicator	ACTIVE	ON
Visual Indicator	COMM. FAIL	Off
Visual Indicator	BATT. FAULT	Off
Visual Indicator	SYSTEM TRBL	Off
Visual Indicator	SUPERVISORY	Off
Visual Indicator	GND FAULT	Off
Audible Indicator	Piezo Sounder	ON
Audible Indicator	Signal Horn	ON
Control	Lockable Shutoff Valve	Open
Control	Compressor Disconnect Switch	ON
Control	Test / Service Device	Not Operated

4.4.6. To Test Standpipe with Water Pressure

- CLOSE Lockable Shutoff Valve BEFORE testing standpipe with water pressure.
- After standpipe has been filled with water, ensure that standpipe is completely empty of water BEFORE opening lockable shutoff valve. Use all available drain points to remove all water from the standpipe.
- Follow instructions in 4.4.5 to refill standpipe with air.



CAUTION

After standpipe-has been filled with water for any reason, ensure that standpipe is completely empty of water before refilling standpipe with air pressure. Use all available drain points to remove all water from the standpipe. If, at any time, it is suspected that water has entered the **STANDPIPE-PAC™** unit, contact UNITED Fire Systems or your trained distributor before refilling standpipe with air pressure.

5. MAINTENANCE. Maintenance is vitally important for the continued protection provided by the **STANDPIPE-PAC™** unit. Perform all maintenance according to the instructions in this manual.



RISK OF ELECTROCUTION

Voltages and currents associated with **STANDPIPE-PAC™** units are **LETHAL**. Follow all instructions provided. Work on **STANDPIPE-PAC™** unit power **MUST** be performed **ONLY** by qualified individuals. All required precautions to prevent contact with live electrical conductors and equipment **MUST** be taken. Failure to comply with these instructions is an immediate hazard with a likelihood of death or serious personal injury!



CAUTION

Before performing maintenance on the **STANDPIPE-PAC™** unit, confirm that the unit is **NOT** pressurized. Failure to confirm that the unit is **NOT** pressurized could result in personal injury and / or property damage.



IMPORTANT

The low- and high-limit pressure sensing switches, and the automatic control switch for the air compressor, have been factory-adjusted for proper operation per this manual. **DO NOT** attempt to adjust these switches without authorization from UNITED Fire Systems. These switches have factory-applied tamper seals. **DO NOT** break these seals. Failure to follow these instructions can lead to improper **STANDPIPE-PAC™** operation and will void the factory warranty.



IMPORTANT

Pressure values indicated by the **STANDPIPE-PAC™** pressure gage are **APPROXIMATE**. Variation from nominal values can be expected.



IMPORTANT

The **STANDPIPE-PAC™** unit, including control unit, has been pre-wired and programmed at the factory for proper operation. **DO NOT** alter any factory wiring or control unit programming. Failure to follow this instruction can result in improper **STANDPIPE-PAC™** operation and will void the factory warranty.

5.1. Weekly. Weekly maintenance consists of visual checks of the status of the STANDPIPE-PAC unit and the standpipe itself.

Item	Normal Status	Abnormal Status	What To Do If Status Is Abnormal
Check control panel visual indicators	AC Power Green LED – ON All other LED indicators - OFF	Any indicators other than AC Power ON	Contact your service provider for service.
Check Compressor Disconnect Switch	ON	OFF	Return Compressor Disconnect Switch to ON position.
Check Pressure Gage	Indicating between 13 to 18 PSIG	Indicating below 13 PSIG or above 18 PSIG	Contact your service provider for service.
Check Desiccant in Air Dryer	Blue color	Orange color	If desiccant is orange throughout, contact your service provider for service
Check Lockable Shutoff valve	Locked in OPEN position	Unlocked or CLOSED	Open valve and apply lock.
Check Manual Air Release Bleed Valve	Valve – CLOSED Cap – Attached to outlet of valve; chain intact and connected to valve	Valve – OPEN Cap – Disconnected or Missing	If valve is OPEN, CLOSE valve tightly. If cap is disconnected, re-connect. If cap is missing, contact service provider for replacement.
Check standpipe valves	All valves - CLOSED	Any valve OPEN	Ensure all valves are CLOSED.

5.2. Monthly. Monthly maintenance consists of quick checks of alarm response.

Item	Procedure	Normal Status	What To Do If Status Is Abnormal
Check High Alarm	1. Compressor disconnect switch ON. 1. Lockable shutoff valve CLOSED. 2. Operate test / service device.	Signal horn should sound when pressure gage indicates 23 ± 1 PSIG	Contact service provider
Check Low Alarm	1. Compressor disconnect switch OFF. 2. Lockable shutoff valve CLOSED. 3. Operate test / service device.	Signal horn should sound when pressure gage indicates 7 ± 1 PSIG.	Contact service provider
Return To Normal Status	1. Compressor disconnect switch ON. 2. Lockable shutoff valve OPEN. 3. Compressor should run until standpipe is properly filled.	1. Compressor off. 2. No abnormal indications on control panel. 3. Pressure gage indicates between 13 and 18 PSIG.	Contact service provider

5.3. Quarterly.



IMPORTANT

Quarterly maintenance as indicated below is vitally important for continued proper functioning of your **STANDPIPE-PAC™**. Please do **NOT** neglect these procedures!

5.3.1 Replacement of Desiccant In Dryer. It is important that the air dryer continue to remove moisture from the compressed air. For this reason, it is recommended that the dryer desiccant be replaced quarterly.

NOTE – Refer to illustration on Page 27.

1. Have Qty. (1) UFS P/N 21-100000-100 Replacement Desiccant available.
2. Notify local personnel that signals will be heard / seen during maintenance.
3. If dialer is connected to telephone line, notify receiving office that signals will be transmitted during maintenance.
4. Close lockable shutoff valve on outlet of STANDPIPE-PAC.
5. Move compressor disconnect switch to OFF.
6. De-pressurize STANDPIPE-PAC piping by operating Test / Service Device. Hold until pressure gage indicates ZERO.
7. Silence audible signal by opening door of control unit and operating Acknowledge-Silence button. Hold for 2 seconds until audible signal silences.



CAUTION

DO NOT turn connecting ring on desiccant air dryer unless pressure gage indicates ZERO. Failure to do so can result in personal injury and property damage.

8. Locate desiccant air dryer on STANDPIPE-PAC. Locate tab marked PUSH on connecting ring holding aluminum bowl in place (tab orientation may not be immediately visible).
9. Depress tab marked PUSH and turn connecting ring to release aluminum bowl and glass liner.
10. Detach aluminum bowl from assembly.
11. Remove and discard the desiccant beads in the bowl.
12. Fill glass liner with new desiccant beads to approximately the same level. Use Qty. (1) UFS P/N 21-100000-100.
13. Carefully align and insert desiccant bowl back into assembly until it is flush against air dryer cap.
14. Depress tab marked PUSH, and turn connecting ring until connection is re-established.
15. Release tab and ensure that aluminum bowl is secure.
16. Move compressor disconnect switch to ON. Compressor should start and pressure gage should begin to indicate.
17. When pressure gage reads approximately 18 PSIG, compressor should stop.
18. Check for leaks at air dryer connecting ring.
19. Open lockable shutoff valve on outlet of STANDPIPE-PAC.
20. Notify local personnel (and receiving office, if phone line is connected) that maintenance is complete.

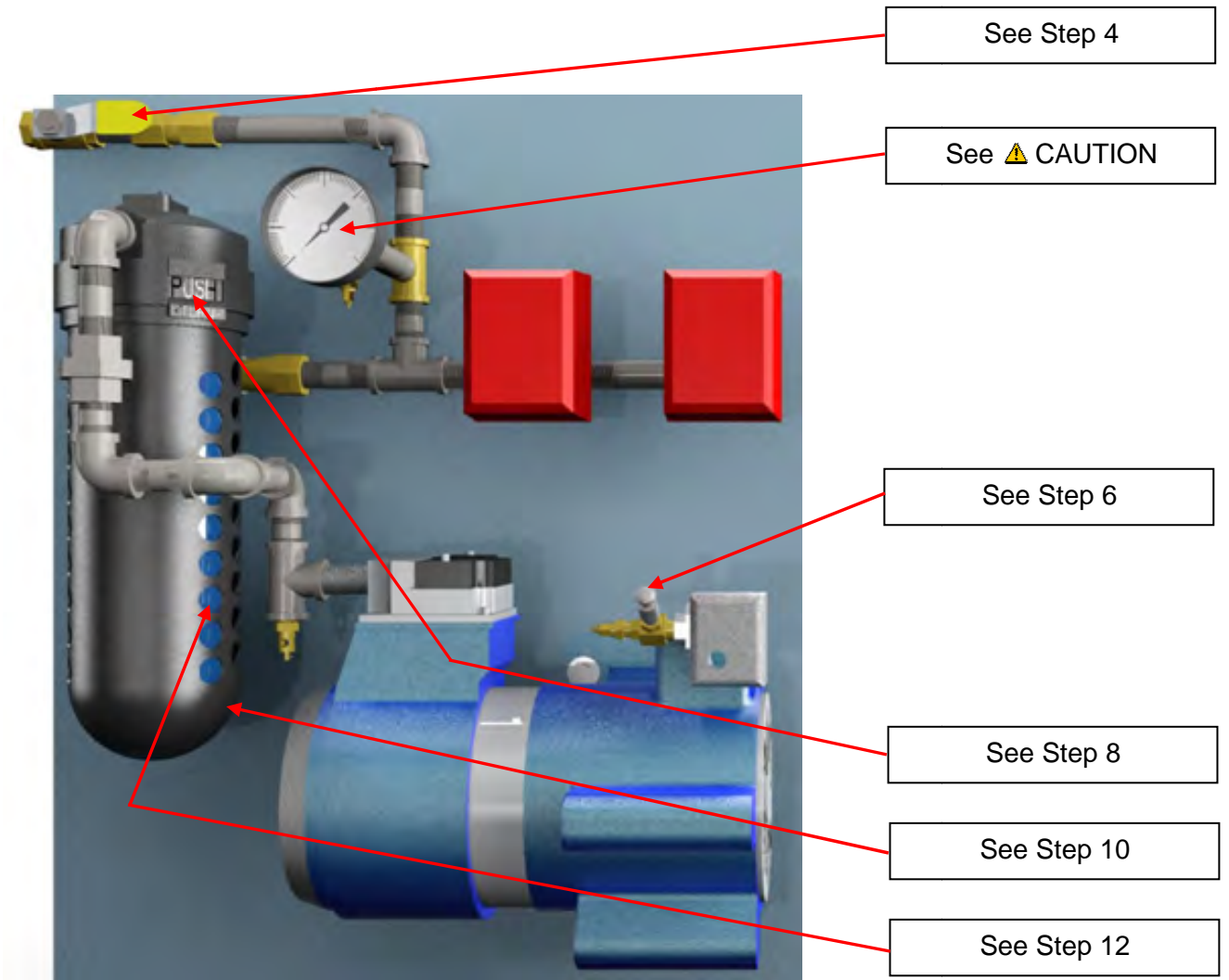

5.3.2. Replacement of Compressor Filter. The compressor filter keeps dust and other contaminants out of the compressor pump. Quarterly replacement can lengthen the lifespan of the compressor.

1. Have replacement filter kit UFS P/N 00-100005-553 available.
2. Move compressor disconnect switch to OFF.
3. Use 5/32" hex key to remove (2) hex screws holding black filter housing in place.
4. Remove filter housing.
5. Remove and discard existing foam filter element.
6. Replace with new foam filter element from replacement filter kit.
7. Replace black filter housing.
8. Secure filter housing with (2) hex screws using 5/32" hex key to tighten. Do not over-tighten.
9. Move compressor disconnect switch to ON.

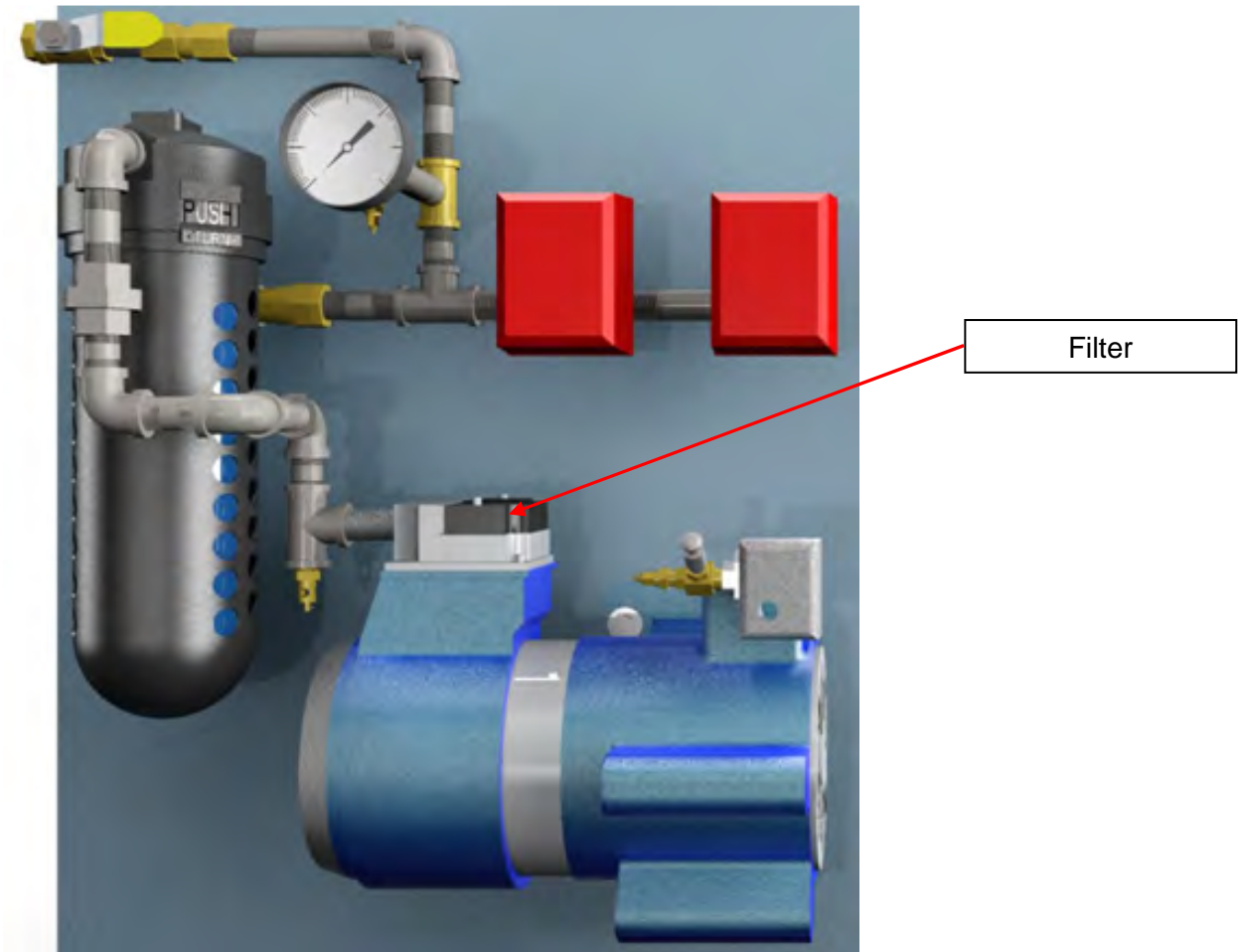

5.3.3 When quarterly maintenance is complete, sign and date the Quarterly Maintenance Tag. Enter date when next quarterly maintenance is due.



3825 Ohio Avenue, St. Charles, Illinois 60174
 1-800-SENSOR2, FAX: 630-377-6495
 www.systemsensor.com

EPS10 Series Alarm Pressure Switches

SPECIFICATIONS

Contact Ratings:	10 A, 1/2 HP @ 125/250 VAC ~
	8 A, 125/250 VAC (LPCB only)
	2.5A @ 6/12/24 VDC - - -
Overall Dimensions:	See Figure 1
Operating Temperature Range:	-40° to +160°F
Maximum Service Pressure:	300 PSI
Maximum Adjustment Range:	4 - 20 PSI
Enclosure Rating:	UL 4x — Indoor or Outdoor Use NEMA 4 — Indoor or Outdoor Use IP54
Approximate Differential:	3 PSI throughout range

FIGURE 1. PRESSURE SWITCH BASIC DIMENSIONS:

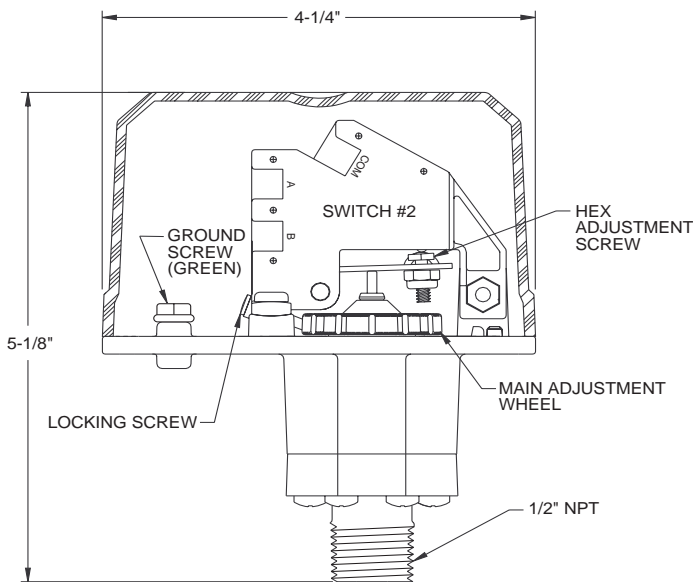

W0170-00

IMPORTANT

Please Read Carefully and Save

This instruction manual contains important information about the installation and operation of alarm pressure switches. Purchasers who install switches for use by others must leave this manual or a copy of it with the user.

Read all instructions carefully before installation, following only those instructions that apply to the model you are installing.

Before installing any alarm device, be thoroughly familiar with:

NFPA 72: *Installation, Maintenance, and Use of Protective Signaling Systems*

NFPA 13: *Installation of Sprinkler Systems*

NFPA 13A: *Inspection, Testing, and Maintenance of Sprinkler Systems*

Other applicable NFPA standards, local codes, and the requirements of the authority having jurisdiction.

Failure to follow these directions may result in failure of the device to report an alarm condition. System Sensor is not responsible for devices that have been improperly installed, tested, or maintained.



Do not use in potentially explosive atmospheres. Do not leave unused wires exposed.

OPERATION

As pressure changes, a diaphragm actuates 1 or 2 snap action switches. The pressure switch actuation is determined by adjustment settings.

INSTALLATION

- Remove Cover
Cover is held on by two tamper resistant screws. (Removal key is enclosed with pressure switch.)
- Mounting the Switch
The device is designed to be mounted in the upright or horizontal position; side mounting is also acceptable. Locate it where vibration, shock, and mechanical loading are minimal. Refer to piping diagram (Figure 2 on page 2).
 - Mount the device directly to the line via the 1/2" NPT pressure connection. The use of teflon pipe sealant tape is recommended. Be sure the fitting is tight enough to prevent leaks.
 - Apply tightening torque to the black plastic hex portion of device.



High voltage. Electrocutation hazard. Do not handle live AC wiring or work on a device to which AC power is applied. Doing so may result in severe injury or death. When utilizing switches at voltages greater than 74 VDC - - - or 49 VAC ~, means to provide all-pole disconnection must be incorporated in the field wiring, such as a circuit breaker.

- Wire the device in accordance with the National Electrical Code. Two 7/8" diameter conduit connection holes have been provided in the mounting plate to accept standard 1/2" conduit fittings (one is removable knock-out type). If a NEMA 4/UL 4x (waterproof unit) is required, waterproof flexible metallic conduit and appropriate conduit fittings must be used. Recommended connectors are Thomas and Betts PN 5332 (180° coupling), PN 5352 (90° coupling), and PN 5262 seal ring.
- Connect wiring to terminals (see Figure 3 and Table 1).

TABLE 1. ELECTRICAL CONNECTIONS (REFERENCED AT FACTORY SETTINGS):

MODEL EPS10-1	
SWITCH AT 0 P.S.I.	
B	— X
COM	—
A	— X
SWITCH AT 4-8 P.S.I. (HIGH TRIP PT.)	
B	— X
COM	—
A	— X
SWITCH 1	

FIGURE 3. SWITCH TERMINALS:

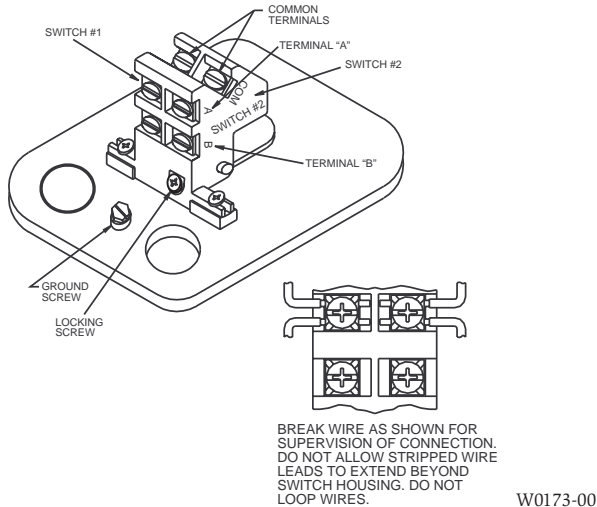

ADJUSTMENTS TO FACTORY SETTINGS

EPS10-1 devices are pre-adjusted at the factory to alarm at 4–8 PSI on rising pressure (see Table 2). Pressure switch settings may be adjusted in the field to obtain a different pressure alarm response from 4 PSI to 20 PSI. The switch has an override feature on the adjustment mechanism to prevent exceeding the 20 PSI max. setting of the switch. This override feature carries with it a tolerance band that may limit the upper adjustment to 16–20 PSI. Care must be used when setting the switch to ensure that the lower limit of 4 PSI is not exceeded. This will allow the switch to reset within the 3 PSI differential stated.

1. Install pressure switch as stated in “INSTALLATION” portion of instruction manual. Attach pressure test source to system.
2. Back off locking screw (see Figure 1) to allow main adjustment wheel to rotate freely.
3. Test trip point by slowly introducing pressure from the pressure test source. When trip point is found, reduce pressure to zero. Rotate main adjustment wheel (counterclockwise to increase pressure) and retest until switch trip point is at the desired pressure setting (4–20 PSI range).

Each number represents an approximate trip point change of 0.2 PSI. One full rotation changes the trip point setting by approximately 2.5 PSI. A reset differential of approximately 3 PSI is typical throughout the entire adjustment range of switch.

4. Retest the set point several times to ensure accuracy of setting.
5. Re-seat locking screw.

TABLE 2.

MODEL	FACTORY SETTINGS (PSI)			
	Fall (Low Switch)	Approx. Reset	Rise (High Switch)	Approx. Reset
EPS10-1	—	—	4 – 8	3 PSI diff.

NOTE: The sensor assembly is not field replaceable. Do not attempt to disassemble these parts. If you have any questions, consult System Sensor. System Sensor recommends careful consideration of the following factors when specifying and installing Alarm Pressure Switches. Always refer to the Installation and Maintenance Instruction for specific recommendations on individual devices before installing the unit.

- Electrical ratings stated in literature and on nameplates should not be exceeded.
- Overload on switch can cause failure on the first cycle. Always wire devices according to national and local electrical codes.
- Install units away from shock and vibration. Proper electrical fittings should be used to prevent moisture from entering the enclosure via the conduit.
- Test all devices for proper operation after initial installation. Perform preventive maintenance and periodic testing as required by the applicable NFPA standards but not less than bimonthly.
- Install a back-up control for all critical applications where control failure could endanger life or property. A backup control to serve as a high or low limit control is especially recommended for applications where a runaway condition could result.
- Do not mount unit where ambient temperatures will exceed published limits.
- Avoid impact or mechanical loading.

Please refer to insert for the Limitations of Fire Alarm Systems

THREE-YEAR LIMITED WARRANTY

System Sensor warrants its enclosed pressure switch to be free from defects in materials and workmanship under normal use and service for a period of three years from date of manufacture. System Sensor makes no other express warranty for this pressure switch. No agent, representative, dealer, or employee of the Company has the authority to increase or alter the obligations or limitations of this Warranty. The Company’s obligation of this Warranty shall be limited to the repair or replacement of any part of the pressure switch which is found to be defective in materials or workmanship under normal use and service during the three year period commencing with the date of manufacture. After phoning System Sensor’s toll free number 800-SENSOR2 (736-7672) for a Return Authorization number, send defective units postage prepaid to: System Sensor, Return

Department, RA # _____, 3825 Ohio Avenue, St. Charles, IL 60174. Please include a note describing the malfunction and suspected cause of failure. The Company shall not be obligated to repair or replace units which are found to be defective because of damage, unreasonable use, modifications, or alterations occurring after the date of manufacture. In no case shall the Company be liable for any consequential or incidental damages for breach of this or any other Warranty, expressed or implied whatsoever, even if the loss or damage is caused by the Company’s negligence or fault. Some states do not allow the exclusion or limitation of incidental or consequential damages, so the above limitation or exclusion may not apply to you. This Warranty gives you specific legal rights, and you may also have other rights which vary from state to state.



SPECIFICATIONS

Contact Ratings:	10 A, 1/2 HP @ 125/250 VAC ~	
	8A @ 125/250 VAC ~ (LPCB ONLY)	
	2.5A @ 6/12/24 VDC - - -	
Overall Dimensions:	See Figure 1	
Operating Temperature Range:	-40°F to +160°F	
Maximum Service Pressure:	EPS40-1,	300 PSI
Adjustment Range:	EPS40-1,	10-100 PSI
Enclosure Rating:	UL 4x — Indoor or Outdoor Use NEMA 4 — Indoor or Outdoor Use IP54	
Approximate Differential:	EPS40-1,	3 PSI at 10 PSI 6 PSI at 100 PSI

IMPORTANT

Please Read Carefully and Save

This instruction manual contains important information about the installation and operation of supervisory pressure switches. Purchasers who install switches for use by others must leave this manual or a copy of it with the user. Read all instructions carefully before installation, following only those instructions that apply to the model you are installing.

Before installing any alarm device, be thoroughly familiar with:

- NFPA 72: National Fire Alarm Code
- NFPA 13: Installation of Sprinkler Systems
- NFPA 25: Inspection, Testing, and Maintenance of Water-based Fire Protection Systems
- NFPA 13D: Standard for 1 and 2 Family Dwellings and Manufactured Homes
- NFPA 13R: Standard for Multi-family Dwellings

Other applicable NFPA standards, local codes, and the requirements of the authority having jurisdiction.

Failure to follow these directions may result in failure of the device to report an alarm condition. System Sensor is not responsible for devices that have been improperly installed, tested, or maintained.

CAUTION

Do not use in potentially explosive atmospheres. Do not leave unused wires exposed.

OPERATION

As pressure changes, a diaphragm actuates 1 or 2 snap action switches. The pressure switch actuation is determined by adjustment settings.

INSTALLATION

1. Remove Cover
Cover is held on by two screws.
2. Mounting the Switch
The device is designed to be mounted in the upright position; side mounting is also acceptable. Locate it where vibration, shock, and mechanical loading are minimal. Refer to piping diagram above (Fig. 2 and 3).
 - a. Mount the device directly to the line via the 1/2" NPT pressure connection. The use of teflon pipe sealant tape is recommended. Be sure the fitting is tight enough to prevent leaks.
 - b. Apply tightening torque to the black plastic hex portion of the device.

WARNING

High voltage. Electrocution hazard. Do not handle live AC wiring or work on a device to which AC power is applied. Doing so may result in severe injury or death. When utilizing switches at voltages greater than 74 VDC - - - or 49 VAC ~, means to provide all-pole disconnection must be incorporated in the field wiring, such as a circuit breaker.

3. Wire the device in accordance with the National Electrical Code. Two 7/8" diameter conduit connection holes have been provided in the mounting plate to accept standard 1/2" conduit fittings (one is removable knock-out type). If a NEMA 4/UL 4x (waterproof unit) is required, waterproof flexible metallic conduit and appropriate conduit fittings must be used. Recommended connectors are Thomas and Betts PN 5332 (180° coupling), PN 5352 (90° coupling), and PN 5262 seal ring.
 4. Connect wiring to terminals (see Figure 4 and Table 1).
- Adjustments to Factory Settings

FIGURE 1. PRESSURE SWITCH BASIC DIMENSIONS:

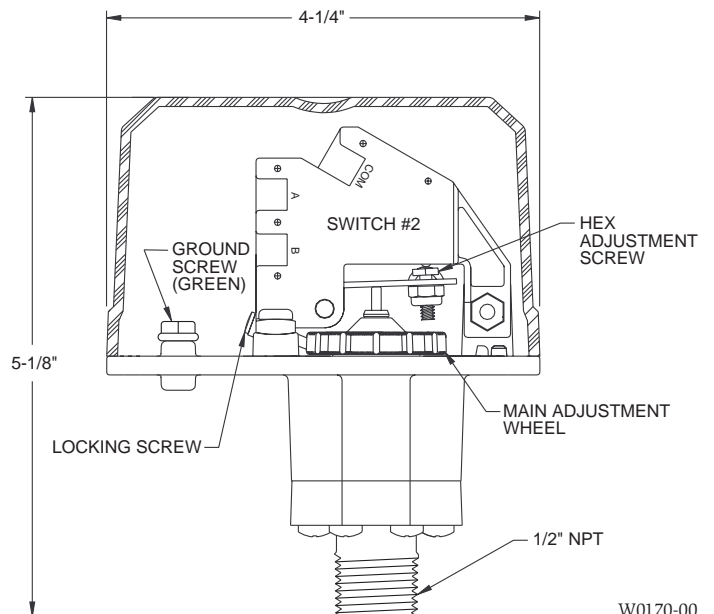

W0170-00

TABLE 2.

MODEL	FACTORY SETTINGS (PSI)		
	Fall SW2 (Low Switch)	Nominal	Rise SW1 (Hi Switch)
EPS40-1	30± 1.5	40	—

SINGLE-SWITCH MODEL — EPS40-1 AND EPS120-1

1. Install pressure switch as stated in “INSTALLATION” portion of instruction manual. Attach pressure test source to system.
2. Back off locking screw (see Fig. 4) to allow main adjustment wheel to rotate freely.
3. Test the switch for the set point by introducing 40 PSI pressure from the pressure test source for the EPS40-1. Decrease pressure slowly until the switch trips. Rotate main adjustment wheel, Figure 5, (counterclockwise to increase pressure) and retest by first introducing a higher pressure than desired and slowly reducing pressure until the switch trips. Repeat process until switch trip point is at desired pressure setting. Each number represents an approximate trip point change of 1.8 PSI for the EPS40-1. For each 1/2 rotation of the adjustment wheel, the trip point setting changes by approximately 11 PSI for the EPS40-1.
4. Retest the set point several times to ensure accuracy of setting.
5. Re-seat locking screw.

FIGURE 4. SWITCH LOCATION:

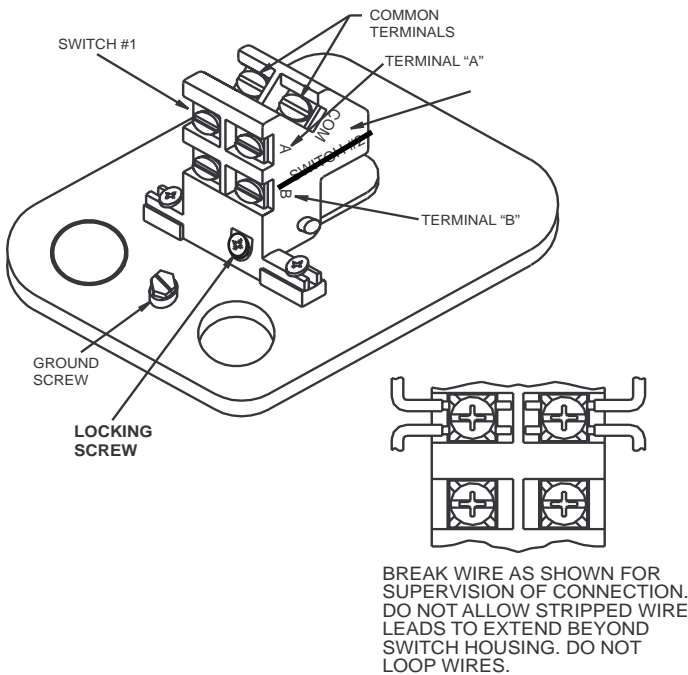

W0185-01

TABLE 1. ELECTRICAL CONNECTIONS (REFERENCED AT FACTORY SETTINGS):

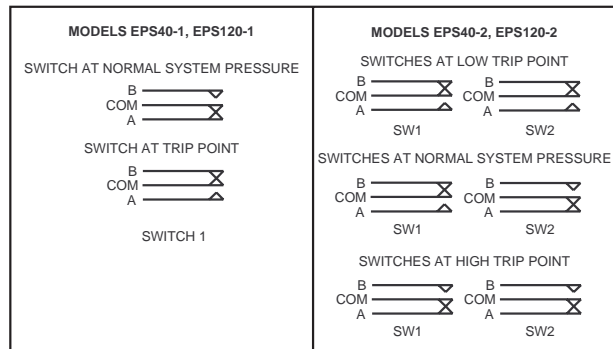

W0186-00

NOTE: The sensor assembly is not field replaceable. Do not attempt to disassemble these parts. If you have any questions, consult System Sensor. System Sensor recommends careful consideration of the following factors when specifying and installing Alarm and Supervisory Pressure Switches. Always refer to the Installation and Maintenance Instruction for specific recommendations on individual devices before installing the unit.

- Electrical ratings stated in literature and on nameplates should not be exceeded.
- Overload on switch can cause failure on the first cycle. Always wire devices according to national and local electrical codes.
- Install units away from shock and vibration. Proper electrical fittings should be used to prevent moisture from entering the enclosure via the conduit.
- Test all devices for proper operation after initial installation. Perform preventive maintenance and periodic testing as required by the applicable NFPA standards but not less than bimonthly.
- Install a back-up control for all critical applications where control failure could endanger life or property. A backup control to serve as a high or low limit control is especially recommended for applications where a runaway condition could result.
- Do not mount unit where ambient temperatures will exceed published limits.
- Avoid impact or mechanical loading.

FIGURE 5. ADJUSTMENTS (DUAL-SWITCH MODEL SHOWN):

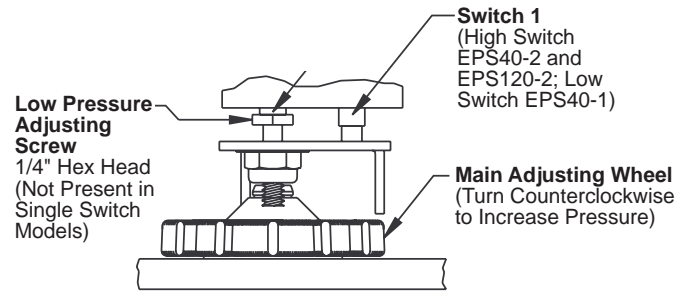

NOTE: Each 1/2 turn of Low Pressure adjusting screw adjusts pressure approximately 5 psi. Turn counter clockwise to increase pressure. Turn clockwise to decrease pressure. Each 1/2 turn of High Pressure adjusting wheel adjusts pressure 11 psi on the EPS40-

W0144-02

Please refer to insert for the Limitations of Fire Alarm Systems

THREE-YEAR LIMITED WARRANTY

System Sensor warrants its enclosed pressure switch to be free from defects in materials and workmanship under normal use and service for a period of three years from date of manufacture. System Sensor makes no other express warranty for this pressure switch. No agent, representative, dealer, or employee of the Company has the authority to increase or alter the obligations or limitations of this Warranty. The Company's obligation of this Warranty shall be limited to the repair or replacement of any part of the pressure switch which is found to be defective in materials or workmanship under normal use and service during the three year period commencing with the date of manufacture. After phoning System Sensor's toll free number 800-SENSOR2 (736-7672) for a Return Authorization number, send defective units postage prepaid to: System Sensor, Return

Department, RA # _____, 3825 Ohio Avenue, St. Charles, IL 60174. Please include a note describing the malfunction and suspected cause of failure. The Company shall not be obligated to repair or replace units which are found to be defective because of damage, unreasonable use, modifications, or alterations occurring after the date of manufacture. In no case shall the Company be liable for any consequential or incidental damages for breach of this or any other Warranty, expressed or implied whatsoever, even if the loss or damage is caused by the Company's negligence or fault. Some states do not allow the exclusion or limitation of incidental or consequential damages, so the above limitation or exclusion may not apply to you. This Warranty gives you specific legal rights, and you may also have other rights which vary from state to state.

(THIS SURFACE DELIBERATELY LEFT BLANK)

⚠ WARNING

To avoid unpredictable system behavior that can cause personal injury and property damage:

- Disconnect electrical supply (when necessary) before installation, servicing, or conversion.
- Disconnect air supply and depressurize all air lines connected to this product before installation, servicing, or conversion.
- Operate within the manufacturer's specified pressure, temperature, and other conditions listed in these instructions.
- Medium must be moisture-free if ambient temperature is below freezing.
- Service according to procedures listed in these instructions.
- Installation, service, and conversion of these products must be performed by knowledgeable personnel who understand how pneumatic products are to be applied.
- After installation, servicing, or conversion, air and electrical supplies (when necessary) should be connected and the product tested for proper function and leakage. If audible leakage is present, or the product does not operate properly, do not put into use.
- Warnings and specifications on the product should not be covered by paint, etc. If masking is not possible, contact your local representative for replacement labels.

Safety Guide

For more complete information on recommended application guidelines, see the Safety Guide section of Pneumatic Division catalogs or you can download the **Pneumatic Division Safety Guide** at: www.wilkersoncorp.com

Description

Wilkerson Manual Dryers are intended to remove water vapor from the compressed air system. Atmospheric dew points as low as -100°F (-73°C) are achievable when operated within rated unit specifications.

General Safety Information

- **Release all air pressure from intended airline before installation.**
- Install unit in air line before opening desiccant container. After unit installation, add desiccant following steps in desiccant replacement instructions on page 2.
- Always make sure bowl, bowl guard, and clamp ring are in place and the clamp ring is securely locked before pressurization.
- **DO NOT** exceed the pressure and temperature ratings as shown in the specifications.
- Follow all local, state and federal EPA, OSHA, and similar codes regarding disposal of old desiccant.



X03 Plastic Bowl

Specifications	
Maximum Pressure	150 psig (10.3 bar)
Maximum Temperature	125°F (52°C)
Atmospheric Dewpoint*	000 Model: -45°F (-43°C)
000 Model: Silica Gel	
Maximum Continuous Airflow*	10 scfm (4,7 dm ³ /s)
Total Airflow*	4400 scf (2076 dm ³)
Total Min. of Operation @ Max Continuous Airflow	440 min.
Unit Weight With Desiccant	7.4 lbs. (3.4 kg)
# of Desiccant Bags/Charge	2 Bags ***
Pipe Connections	1/4", 1/2" NPT (BSPP)

Installation

1. Refer to **WARNING** (on page 6).
2. Install as close as possible to the point where the air is being used.
3. Install unit with the airflow going in the direction of the arrow.
4. Install unit on air line before opening desiccant container. After installation, add desiccant. Shake and tap bowl while filling to settle desiccant. Fill Model X25 and X03/X04 to 1/8" below inner shoulder of bowl. Fill Model X06 bowl to within 1/2" of top.
5. Replace bowl and bowl guard, or metal bowl, and clamp ring onto the unit. Be sure clamp ring is securely locked in place before pressurizing unit.
6. Most manual desiccant dryer users will achieve optimal results when installing the dryer as close to the equipment or process being protected as possible in the compressed air system. Most users, especially those with high quality air requirements, should protect their system and the manual dryer with one or more of the following types of components:
Please see page 4 for exact model recommendations.

- **Liquid Separator:** Should be used prior to the manual desiccant dryer in any system where large slugs of liquid water are anticipated. The manual desiccant dryer silica gel or mole sieve can be destroyed by large amounts of liquid moisture. Most systems which have an aftercooler and separator, and/or a refrigerated air dryer, will not require a liquid separator. An alternative is to use a particulate filter/separator, described below.
- **Particulate Filter/Separator:** Should be used prior to the manual desiccant dryer in any system where significant amounts of dirt, pipe scale, etc, and/or liquid water, is present, in order to prevent clogging the manual dryer or harming the desiccant. A particulate filter/separator should be used prior to a coalescing filter to extend the life of the coalescing element.

*** Each bag weighs .88 lbs. (.40kg)

Models X06, X03, X04, and X25

d. See replacement parts list for specifics on kit numbers for replacement desiccant.

3. Desiccant regeneration:

a. — For silica gel ("000") units: Pour out used Pink desiccant onto flat pan. Place Pink desiccant in 350°F (176°C) oven for approximately three hours or until the desiccant color has changed back to Blue.

b. Remove desiccant from oven and allow to cool down to ambient temperature.

c. Pour desiccant back into unit bowl, periodically shaking and tapping to settle the desiccant.

4. Replace bowl and bowl guard, or metal bowl, and clamp ring onto the unit. Be sure clamp ring is securely locked in place before repressurizing the unit.

Operation

1. The silica gel desiccant, when visible through the clear polycarbonate plastic bowl, contains a color indicator. It changes from Blue (meaning dry) to Pink (meaning wet) to indicate the need to replace or regenerate the desiccant.

Maintenance

1. The only servicing required for silica gel units is when the desiccant color or moisture indicator has changed from Blue (meaning dry) to Pink (meaning wet). Should this color change occur:

- Turn off and depressurize the line containing the dryer unit.
- Loosen the clamp ring and remove the bowl from the top housing. (Figure 1) Proceed to step 2 or 3, as required.

2. Desiccant replacement:

- Pour out used desiccant.
- Open new container and refill bowl. (Figure 2)
- Shake or tap bowl to settle desiccant. Add or remove sufficient quantity to fill Model X03 unit bowl to 1/8" below inner step,

CAUTION

Polycarbonate bowls, being transparent and tough, are ideal for use with Filters and Lubricators. They are suitable for use in normal industrial environments, but should not be located in areas where they could be subjected to direct sunlight, an impact blow, nor temperatures outside of the rated range. As with most plastics, some chemicals can cause damage. Polycarbonate bowls should not be exposed to chlorinated hydrocarbons, ketones, esters and certain alcohols. They should not be used in air systems where compressors are lubricated with fire-resistant fluids such as phosphate ester and di-ester types.

Metal bowls are recommended where ambient and/or media conditions are not compatible with polycarbonate bowls. Metal bowls resist the action of most such solvents, but should not be used where strong acids or bases are present or in salt laden atmospheres. Consult the factory for specific recommendations where these conditions exist.

TO CLEAN POLYCARBONATE BOWLS USE MILD SOAP AND WATER ONLY! DO NOT use cleansing agents such as acetone, benzene, carbon tetrachloride, gasoline, toluene, etc., which are damaging to this plastic.

Bowl guards are recommended for added protection of polycarbonate bowls where chemical attack may occur.

WARNING

FAILURE OR IMPROPER SELECTION OR IMPROPER USE OF THE PRODUCTS AND/OR SYSTEMS DESCRIBED HEREIN OR RELATED ITEMS CAN CAUSE DEATH, PERSONAL INJURY AND PROPERTY DAMAGE.

This document and other information from The Company, its subsidiaries and authorized distributors provide product and/or system options for further investigation by users having technical expertise. It is important that you analyze all aspects of your application, including consequences of any failure and review the information concerning the product or systems in the current product catalog. Due to the variety of operating conditions and applications for these products or systems, the user, through its own analysis and testing, is solely responsible for making the final selection of the products and systems and assuring that all performance, safety and warning requirements of the application are met.

The products described herein, including without limitation, product features, specifications, designs, availability and pricing, are subject to change by The Company and its subsidiaries at any time without notice.

EXTRA COPIES OF THESE INSTRUCTIONS ARE AVAILABLE FOR INCLUSION IN EQUIPMENT / MAINTENANCE MANUALS THAT UTILIZE THESE PRODUCTS. CONTACT YOUR LOCAL REPRESENTATIVE.

Figure 1

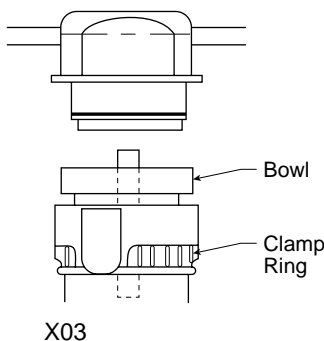

Figure 2

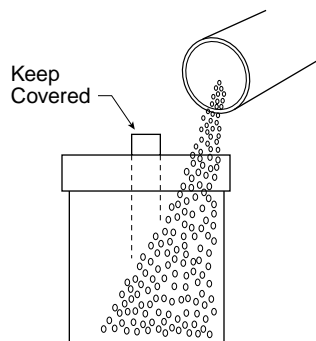
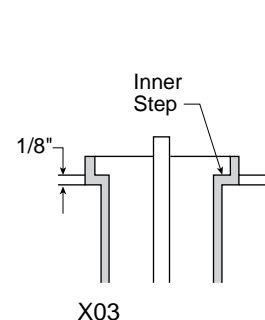

Figure 3



Replacement Parts List — TRANSPARENT BOWL Units with Bowl Guards

Description	Part No.	X03 Qty.
1 Cover	NNR	—
2 Screen Assembly	NNR	1
3 Bowl O-Ring	GRP-95-256	1
4 Tube Assembly w/screen	DRP-96-435	1
5 Transparent Bowl	GRP-95-871	1
6 Silica Gel (000) 4A Molecular Sieve (U00) 13x Molecular Sieve (X00) Environment Friendly (E00)	DRP-85-059 DRP-85-060 DRP-85-061 DRP-85-447	8 Bags / 7 lbs. 8 Bags / 7 lbs. 8 Bags / 7 lbs. 8 Bags / 7 lbs.
7 Bowl Guard	DRP-95-810	1
8 Clamp Ring	GRP-96-404	1

FLOW → (all units)

MODEL X03/X04 WITH TRANSPARENT BOWL

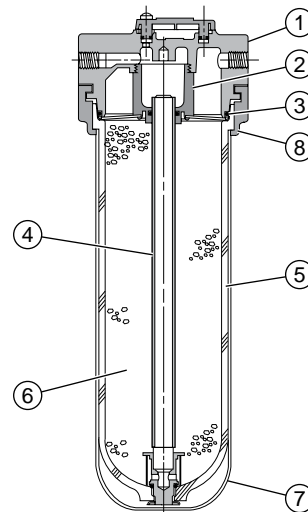
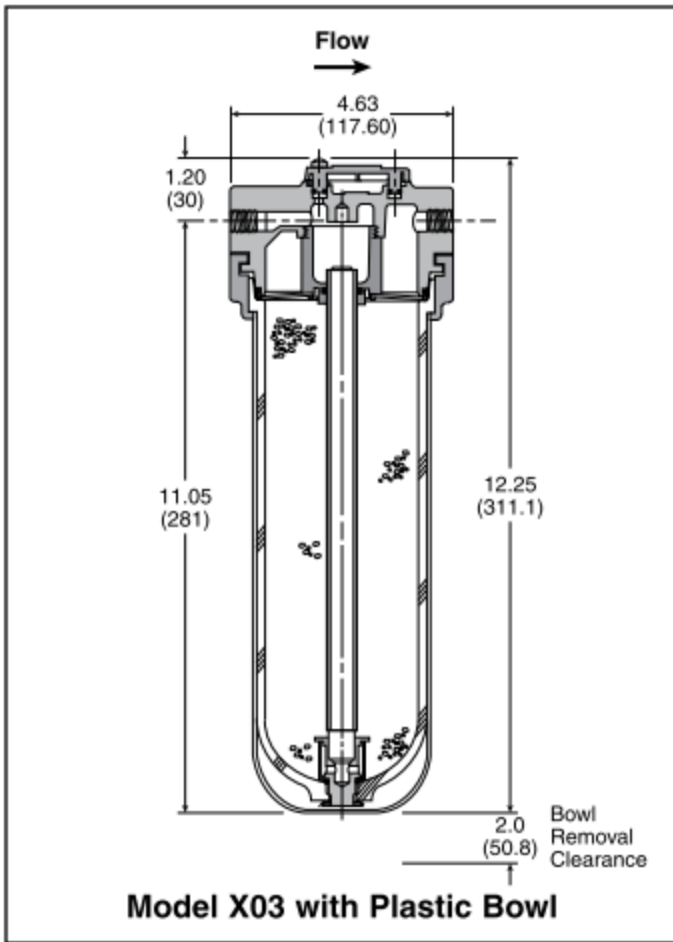

WILKERSON WARRANTY

Wilkerson products are warranted to be free from defects in material and workmanship, under proper use, installation, application and maintenance in accordance with Wilkerson's written recommendations and specification for a period of one year from the date of shipment from the factory (refrigerated dryers are warranted for 2 years). Wilkerson's obligation under this warranty is limited to, and the sole remedy for any such defect shall be, the repair or replacement (at Wilkerson's option) of unaltered products returned to Wilkerson and proven to have such defect, provided such defect is promptly reported to Wilkerson within said one-year period.

This is the only authorized Wilkerson Warranty and is in lieu of all other express or implied warranties or representations, including any implied warranties of merchantability or fitness, or of any other obligations on the part of Wilkerson.

Warranty claims must be submitted and shall be processed in accordance with Wilkerson's established warranty claim procedure. In no event will Wilkerson be liable for business interruptions, loss of profits, personal injury, costs of delay or for any other special, indirect, incidental or consequential losses, cost or damages.

WARNING: USE LIMITATIONS

Wilkerson's warranties are void, and Wilkerson assumes no responsibility for any resulting cost, loss, injury or any other damages whatsoever, with respect to any plastic bowl unit for which a bowl guard is standard equipment if the unit is placed in service without the bowl guard and, except as otherwise specified in writing by Wilkerson, with respect to any Wilkerson products which are used in other than compressed air service. Specific warnings with respect to these and other use limitations appear elsewhere in this catalog.

Wilkerson maintains a policy of ongoing product development and improvement. We therefore reserve the right to change dimensions specification and design without notice.

DO NOT PLACE PLASTIC BOWL UNIT IN SERVICE WITHOUT BOWL GUARD INSTALLED

Plastic bowl units are sold only with bowl guards with the exception to miniature units (C04, F00, L00, and M00). To minimize the danger of flying fragments in the event of plastic bowl failure, the bowl guards should not be removed. If the unit is in service without the bowl guard installed, manufacturer's warranties are void, and the manufacturer assumes no responsibility for any resulting loss.

If the unit has been in service and does not have a bowl guard, order one and install before placing back in service.

CAUTION

Certain compressor oils, chemicals, household cleaners, solvents, paints and fumes will attack plastic bowls and can cause bowl failure. Do not use near these materials. When bowl becomes dirty replace bowl or wipe only with a clean, dry cloth. Reinstall bowl guard or buy and install a bowl guard. Immediately replace any crazed, cracked, damaged or deteriorated plastic bowl with a bowl or a new plastic bowl and bowl guard.

CAUTION

Except as otherwise specified by the manufacturer, this product is specifically designed for compressed air service, and use with any other fluid (liquid or gas) is a misapplication. For example, use with or injection of certain hazardous liquids or gases in the system (such as alcohol or liquid petroleum gas) could be harmful to the unit or result in a combustible condition or hazardous external leakage. Before using with fluids other than air, or for non-industrial applications, or for life support systems, consult Wilkerson Corporation for written approval.

SOME OF THE MATERIALS THAT WILL ATTACK POLYCARBONATE PLASTIC BOWLS.

Acetaldehyde	Chlorobenzene	Methylene chloride
Acetic acid (conc.)	Chloroform	Methylene salicylate
Acetone	Cresol	Milk of lime (CaOH)
Acrylonitrile	Cyclohexanol	Nitric acid (conc.)
Ammonia	Cyclohexanone	Nitrobenzene
Ammonium fluoride	Cyclohexene	Nitrocellulose lacquer
Ammonium hydroxide	Dimethyl formamide	Phenol
Ammonium sulfide	Diozane	Phosphorous hydroxy chloride
Anaerobic adhesives and sealants	Ethane tetrachloride	Phosphorous trichloride
Antifreeze	Ethyl acetate	Propionic acid
Benzene	Ethyl ether	Pyridine
Benzene acid	Ethylamine	Sodium hydroxide
Benzyl alcohol	Ethylene chlorohydrin	Sodium sulfide
Brake fluids	Ethylene dichloride	Styrene
Bromobenzene	Ethylene glycol	Sulfuric acid (conc.)
Butyric acid	Formic acid (conc.)	Sulphural chloride
Carbolic acid	Freon (refrig. & Propell.)	Tetrahydronaphthalene
Carbon disulfide	Gasoline (high aromatic)	Tiophene
Carbon tetrachloride	Hydrazine	Toluene
Caustic potash solution	Hydrochloric acid (conc.)	Turpentine
Caustic soda solution	Lacquer thinner	Xylene
	Methyl alcohol	Perchlorethylene & Others

TRADE NAMES OF SOME COMPRESSOR OILS, RUBBER COMPOUNDS AND OTHER MATERIALS THAT WILL ATTACK POLYCARBONATE PLASTIC BOWLS.

Atlas "Perma-Guard"	National Compound #N11
Buna N	"Nylock" VC-3
Cellulube #150 and #220	Parco #1306 Neoprene
Crylex #5 cement	*Permabond 910
*Eastman 910	Petron PD287
Garlock #98403 (polyurethane)	Prestone
Haskel #568-023	Pydraul AC
Hilgard Co.'s hil phene	Sears Regular Motor Oil
Houghton & Co. oil #1120, #1130 & #1055	Sinclair oil "Lily White"
Houtosafe 1000	Stauffer Chemical FYRQUEL #150
Kano Kroil	Stillman #SR 269-75 (polyurethane)
Keystone penetrating oil #2	Stillman #SR 513-70 (neoprene)
*Loctite 271	Tannergas
*Loctite 290	Telar
*Loctite 601	Tenneco anderol #495 & #500 oils
*Loctite Teflon-Sealant	Titon
Marvel Mystery Oil	*Vibra-tite
Minn. Rubber 366Y	Zerex

*When in raw liquid form.

We cannot possibly list all harmful substances, so check with Mobay or the General Electric office for further information on polycarbonate plastic.

The trade names "EconOmist" and "Flow-Guide" are registered at the United States Patent Office. "Auto-Fill", "Dial-Air", "Flex-Drain", "Mainliner" and "Whirl-Flo" are trade names of the Wilkerson Corporation.

WILKERSON PRODUCTS ARE PROTECTED BY THE FOLLOWING U.S. PATENT AND PATENTS IN OTHER COUNTRIES, ADDITIONAL PATENTS ARE PENDING.

3,631,878	3,667,493	3,762,224	4,215,790
4,215,790	3,793,803	4,718,245	3,793,803
3,858,403	D-292-310	D-229-629	4,215,790
4,289,335	4,352,511	4,559,065	4,631,073
4,689,969	4,696,320	3,889,484	3,945,465
4,631,073	D-234-848		

WILKERSON®

Customer/Technical Service
Pneumatic Division
Richland, MI 49083

Tel: (269) 629-2550
Fax: (269) 629-2475



OIL-LESS COMPRESSOR INSTRUCTION SHEETS

NOTE

This compressor is intended for installation indoors for use on dry sprinkler systems in accordance with the Standard for Installation of Sprinkler Systems, NFPA 13 and the National Electrical Code, NFPA 70. The compressor should be sized to restore and maintain the air pressure in the sprinkler system in accordance with the requirements in NFPA 13.

DANGER

This compressor is not equipped and should NOT be used "as is" to supply breathing quality air.

WARNING

Motors, electrical equipment and controls can cause electrical arcs that will ignite a flammable gas or vapor. Never operate or repair in or near a flammable gas or vapor. Never store flammable liquids or gases near the compressor.

WARNING

These compressors are suitable for pumping only atmospheric air. As defined in Compressed Gas Association Pamphlet G-7, page 3, atmospheric air is a mixture of elements and compounds where nitrogen and oxygen comprise more than 99% with all other trace gases comprising less than 1%. **DO NOT USE THIS COMPRESSOR IN CONTAMINATED ENVIRONMENTS OR FOR PUMPING MIXTURES OTHER THAN ATMOSPHERIC AIR**

WARNING

Compressed air contains liquid water and is saturated with water vapor, which can freeze. Do not connect compressor outlet to freezer rooms or systems exposed to temperatures below freezing. If system connects to a freezer room or area exposed to freezing temperatures, a Dry Air Pac™ should be used.

Receiving

Your compressor is inspected at the factory and packaged to protect against shipping damage. When the compressor is unpacked, inspect for damage or missing parts. All claims should be settled directly with the freight company.

WARNING: Do not operate this compressor if damaged during shipment, handling, or use. Damage may result in bursting and cause injury or property damage.

Location

NOTE: Do not connect compressor intake to freezer room. – CALL 1-800-345-8207.

Locate the compressor in a clean, well-ventilated area where the air is relatively cool, clean, and dry. A 110°F (35 C) maximum and 40°F (4.5 C) minimum temperature for surrounding and inlet air are recommended. Provide at least 12 to 18 inches from any wall or other obstruction that will interfere with airflow through the motor's fan built into the motor. Blocking airflow through the fan may cause the compressor to over heat. Do not place the compressor in an area of excessive heat, such as near a boiler.

Mounting

Riser mounted compressors may be mounted to a firm level floor, wall or system riser. A mounting bracket

and straps are provided. Tank mounted compressors should be bolted to the floor using the bolt holes provided in the tank legs. Always shim the unit level before bolting it to the floor. Vibration isolators (P/N KVP4X4) are recommended. When using isolator pads, do not draw bolts tight. Allow the pad to absorb vibrations. When isolators are used, a flexible hose (P/N P1202MP) should be installed between the compressor and service piping.

Lubrication

NOTE: This compressor is designed for non-lubricated service. Bearings are permanently lubricated. Do not lubricate any part of the compressor or motor.

Piping (reference "Installation Instructions" drawings)**WARNING**

Compressed air contains liquid water and is saturated with water vapor, which can freeze. Do not connect compressor outlet to freezer rooms or systems exposed to temperatures below freezing. If system connects to a freezer room or area exposed to freezing temperatures, a Dry Air Pac™ should be used.

Piping between the compressor, accessory items and the sprinkler system should be at least ½" internal

For Assistance Please Call 1-800 345-8207

Please keep these instructions for future reference.

GENERAL AIR PRODUCTS, INC.

diameter to minimize pressure drop from the compressor to system. Larger pipe size may be required by code and may be substituted with no adverse effects. Smaller line size must not be used and will restrict the compressor flow, lowering capacity and causing the compressor/motor to work harder, which shortens compressor/motor life. All piping connected to the compressor must be fully supported and not transfer any loads to the compressor.

All oil-less compressors include a relief valve. For riser mounted models, the relief valve is installed on the compressor outlet. For tank mounted models, an ASME Code relief valve is mounted on the compressor's tank. This valve will open at a preset value above the pressure switch setting to prevent excess tank pressure in the event of switch failure.

WARNING: Do not attempt to change the safety relief valve setting.

The compressor outlet piping should contain an accessible drain. As a minimum a manual drain may be used, but an automatic drain is recommended to remove excess water.

NOTE: Accumulation of condensed water in a system causes corrosion of components and reduces system capacity.

NOTICE: Warranty is void if a separate check valve is not installed to prevent water back flow.

Wiring (reference "Wiring Instructions" drawings)

WARNING

Have a qualified electrician wire the compressor to ensure that the supply line has the same characteristics (voltage, frequency and phasing) as the motor. Wiring must comply with all local and national codes.

CAUTION

Inadequate wiring size can cause insufficient voltage at the compressor during start-up. Overheating and damage to the motor and controls may result

The supply wire must be of adequate size and no other equipment should be connected to the same line. The table below lists the recommended wire size for each model, based on a 100' run. Consult factory for longer runs.

The motors supplied are multiple voltage motors. A label on the pressure switch cover indicates the voltage the motor is pre-wired for. If the supply voltage, on site, is different from the voltage indicated on this label, change the internal motor voltage connections to match the supply voltage. To change internal voltage connections, remove the cover plate located on the rear or side of the motor and reconnect the wire leads as shown on the motor's wiring diagram.

On all three phase and ½ Hp and ¾ Hp single phase models, an arrow on the motor indicates the direction of rotation of the compressor. If the compressor rotates in the opposite direction, reverse the rotation of the motor. On single phase units, reverse motor rotation by interchanging the red and black motor leads. Interchanging any two incoming supply wires reverses rotation of three phase motors.

NOTICE: Single-phase oil-less compressors can not be operated at 208V. Operating the compressor at 208V voids the warranty.

NOTICE: Single-phase motors include internal thermal overload protection, which has an automatic reset device.

WARNING: Disconnect electrical power before servicing to disable reset devices. Thermal protection can automatically start the motor when the protector resets.

On single phase models, the motor is pre-wired to the pressure switch provided, which controls starting (cut

GENERAL AIR PRODUCTS, INC.

in pressure) and stopping (cut out pressure) of the motor. The pressure switch is factory set. Standard models switch is set at 27 psig cut in and 40 psig cut out. Low pressure models (“-LP”) switch is set at 13 psig cut in and 18 psig cut out. Consult General Air Products before adjusting the pressure switch.

NOTE: Failure to use the pressure switch may result in overpressure of the compressor or other components in the system. Overpressure of the compressor may result in blown head gaskets or other damage.

Maintenance Instructions

WARNING
DISCONNECT, TAG AND LOCK OUT POWER SOURCE THEN RELEASE ALL PRESSURE FROM THE SYSTEM BEFORE ATTEMPTING TO INSTALL, SERVICE, RELOCATE OR PERFORM ANY SERVICE.

The following instructions are based on NORMAL operation. If the compressor is in an excessively dusty area, increase frequency of maintenance checks.

WEEKLY

- Drain condensate from receiver and traps.
- Check for unusual noise or vibration.
- Clean air filters. – **NOTE: Do not clean filters with petroleum based products.**
- Clean all external parts of the compressor and motor.

MONTHLY

- Manually test safety relief valve.
- Inspect air system for leaks and tighten nuts and cap screws as required.

QUARTERLY

- Change filters.

Limited Warranty

General Air Products, Inc. warrants its products to be free of defects in material and workmanship under normal use and service for 12 months from date of purchase. Our warranty applies only when such defective parts are returned to us, or our Authorized Service Depot, transportation prepaid, and subject to our inspection and approval. Liability is limited to repair or replacement of material found defective, free of charge, FOB our plant. Unauthorized repairs or replacements will not be subject to factory warranty. This warranty is in lieu of all other warranties, expressed or implied.

General Notes

- 1) Warranty can be voided if modifications or adjustments are made without consultation and approval; from factory personnel.
- 2) If there are any questions regarding installation or operation of this compressor, please call the 800 number listed below.

 **GENERAL AIR PRODUCTS, INC.**

For Assistance Please Call 1-800 345-8207
Please keep these instructions for future reference.

OILLESSINST
REV 080906

✿GENERAL AIR PRODUCTS, INC.

Trouble Shooting Guide

Symptom	Possible Cause(s)	Corrective Action
Motor hums and runs slowly or not at all	<ol style="list-style-type: none"> 1. Low voltage or no voltage 2. Shorted or open motor winding 3. Defective check valve 4. Defective pressure switch – contacts will not close 	<ol style="list-style-type: none"> 1. Check voltage during attempt to start. Voltage must be within +/-10% of nominal voltage to start motor. Increase wire size if necessary to lower voltage drop. 2. Replace motor 3. Replace check valve 4. Repair or replace pressure switch
Reset mechanism cuts out repeatedly or fuses blow repeatedly	<ol style="list-style-type: none"> 1. Insufficient voltage to motor 2. Pressure switch set too high 3. Wrong fuse size 4. Piping too restrictive 5. Defective motor 	<ol style="list-style-type: none"> 1. Check voltage during attempt to start. Voltage must be within +/-10% of nominal voltage to start motor. Increase wire size if necessary to lower voltage drop. 2. Consult factory, adjust or replace 3. Be sure fuses and heaters are rated properly 4. Add receiver vessel or increase pipe volume after compressor. 5. Replace motor
Unit short cycles repeatedly	<ol style="list-style-type: none"> 1. Piping too restrictive 2. Leak in line before system check valve 	<ol style="list-style-type: none"> 1. Add receiver vessel or increase pipe volume after compressor. 2. Repair leaks(s)
Compressor Overheating	<ol style="list-style-type: none"> 1. Dirty intake filter 2. Wrong motor rotation 3. Air flow to fan on flywheel blocked 	<ol style="list-style-type: none"> 1. Clean intake filter 2. Correct rotation 3. Clear air flow to fan or relocate unit
Excessive noise in operation	<ol style="list-style-type: none"> 1. Damaged bearings 2. Worn piston rings or skirts 3. Broken valves 4. Loose blower wheel 5. Damaged Blower baffle 	<ol style="list-style-type: none"> 1. Contact General Air Products, Inc. Service Department. 1-(800)345-8207
System pressure builds slowly	<ol style="list-style-type: none"> 1. Compressor sized incorrectly 2. Leaks or restrictions in piping 3. Dirty intake filter 4. Blown head gasket 	<ol style="list-style-type: none"> 1. Check system size and compressor sizing 2. Correct leaks and remove restrictions 3. Clean intake filter 4. Replace head gasket

For Assistance Please Call 1-800 345-8207
Please keep these instructions for future reference.

OIL-LESS COMPRESSOR SINGLE PHASE WIRING INSTRUCTIONS

NOTE: MOST MOTORS ARE MULTIPLE VOLTAGE. CHECK NAMEPLATE AND VERIFY CORRECT INTERNAL CONNECTIONS FOR VOLTAGE BEING SUPPLIED TO UNIT.

FEEDER WIRE SIZE MUST BE CAPABLE OF CARRYING CURRENT LOAD OF COMPRESSOR AT MAXIMUM PRESSURE.

LINE

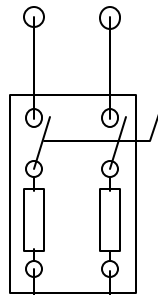

FUSED
DISCONNECT

PRESSURE
SWITCH

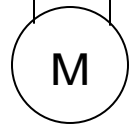
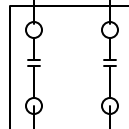

FIG 1

FIG 1

SINGLE PHASE
BUILT IN OVERLOAD
PROTECTION. (NOT
TO EXCEED 3/4 HP).

FOR 115V ELIMINATE
FUSE IN GROUND LEG.

PRESSURE SWITCH HP
RATING MUST NOT BE
EXCEEDED.

OTHER WIRING VARIATIONS
POSSIBLE DEPENDING ON
LOCAL CODES.

(THIS SURFACE DELIBERATELY LEFT BLANK)

(THIS SURFACE DELIBERATELY LEFT BLANK)



UNITED Fire Systems

Division of UNITED Fire Protection Corporation

1 Mark Road

Kenilworth, NJ USA 07033

908-688-0300

www.unitedfiresystems.net